



## Seiko H601A Movement Parts (1)

Compiled by EmmyWatch - <https://www.emmywatch.com>

# PARTS CATALOGUE/ TECHNICAL GUIDE

## Cal. H601A

### [SPECIFICATIONS]

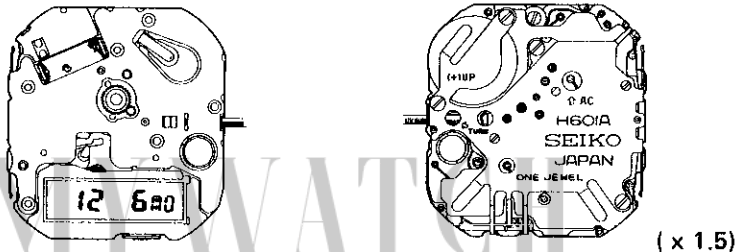
Cal. No.		H601A	
Item			
Movement			
Movement size	Outside diameter	24.5 mm between 6 o'clock and 12 o'clock sides 23.0 mm between 3 o'clock and 9 o'clock sides	
	Casing diameter	—	
	Height	2.5 mm	
		Analogue section	Digital section
Time indication		3 hands	Nematic Liquid Crystal, FEM (Field Effect Mode)
Driving system		Step motor (Load compensated driving pulse type)	Multiplex driving system
Additional mechanism		<ul style="list-style-type: none"> <li>• Electronic circuit reset switch</li> <li>• Train wheel setting device</li> </ul>	<ul style="list-style-type: none"> <li>• Hourly time signal</li> <li>• Alarm test system</li> <li>• Illuminating light</li> </ul>
Loss/gain		Monthly rate at normal temperature range: less than 15 seconds	
Regulation system		Trimmer condenser	
Measuring gate by quartz tester		Any gate can be used (Use the analogue section to measure accuracy.)	
Battery		SEIKO SR920W, Maxell SR920W Battery life is approximately 2 years. Voltage: 1.55V	
Jewels		1 jewel	

Disassembling procedures Figs. : ① → ③③

Reassembling procedures Figs. : ③③ → ①

**Lubricating: Types of oil**

● Moebius A

○ SEIKO Watch Oil S-6

**Oil quantity**

○ Normal quantity

○ Extremely small

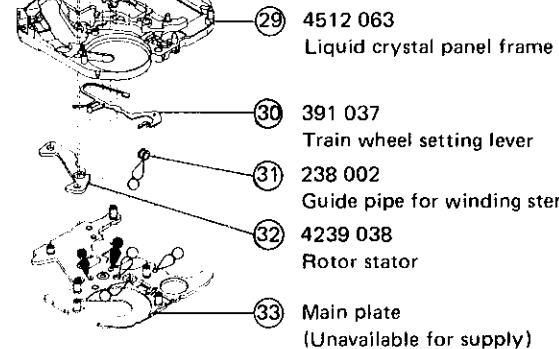
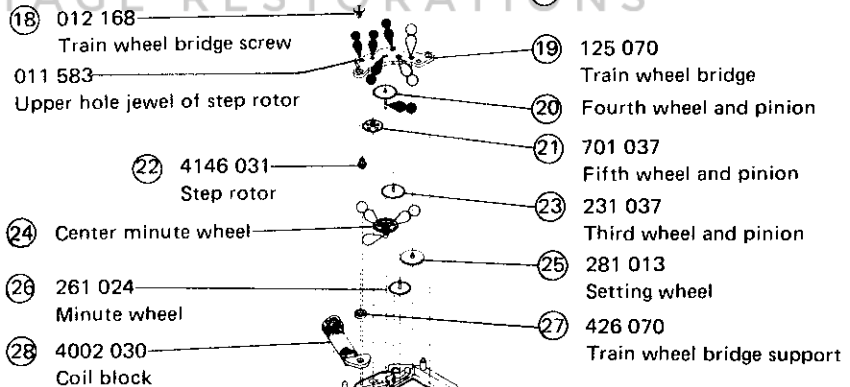
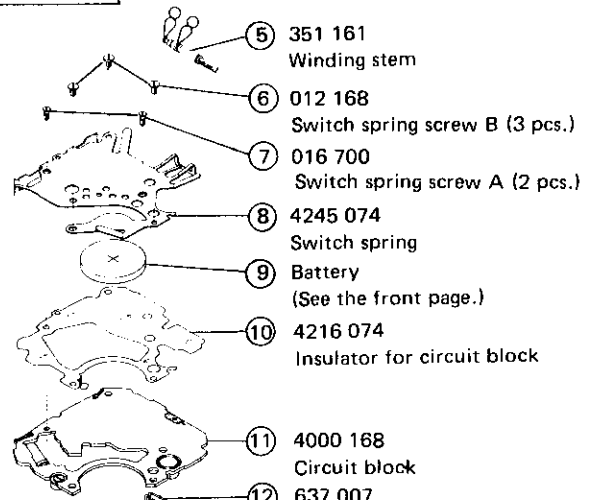
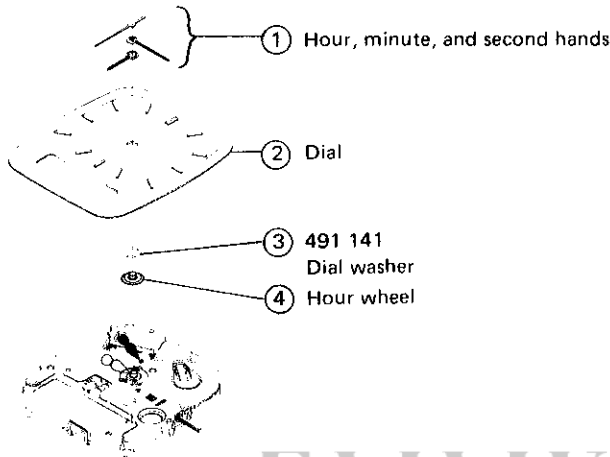

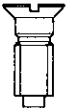
	012 168 Switch spring screw B (3 pcs.) Train wheel bridge screw (1 pc.)
	016 700 Switch spring screw A (2 pcs.)

○ → Please see the remarks on the following pages.

**Remarks:**

● **Other parts:**

Bulb 4530 017

The bulb which is soldered to the circuit block is available for supply.



Piezoelectric element 4589 013

The piezoelectric element which is adhered to the inside of the case back is available for supply.

**Tubes**

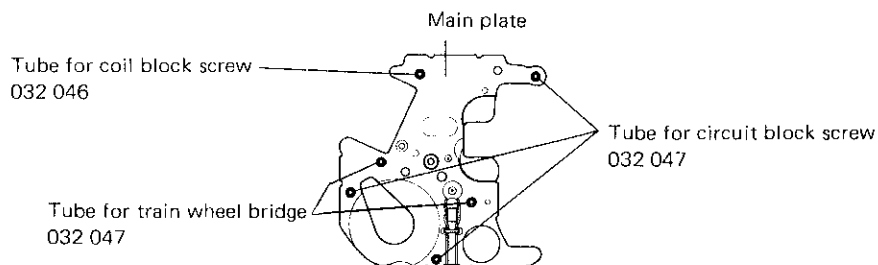







④ Hour wheel

⑳ Fourth wheel and pinion

㉔ Center minute wheel

**Combination:**

	Hour wheel	Fourth wheel and pinion	Center minute wheel
a	 271 189	 241 089	 270 072
b	 271 190	 241 116	 270 119

⑤ Winding stem 351 161

⑰ Liquid crystal panel 4510 038 (silver), 4510 040 (gold)

The types of these parts depend on the design of each model.  
Refer to "SEIKO Casing Parts Catalogue" to choose corresponding parts.

- The explanation here is only for the particular points of Cal. H601A.
- For the repairing, checking and measuring procedures, refer to the "TECHNICAL GUIDE, GENERAL INSTRUCTION".

## I. STRUCTURE OF THE CIRCUIT BLOCK

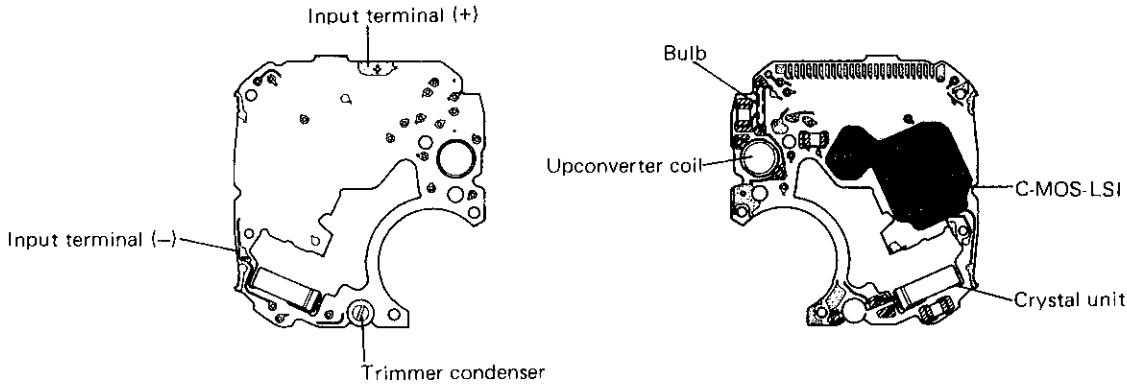

## II. RELATIONSHIP BETWEEN THE SEGMENT (LIQUID CRYSTAL PANEL ELECTRODE) AND THE C-MOS-LSI OUTPUT TERMINAL

- Designation of the segment

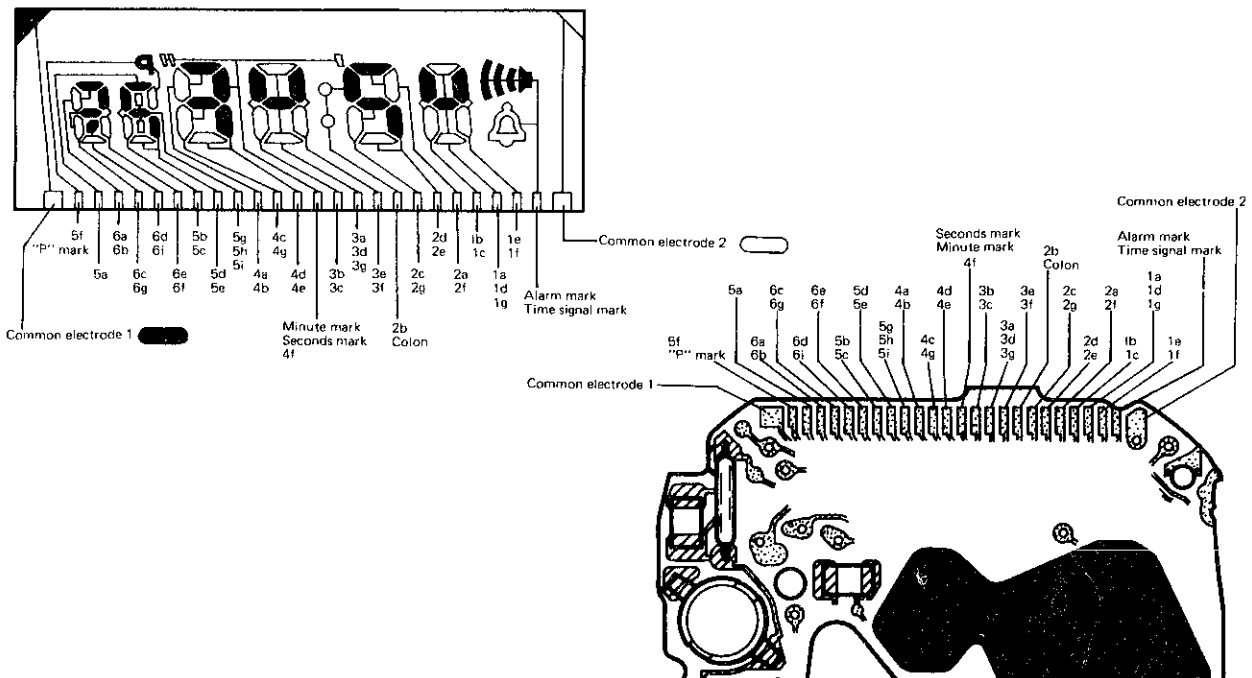
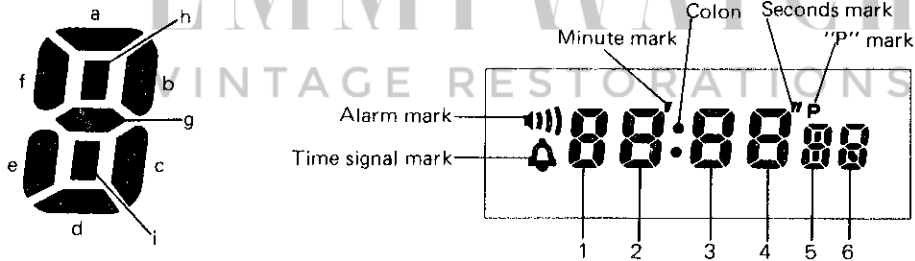

### III. REMARKS ON DISASSEMBLING AND REASSEMBLING

Use the universal movement holder for disassembling and reassembling.

• **Remarks on installing the battery**

After installing the battery, short-circuit AC terminal of the circuit block and the switch spring with tweezers.

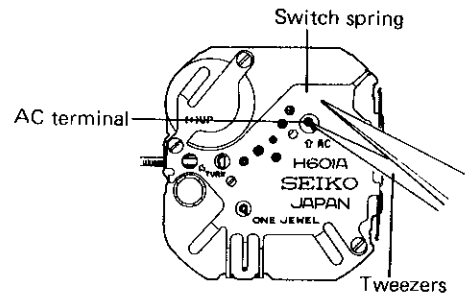

① Hands

When installing the hands, place the movement directly on a flat metal plate or the like.

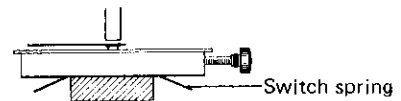

⑤ Winding stem

• **How to remove**

Insert the tip of a screwdriver into the hole marked by "TURN ⇒", then turn the screwdriver about 90° in either direction, and slowly pull out the winding stem.

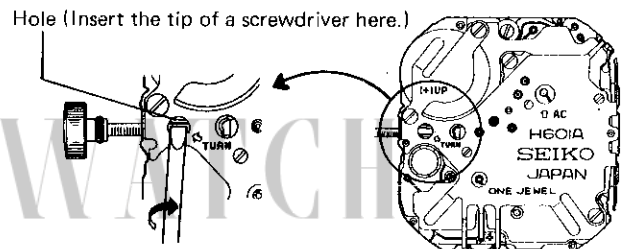

EMMY WATCH  
VINTAGE RESTORATIONS

⑧ Switch spring

⑨ Battery

• **How to install**

- 1) Set the switch spring, and tighten both of the two switch spring screws A (Fig. 1).
- 2) Have the hook portion (2 places) of the switch spring catch the liquid crystal panel frame (Fig. 2 & 3).
- 3) Lift up the battery clamp portion by finger and insert the battery sideways (Fig. 4).
- 4) Tighten the three switch spring screws B (Fig. 1).

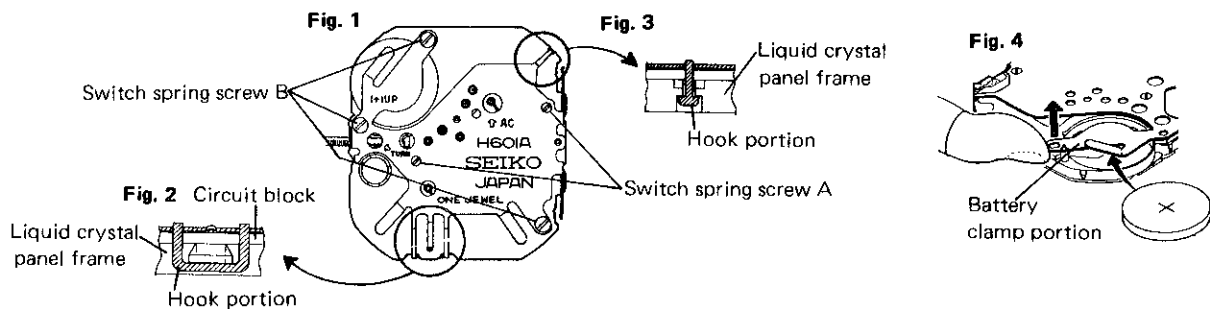

⑬ Buzzer lead terminal

• **Setting position**

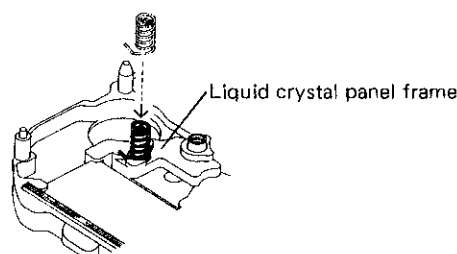

- ⑮ Reflecting mirror
- ⑯ Liquid crystal panel

• **How to install**

Slide the liquid crystal panel in the direction indicated by the arrow to set it in position to the liquid crystal panel frame (Fig. 1).

Then, slide the reflecting mirror in the direction indicated by the arrow until the other end of the reflecting mirror is set inside of the location guide pin (Fig. 2 & 3).

Fig. 1

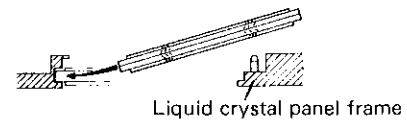

Fig. 2

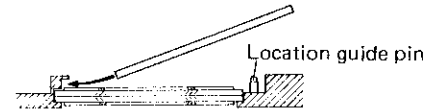
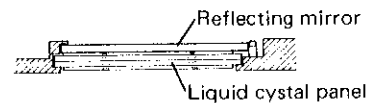
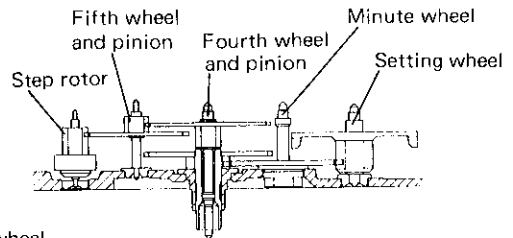
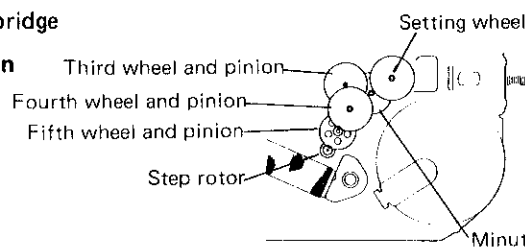

Fig. 3



- ⑰ Train wheel bridge

• **Setting position**



- ⑱ Train wheel setting lever

• **Remarks on installing**

After reassembling ⑳ Main plate through ⑥ Switch spring screw B, turn over the movement, and hook the end of the train wheel setting lever to the liquid crystal panel frame as shown in the illustration on the right.

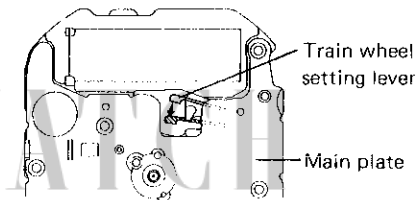

## IV. VALUE CHECKING

- Coil block resistance  
2.6KΩ ~ 3.2KΩ
- Upconverter coil resistance  
120Ω ~ 180Ω
- Current consumption  
For the whole of the movement : less than 2.0μA  
For the circuit block alone : less than 1.2μA

**Remarks:**

- After the wire of tester with a current supplier is arranged, short-circuit AC terminal of the circuit block and the switch spring with tweezers.  
(Refer to "Remarks on installing the battery" on page 5.)

Otherwise, the digital display will become disordered, and as a result current consumption cannot be measured correctly.

- When the current consumption exceeds the standard value for the whole of the movement but is less than the standard value for the circuit block alone, overhaul and clean the movement parts and then measure current consumption for the whole of the movement again. The driving pulse generated to compensate a heavy load that may apply on the gear train, etc. is considered to cause excessive current consumption for the whole of the movement.