



Seiko 7813A Movement Parts (1)

Compiled by EmmyWatch - <https://www.emmywatch.com>

SEIKO

QUARTZ

Cal. 7813A

EMMYWATCH
VINTAGE RESTORATIONS

PARTS LIST

Cal. 7813A

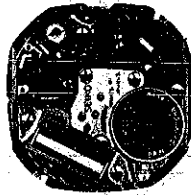

122 781



131 781



221 781



☆ 225 784



231 781



☆ 241 784



261 781



☆ 271 784



281 589



282 782



354 781



383 780



384 781



386 782



390 780



391 781



☆ 397 780



399 780



☆ 470 785



701 781



☆ 801 785



802 781



808 781



810 781



868 781

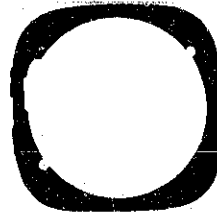

☆ 884 692



962 781



963 781



981 781



4001 781

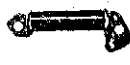

4002 782



4146 781



4216 781



4242 780



4259 772



☆ SEIKO SB-AP



022 426



022 468



022 491



022 754



022 764



027 492

2/1

Cal. 7813A

Characteristics

Casing diameter : ϕ 23.3 mm
 Maximum height : 3.5 mm without battery
 Jewels : 5 j
 Frequency of quartz crystal oscillator : 32,768 Hz (Hz=Hertz Cycles per second)
 Driving system : Step motor system (2 poles)
 Regulation system : Trimmer condenser
 Second setting device
 Calendar (day & date)
 Instant setting device for day & date calendar
 Bilingual change-over system for day of the week
 Battery life indicator : Second hand moves in two-second interval

PART NO.	PART NAME	PART NO.	PART NAME
122 781	Center wheel bridge	022 491	Date jumper screw A
131 781	Third wheel bridge	022 491	Day finger screw
221 781	Center wheel & pinion	022 754	Date jumper screw B
☆225 784	Cannon pinion (2.47 mm)	022 754	Date dial guard screw
☆225 788	Cannon pinion (2.72 mm)	022 764	Dial screw
231 781	Third wheel & pinion	027 492	Pin for plus terminal of battery connection
☆241 784	Fourth wheel & pinion (5.16 mm)	011 324	Upper hole jewel for fifth wheel
☆241 788	Fourth wheel & pinion (5.41 mm)	011 324	Lower hole jewel for fifth wheel
261 781	Minute wheel	011 404	Upper hole jewel for fourth wheel
☆271 784	Hour wheel (1.88 mm)	011 537	Upper hole jewel for step rotor
☆271 788	Hour wheel (2.13 mm)	011 537	Lower hole jewel for step rotor
281 589	Setting wheel	☆SEIKO SB-AP	Silver oxide battery
282 782	Clutch wheel	☆Maxell SR926SW	
354 781	Winding stem		
383 780	Setting lever		
384 781	Yoke (Clutch lever)		
386 782	Setting lever spring		
390 780	Setting lever axle		
391 781	Second-setting lever		
☆397 780	Lever for unlocking stem		
☆397 781			
☆397 782			
399 780	Casing clamp		
☆470 785	Day star with dial disk		
701 781	Fifth wheel & pinion		
☆801 785	Date dial		
802 781	Date driving wheel		
808 781	Date dial guard		
810 781	Date jumper		
868 781	Day finger		
☆884 692	Holding ring for dial		
962 781	Intermediate wheel for calendar correction		
963 781	Snap for day star with dial disk		
981 781	Day-date corrector wheel rocker		
4001 781	Circuit block		
4002 782	Coil block		
4146 781	Step rotor		
4216 781	Insulator for battery connection		
4242 780	Plus terminal of battery connection		
4259 772	Anti-magnetic shield plate		
022 426	Casing clamp screw		
022 468	Center wheel bridge screw		
022 468	Third wheel bridge screw		
022 468	Anti-magnetic shield plate screw		
022 468	Circuit block screw		
022 491	Setting lever spring screw		





☆⇨ Please see remarks on the reverse page.
 Part numbers in light letters are not shown in photos.

Cal. 7813A

Remarks :

Cannon pinion, Fourth wheel & pinion, Hour wheel

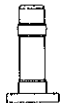
There are two different types as specified below.
Combination:

Type	Cannon pinion	Fourth wheel & pinion	Hour wheel
	 ☆225 784	 ☆241 784	 ☆271 784
	 ☆225 788	 ☆241 788	 ☆271 788

Type a : Used for the dial which does not have the rimmed calendar frame.
Type b : Used for the dial which has the rimmed calendar frame.

Lever for unlocking stem

☆397 780 } There are three types of lever for unlocking stem.
 ☆397 781 }
 ☆397 782 } The size of a lever for unlocking stem is determined based on the design of cases.



If the combination of the lever for unlocking stem and case is unknown, check the case number and refer to the "SEIKO Quartz Casing Parts List" to choose an appropriate lever for unlocking stem.

Day star with dial disk

☆470 785(English ↔ Spanish, black figures on white background).....Used when both the crown and the calendar frame are located at 3 o'clock position.

If any other type of day star with dial disk is required, specify the number printed on the disk.

Date dial

☆801 785(Black figures on white background).....Used when both crown and the calendar frame are located at 3 o'clock position.

If any other type of date dial is required, specify ① Cal. No. ② the crown position ③ the calendar frame position and ④ the dial No.

Holding ring for dial

☆884 692.....The type of holding ring for dial is determined based on the design of cases and dials. Check the case number and refer to "SEIKO Quartz Casing Parts List" to choose a corresponding holding ring for dial.

Battery

☆SEIKO SB-AP } The applied battery for this calibre might be added the substitutive in the future.
 ☆Maxell SR926SW } In that case, please refer to separate "BATTERIES FOR SEIKO QUARTZ WATCHES".

TECHNICAL GUIDE

SEIKO

QUARTZ

CAL.7813A

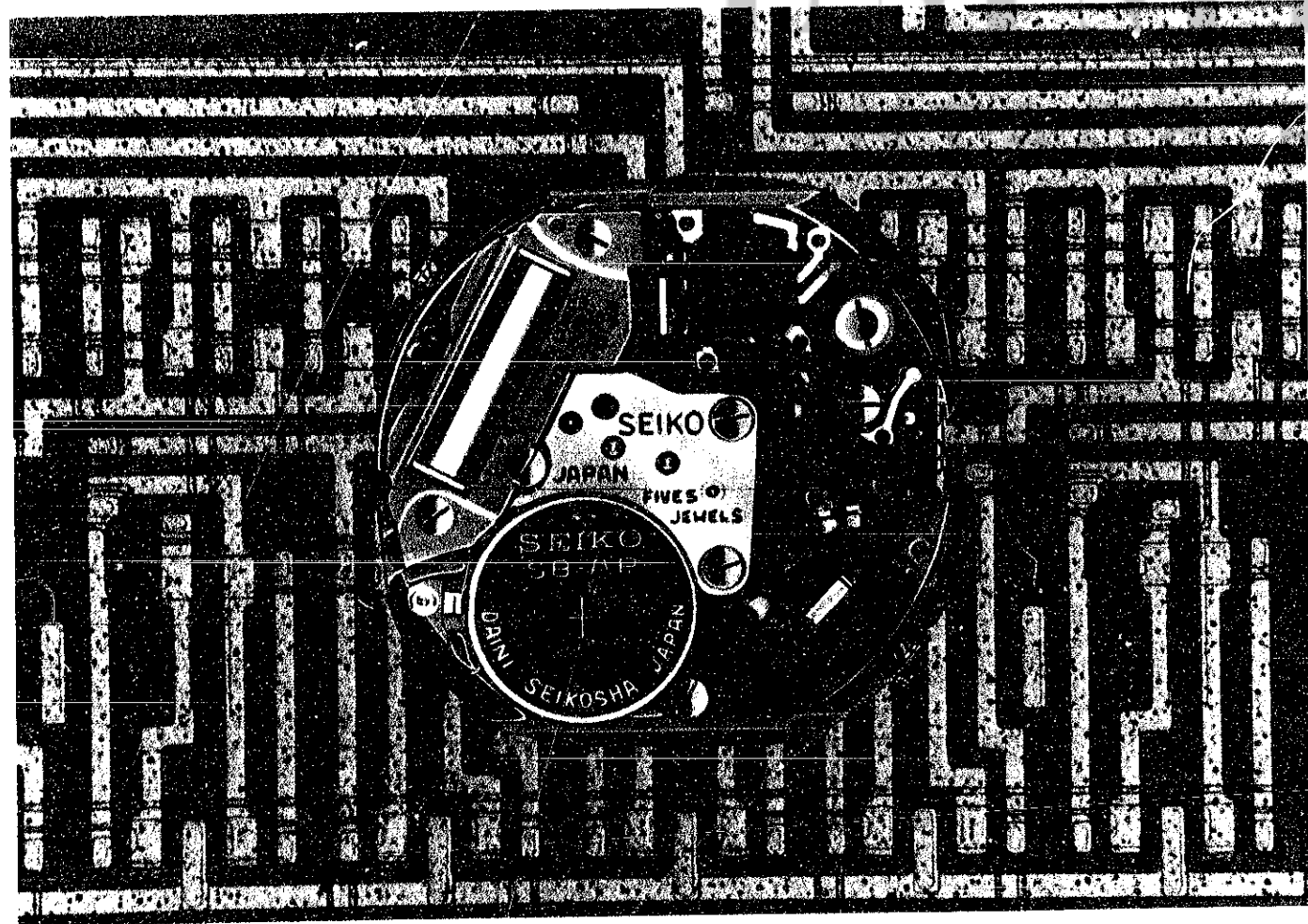

CONTENTS

I. SPECIFICATIONS AND FEATURES	2
1. Specifications	2
2. Features	2
II. FUNCTIONING	3
1. Movement structure	3
2. Outline of functioning	4
3. Functioning of electronic circuit block	4
4. Functioning of mechanical portion	6
III. HOW TO SET THE TIME AND CALENDAR	8
1. Resetting time	8
2. Resetting calendar	8
IV. CASE CONSTRUCTION	9
1. Case construction	9
2. Remarks for handling the case	10
3. Battery replacement	10
V. AFTER-SALE SERVICING INSTRUMENTS AND MATERIALS	11
VI. DISASSEMBLING, REASSEMBLING, LUBRICATING AND CLEANING	12
1. Disassembling, Reassembling and Lubricating	12
2. Cleaning	18

VII. CHECKING AND ADJUSTMENT	19
1. Guide table for checking and adjustment	19
2. Procedures for checking and adjustment	20
A: Check output signal	20
B: Check battery voltage	20
• How to check battery electrolyte leakage and repair	20
C: Check battery conductivity	22
D: Check circuit block conductivity	22
E: Check circuit block output terminal conductivity	22
F: Check coil block	24
G: Check output signal	24
H: Check second setting condition	26
I: Check reset condition	28
J: Check accuracy	28
K: Measuring current consumption	28

SEIKO Quartz Calibre 7813A

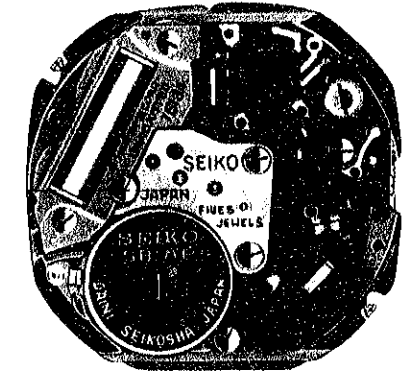
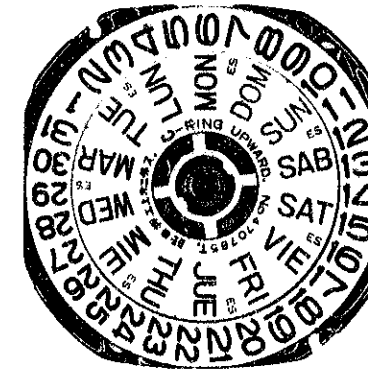

Movement

EMMYWATCH
VINTAGE RESTORATIONS

I. SPECIFICATIONS AND FEATURES

1. Specifications

Item	Calibre No. 7813A
Time indication	Hour, minute & second hands
Additional mechanism	<ul style="list-style-type: none"> ● Calendar (day & date) ● Bilingual changeover system for the day of the week ● Instant day and date setting ● Battery life indicator ● Second setting device (Stops at every second) ● Electronic circuit reset switch
Crystal oscillator	32,768 Hz (Hz = Hertz . . . Cycles per second)
Loss/gain	Loss/gain at normal temperature Monthly rate: less than 15 seconds (Annual rate: less than 3 minutes) Temperature compensation device
Casing diameter	φ23.3mm (φ21.2mm between 6 o'clock and 12 o'clock)
Height	3.5 mm
Operational temperature range	-10°C ~ +60°C (14°F ~ 140°F)
Driving system	Step motor system (2 poles)
Regulation system	Trimmer condenser
Battery power	Silver oxide battery SB-AP Battery life is approximately 2 years. Voltage 1.5 V
Jewels	5 jewels

2. Features

- (1) The ultra-thin movement of Cals. 78A and 7810A which is thinner than 3 mm in height is the result of SEIKO's endless effort to achieve even thinner watches than the Cal. 41 series which already has a reputation for its thinness. In addition, Cal. 7813A is a very practical watch for everyday use since it has been designed to show day & date.
- (2) Battery life indicator lets the second hand leap every 2 seconds when the battery life is coming to an end. This indicates the battery must be replaced. However, the watch keeps the correct time while the second hand leaps every 2 seconds.

II. FUNCTIONING

1. Movement structure

The movement consists of the circuit block, coil block, battery and the mechanical portion, of which the main components are a step motor and a gear train. Since each portion is a separate unit, easy checking and adjustment is possible.

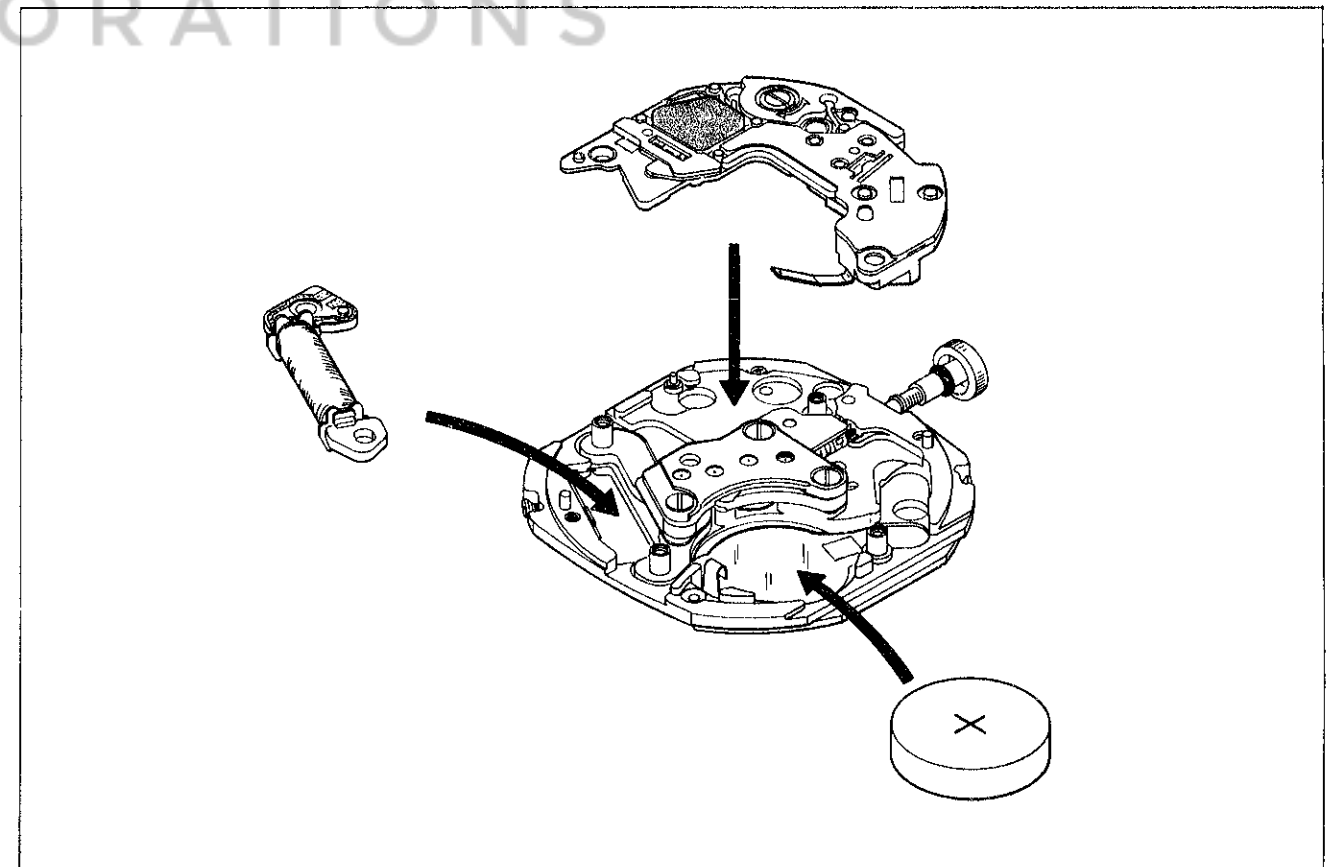
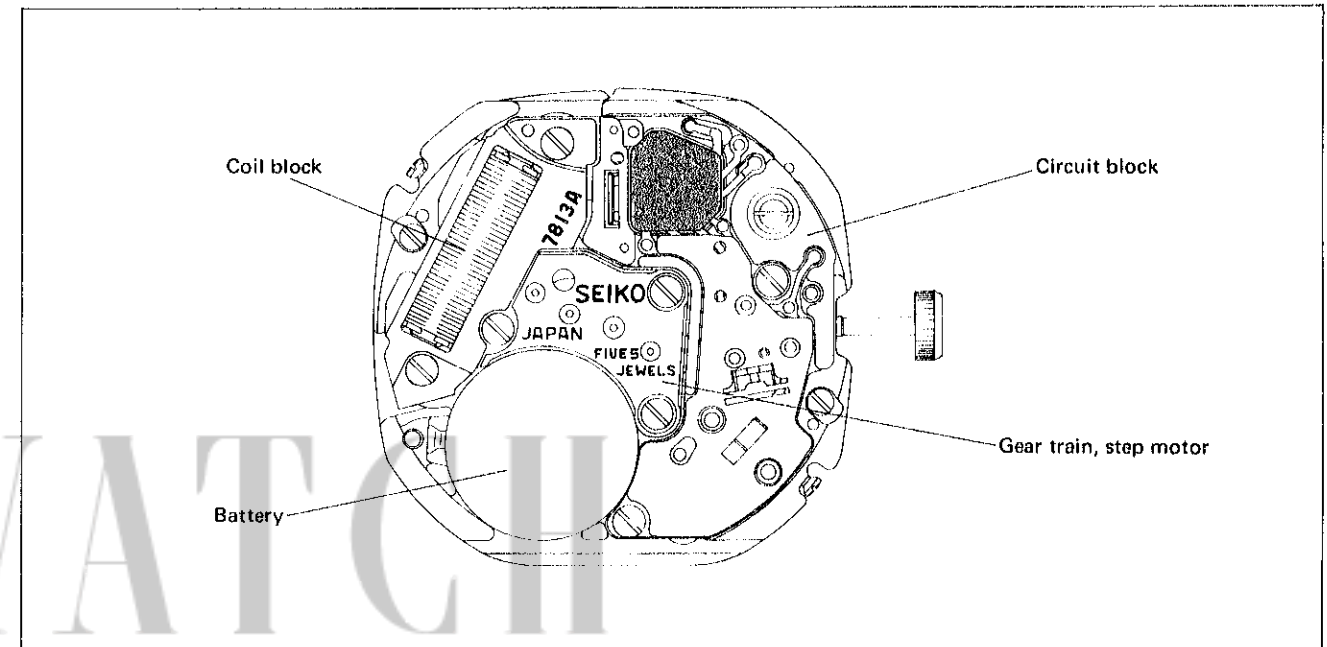

2. Outline of functioning

- (1) The quartz crystal oscillator, built in the crystal unit, oscillates accurately at 32,768 Hz.
- (2) The circuit unit receives the 32,768 Hz oscillations (electronic signals) and converts them into impulses at the rate of one per second, i.e. 1/2, 1/2, 1/2. . . .
- (3) The one-per-second signals are transmitted to the coil block, causing the step motor to momentarily rotate once every second in 180° increments.
- (4) This rotation is transmitted to the gear train thus moving the hands.

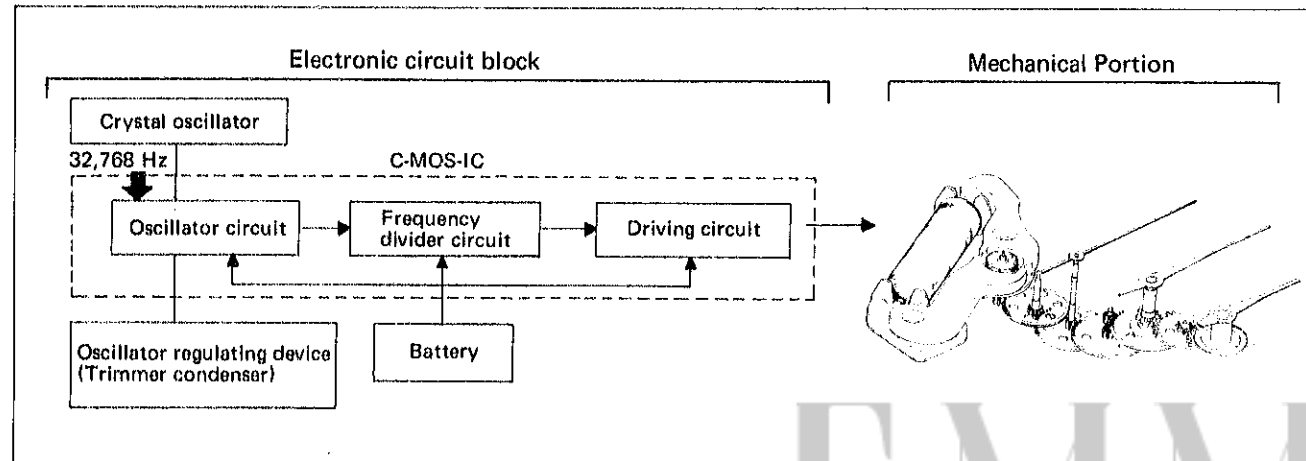

3. Functioning electronic circuit block

(1) Circuit block

- The quartz crystal oscillator, having been specially treated, is a tuning fork shaped oscillator that is ultra-small and by far thinner than ordinary ones. In order to secure long stability and to protect against outside influences, the crystal oscillator is housed in a cylinder-type vacuum capsule. When voltage is supplied from the electronic circuit, the crystal oscillator makes stabilized oscillations exactly at 32,768 Hz.

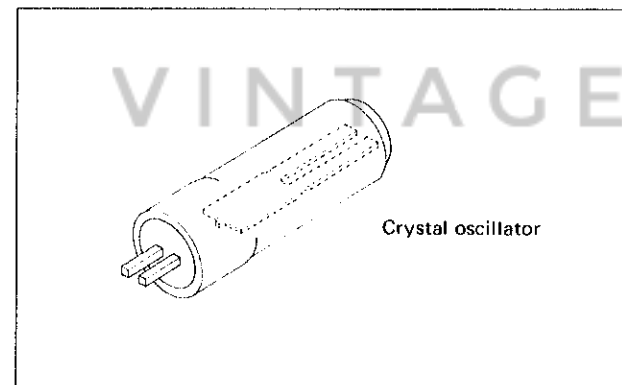

- The C-MOS-IC consists of the oscillator circuit, frequency divider circuit and driving circuit, and is connected electrically with the other electronic parts by the lead terminal. The oscillator circuit supplies voltage to the crystal oscillator to cause it to oscillate at 32,768 Hz and at the same time it takes out the oscillations in the form of an electrical signal. The frequency divider circuit divides the 32,768 Hz electrical signal so that it finally obtains one signal per second, which is transmitted to the step motor through the driving circuit.

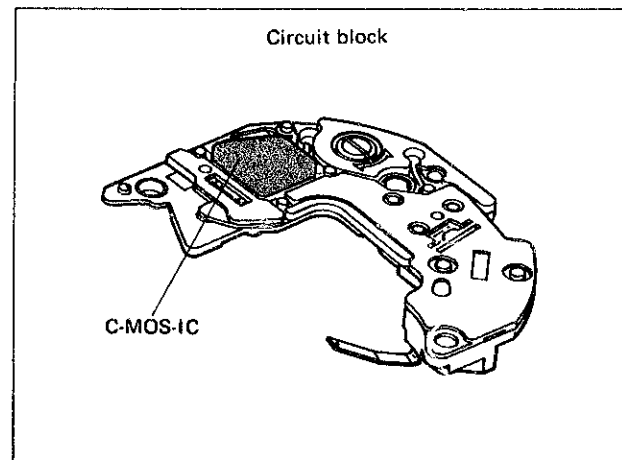

(2) Oscillator regulating device

Adjustment of the oscillator of Cal. 7813A watch can be easily made by simply turning the trimmer condenser.

- **Function of the Trimmer Condenser**
The trimmer condenser consists of a rotor electrode and a stator electrode. Turning the shaft fixed to the rotor changes the overlapped area between the rotor electrode and stator electrode, which in turn changes the capacitance of the trimmer condenser. Turning the trimmer condenser changes its capacitance as shown in the diagram. Time is adjusted by the magnitude of this change.

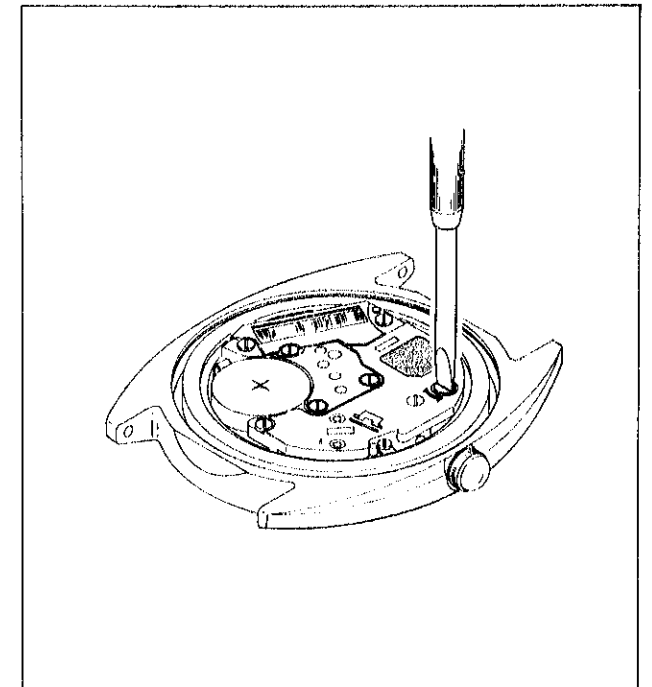

- Checking accuracy cannot be made with conventional mechanical wristwatch testing equipment. It is necessary to use a QUARTZ TESTER.

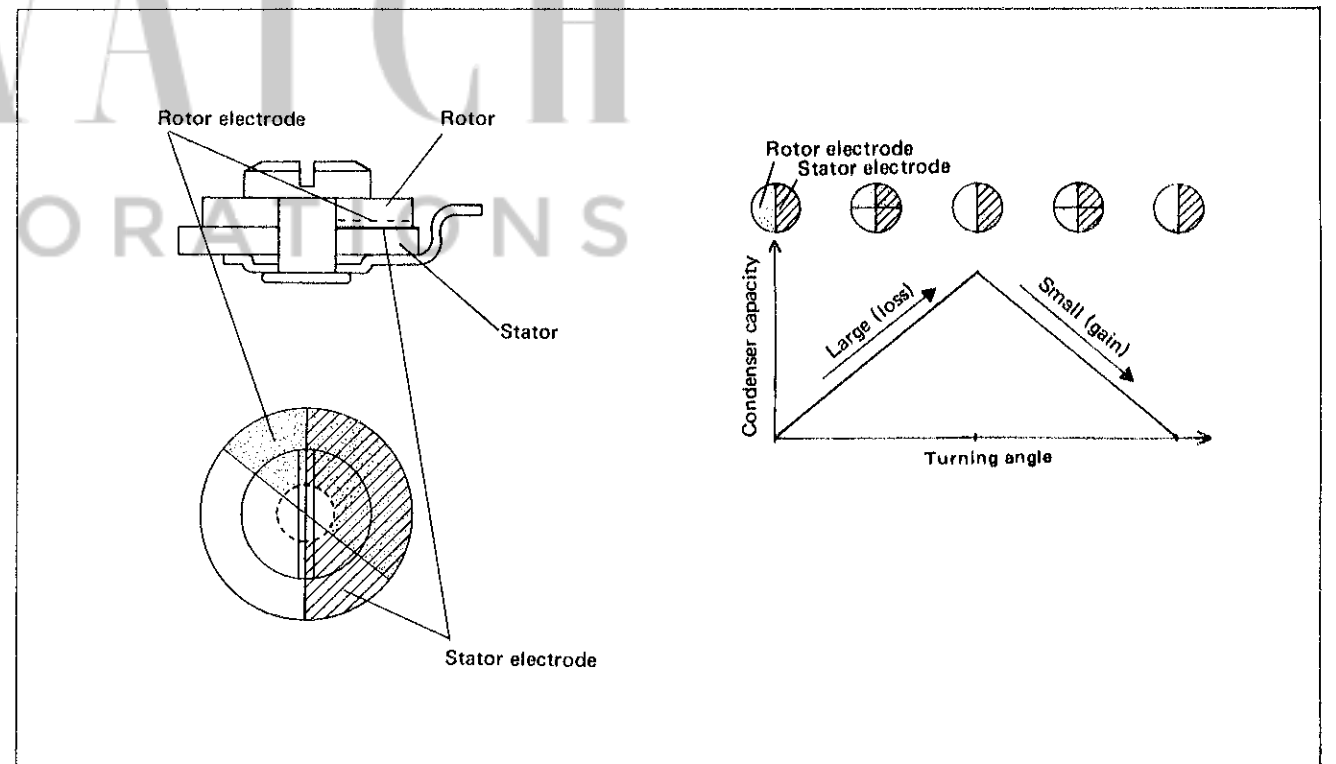

4. Functioning of mechanical portion

(1) Step motor

One of the features of these watches is the SEIKO step motor which changes the vibrations of the crystal oscillator into a rotating motion. The step motor consists of a coil block, a rotor stator and a step rotor. The rotor stator is made of materials having a high conductivity of magnetic force.

The step rotor is a circular-shaped permanent magnet having two alternately imposed N and S poles.

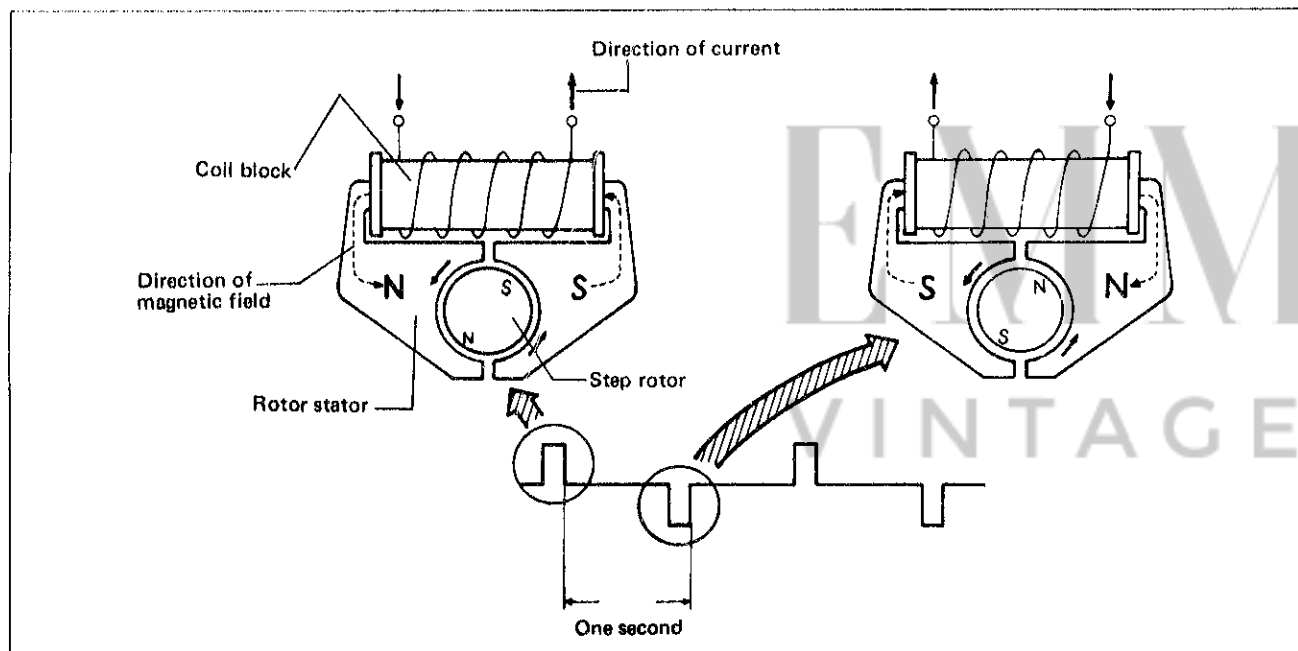
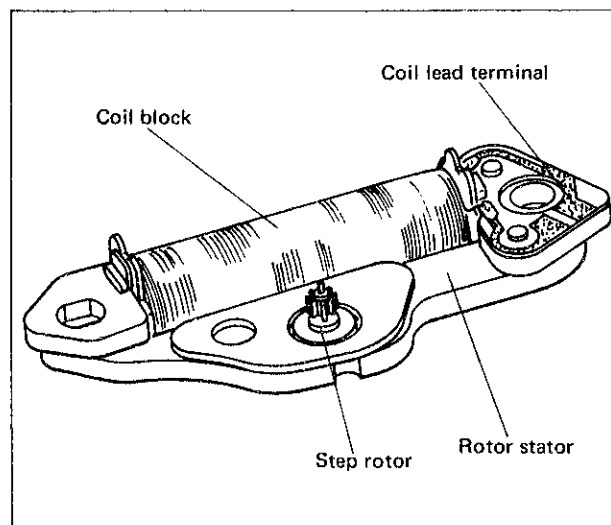

Operational sequence

(1) Current flows into the coil block

The current, of which the flow direction is changed once every second, is transmitted from the circuit block into the coil block.

(2) Rotor stators become magnets

When current flows in the coil block, the two rotor stators become magnets and the tip portions become, respectively, N and S poles.

(3) Step rotor rotations

The N and S poles of the rotor stator tips and the N and S poles of the step rotor alternately repel and attract causing the step rotor to rotate in 180° increments in a constant direction once every second.

(4) Rotation of the second hand

Rotation of the step rotor is transmitted to the fifth wheel and pinion which gears with the pinion of the step rotor. The rotation of the fifth wheel and pinion is in turn transmitted to the fourth wheel and pinion which gears with the pinion of the fifth wheel. The rotation of the fourth wheel and pinion moves the second hand.

(2) Second setting and reset switch

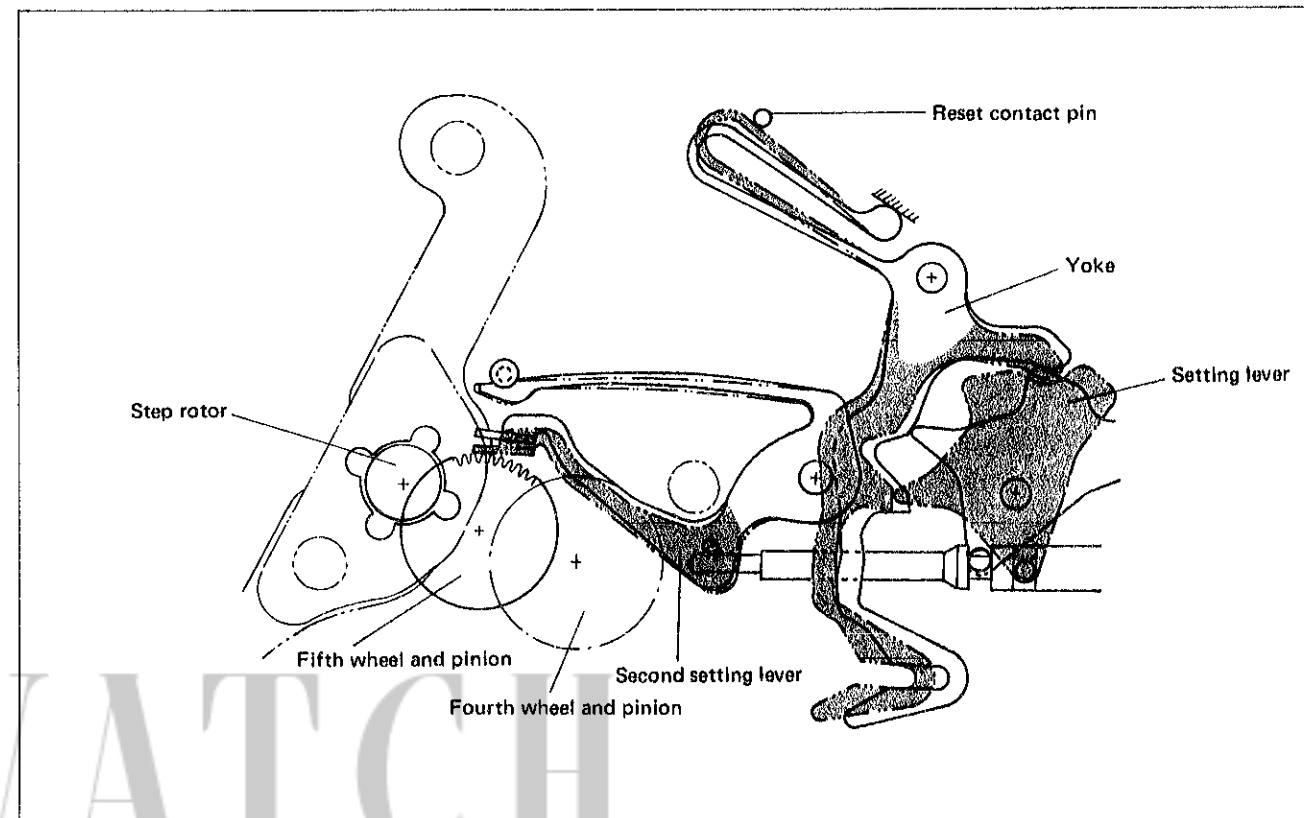

• Second setting device

When the crown is pulled out to the second click position, the second setting lever pin is disconnected from the tip of the winding stem and setting lever touches the fifth wheel. This stops the gear train from moving and the second hand stops at the desired second position.

• Reset switch

When the crown is pulled out to the second click position, the second hand stops moving and at the same time the setting lever pushes the yoke. This in turn lets the spring portion of the yoke touch the reset contact pin and the reset switch is set in the ON position. When the reset switch is in the ON position, the output signal of the circuit block stops. However, the electric current is still flowing from the battery to the crystal oscillator and the electronic circuit, and the watch is ready to start.

III. HOW TO SET THE TIME AND CALENDAR

• Crown position

- Normal position: Free
- 1st click: Change of day and date
 - Date change . . . clockwise (turn away from you.)
 - Day change . . . counterclockwise (turn towards you.)
- 2nd click: Hand setting, reset switch and second setting

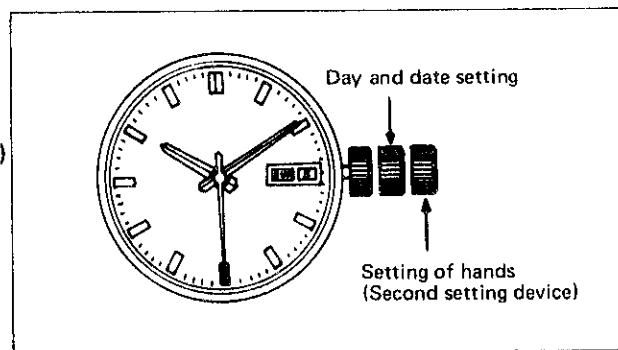

1. To set the hour

(1) Pull out the crown to the second click position

The second hand stops on one of the second markers.

(2) Turn the crown and set the time of the hour hand and minute hand.

- First turn the hour hand past the 12 o'clock position to see if the date changes, then set the time correctly. (Allow for the AM & PM period so that the date will change at midnight.)
- As the torque of the gear train is transmitted reversely, the time is set accurately by turning the hands between 5 to 10 minutes ahead and then turning it back to the desired time.

(3) Push in the crown in accordance with a time signal, and the time can be set as accurately as to the second.

2. Resetting calendar

• Pull the crown out to the 1st click.

Select the desired language as two languages appear alternately when setting the day of the week.

If the setting of the calendar is made when the hour hand is pointing to the time between 10:30 pm and 4:30 am, sometimes the calendar will not change to the next day. The setting must therefore be made before or after this time period.

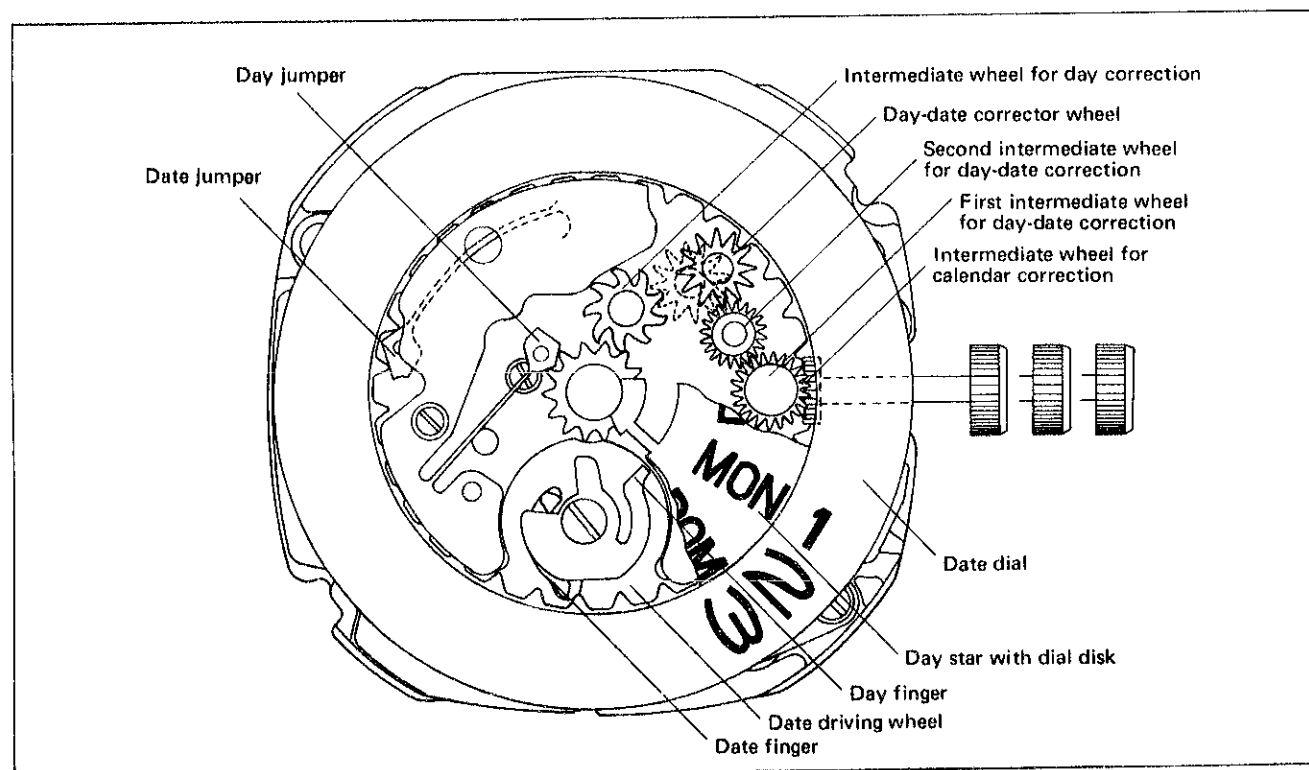

IV. CASE CONSTRUCTION

1. Case construction

The case constructions of the Cal. 78 series are roughly classified into the following two types.

(1) Snap type

The glass adheres to the caseband. The case is a snap type. The movement is fixed in the case ring by the casing clamp screw. The case ring is fixed to the caseband by the case back with the holding gasket for movement.

Starting model: 7800-8009
7813-8009
7813-8019

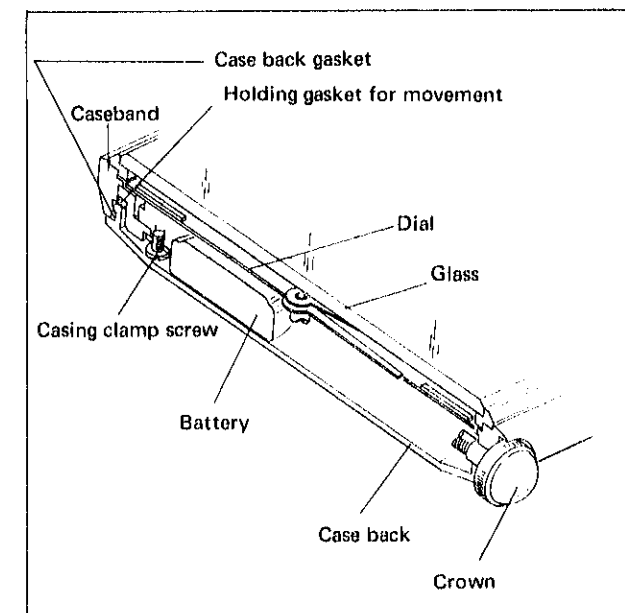

(2) Square type

The glass adheres to the caseband. By matching and pressing the four protrusions of the case back into the four grooves of the caseband, the caseband and the case back are fixed.

The movement is fixed to the caseband with the case ring.

Starting model: 7800-5009
7810-5009
7810-5019

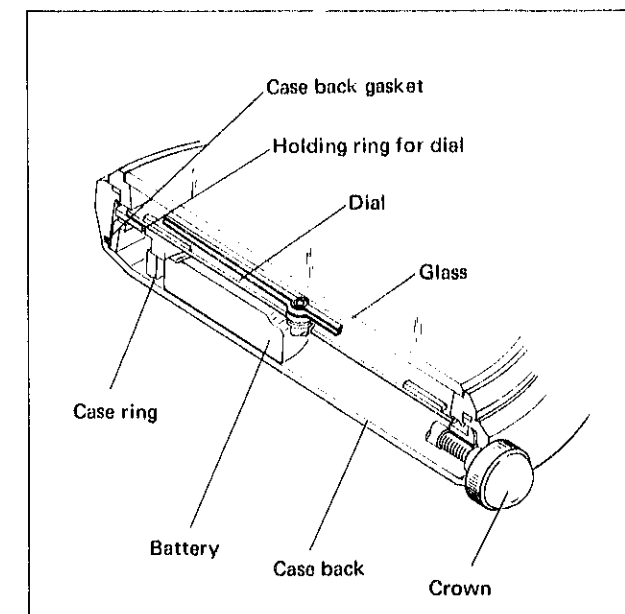

2. Remarks for handling the case

(1) Snap type

Remarks for disassembling

- Pry open the case back by using the case opener while supporting it by the case lug.
(Be careful not to damage the case back gasket by inserting the tip of the case opener too deep.)

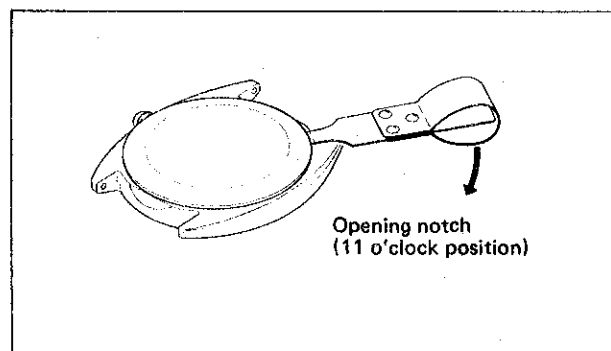

- The holding gasket for movement is cut so that it does not prevent the crown with stem from being set in position. The holding gasket for movement should have the cut to hold the crown with stem.
- The case back gasket is set in the case back.
- Be sure that the crown with stem is in the completely pushed in position (in the second click position for Cal. 7813A) when it is disassembled.
(The yoke and the setting lever overlap each other if the crown with stem is disassembled from the pulled out position.)

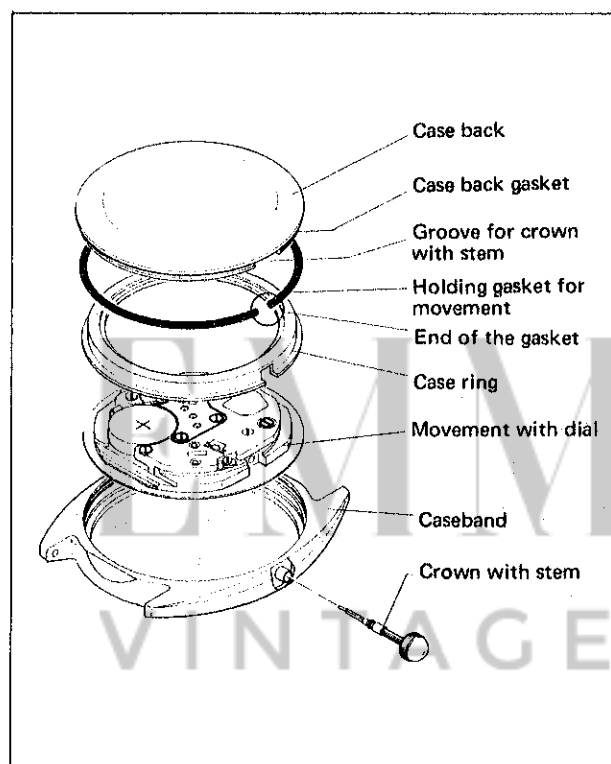

Remarks for reassembling

- Be sure that the groove of the case back is set to the proper position for the crown with stem when pushing the case back in position.
(There is the positioning mark inside the case back.)
- Be sure to wipe filings off the case back gasket if there is any.

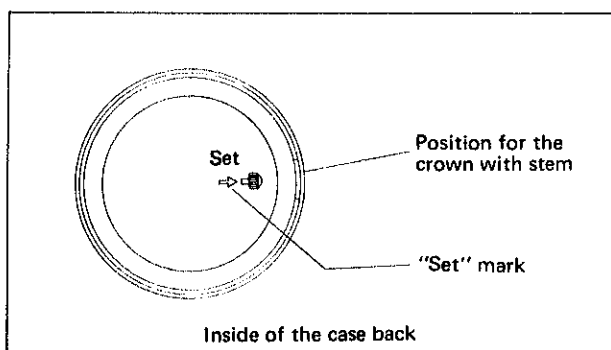

(2) Square type

The remarks for disassembling and reassembling are the same as those for the existing square type calibres.

3. Battery replacement

When the battery life nears its end, the second hand starts to move in two seconds interval instead of the normal one second interval.

(The watch, however, remains accurate as the second hand moves two seconds at a time.)

Be sure to replace the battery when the second hand starts to move in two second intervals.

V. AFTER-SALE SERVICING INSTRUMENTS AND MATERIALS

For repair servicing, the following SEIKO after-sale servicing instruments and materials are necessary. These instruments and materials are available at the technical services office of SEIKO.

1. Quartz Tester

Used to check time accuracy (daily rates) and flow of current from circuit block.

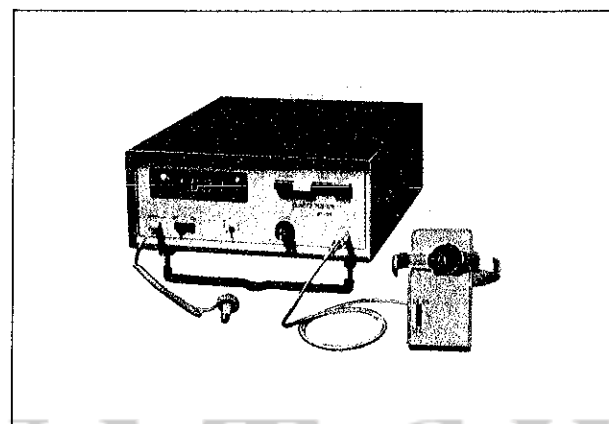

4. Movement holder

Choose one of the movement holders of the 56 series in the movement holder unit S-680.

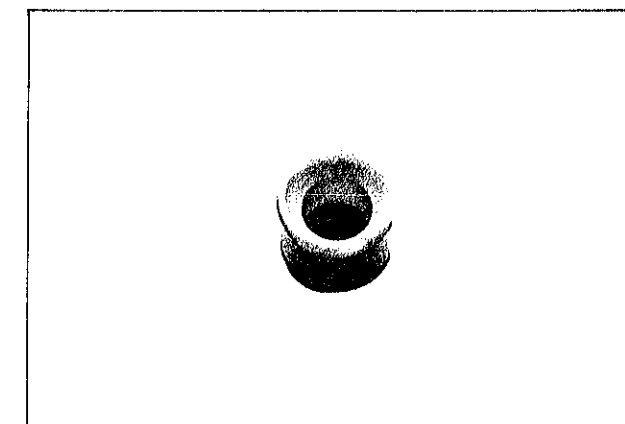

2. Micro Test MT-10II

Used to check current consumption and to give constant voltage.

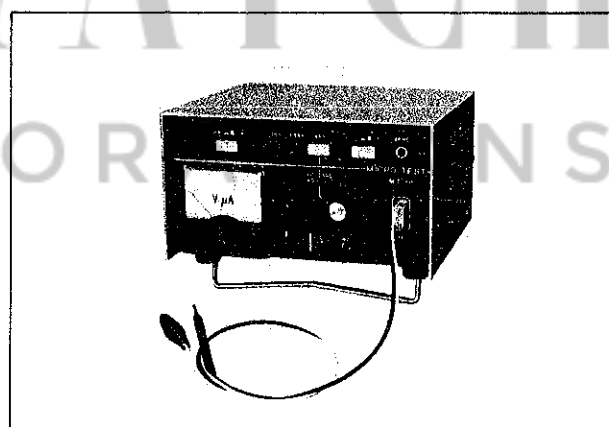

5. Others

- (1) Anti-magnetic tweezers for handling step rotor.
- (2) Non-metallic tweezers for handling battery.

3. Volt-ohm-meter

Used for checking battery voltage, measuring resistance and conducting conductivity test.

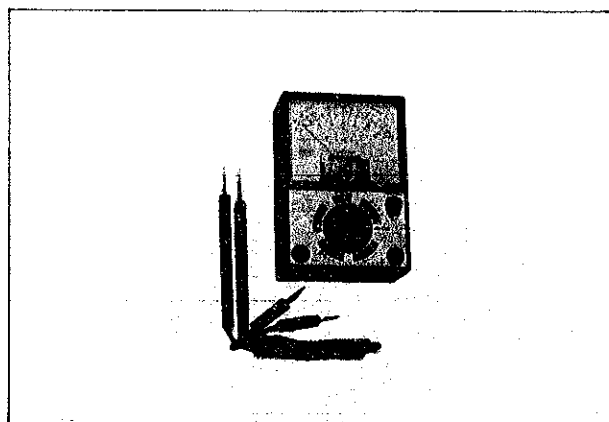

VI. DISASSEMBLING, REASSEMBLING, LUBRICATING AND CLEANING

1. Disassembling, Reassembling and Lubricating

(1) Disassembling, reassembling and lubricating of the calendar mechanism.

Disassembling procedures Figs.: ① → ④④

Reassembling procedures Figs.: ④④ → ①

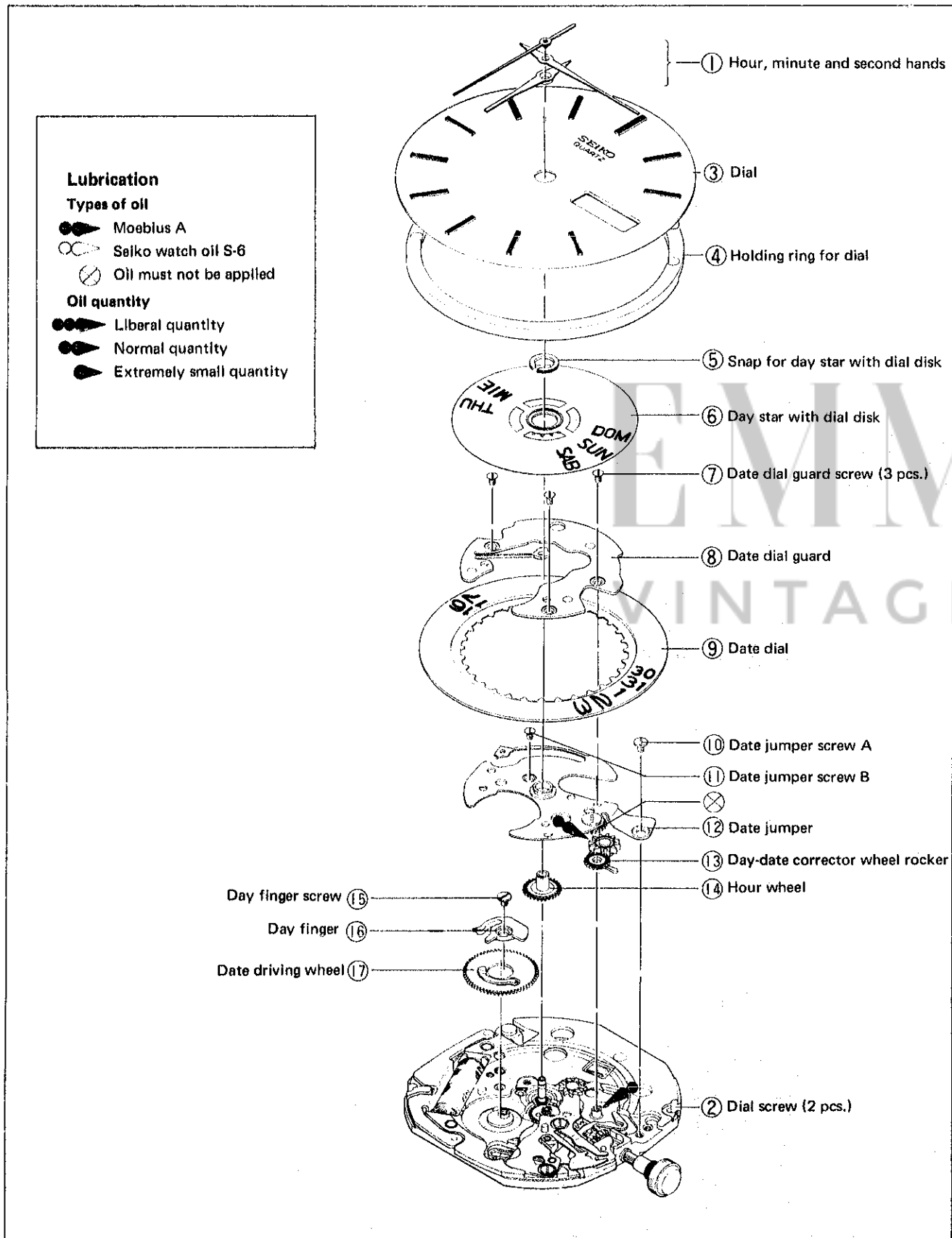

Remarks for disassembling and reassembling

① Hour, minute and second hands

Remarks for disassembling and reassembling

- Pull out the crown to the second click position for disassembling and reassembling.
- Be sure to assemble the second hand exactly on the second mark. (Both odd and even second marks will do.)
- When reassembling, be careful that the hands do not touch each other as the watch is so thin that the clearance between the hands is less than that for ordinary type watches.

⑤ Snap for day star with dial disk

Remarks for disassembling

- Push the thin tip of a screw driver into the groove of the snap for day star with dial disk.

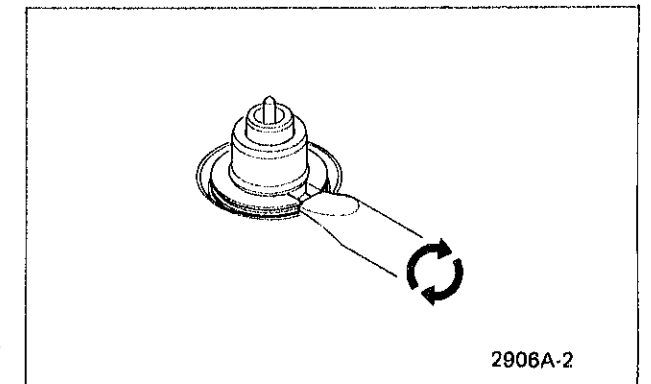

⑬ Day-date corrector wheel rocker

Remarks for reassembling

- Lubricate the day-date corrector wheel as shown in the illustration on the left.
- Pull out the crown to the first click position and reassemble.

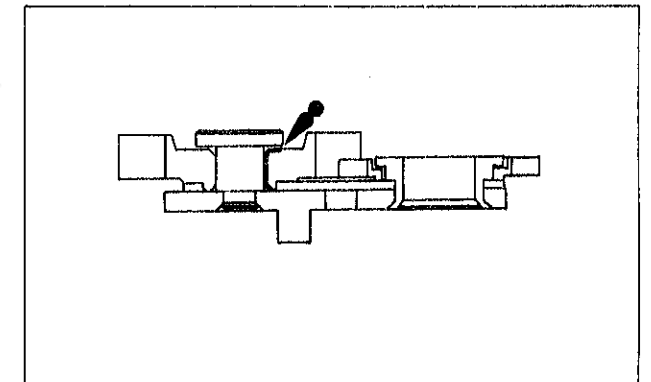

⑯ Day finger

Remarks for reassembling

- Reassemble so that the date driving wheel pin is positioned as shown in the illustration on the left.

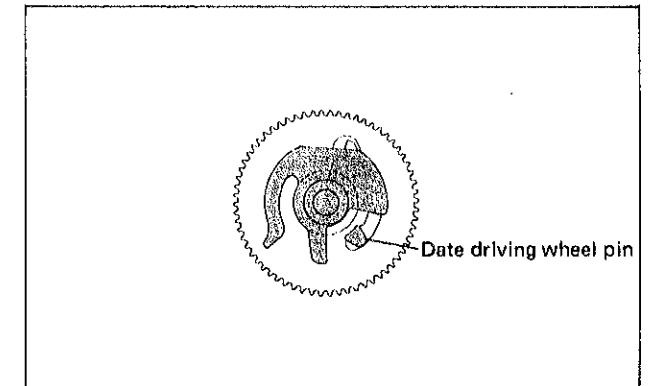

(2) Disassembling, reassembling and lubricating of the circuit block, coil block and gear train.

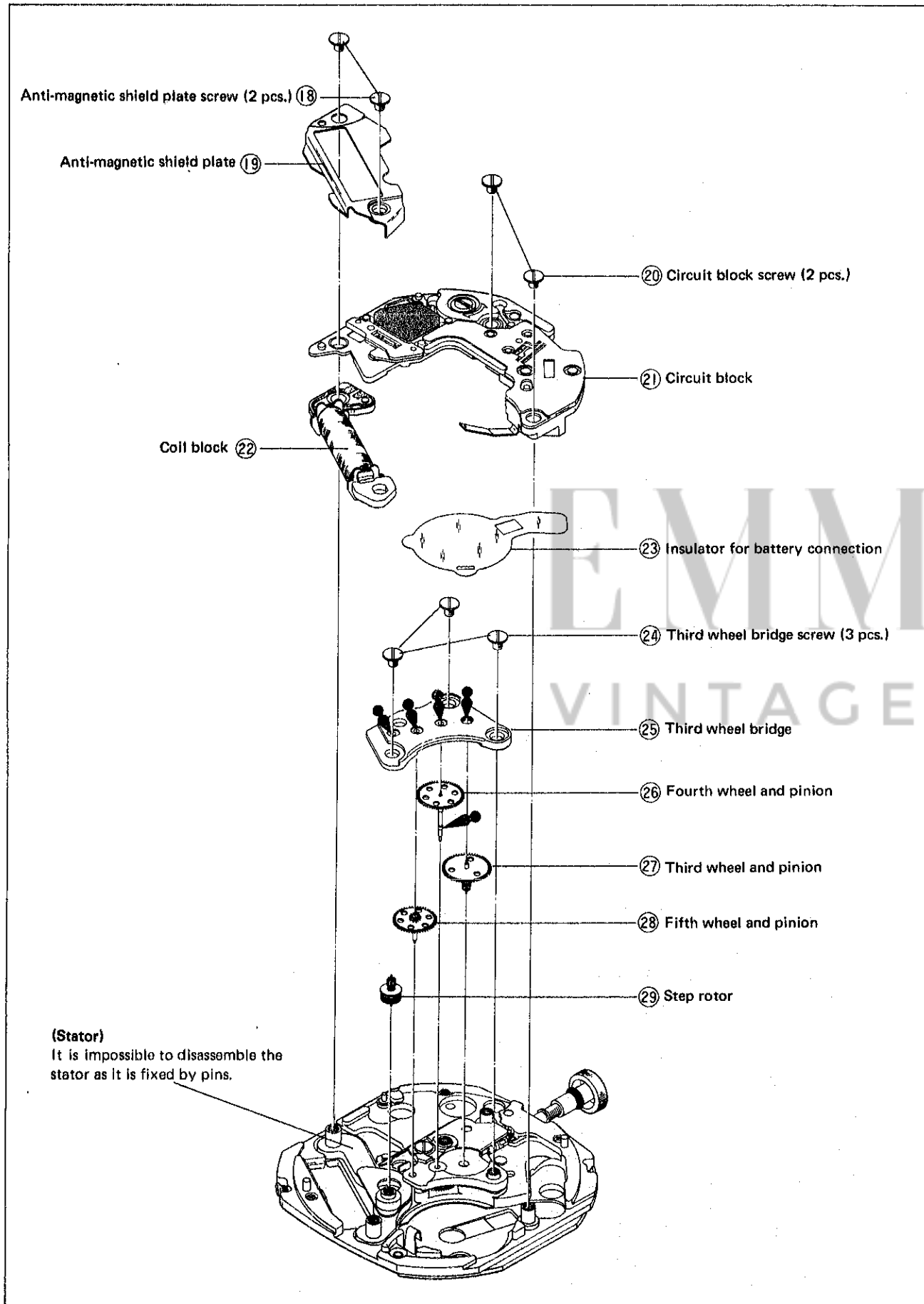

Remarks for disassembling and reassembling

(19) Anti-magnetic shield plate

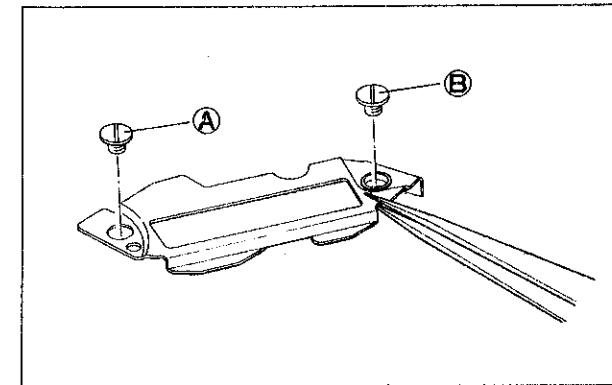

Remarks for disassembling and reassembling

- Disassemble by holding the portion with tweezers as shown in the illustration on the left.
- Be careful in handling as the anti-magnetic shield plate is easy to bend.
- Be sure to tighten the anti-magnetic shield plate screw (A) first and then (B) next. (If (B) is tightened first, it will be difficult to tighten (A) as (A) portion of the anti-magnetic shield plate lifts up.)

(22) Coil block

Remarks for disassembling and reassembling

- Be careful not to damage the coil wire and the lead terminal. Handle them as shown in the illustration below.

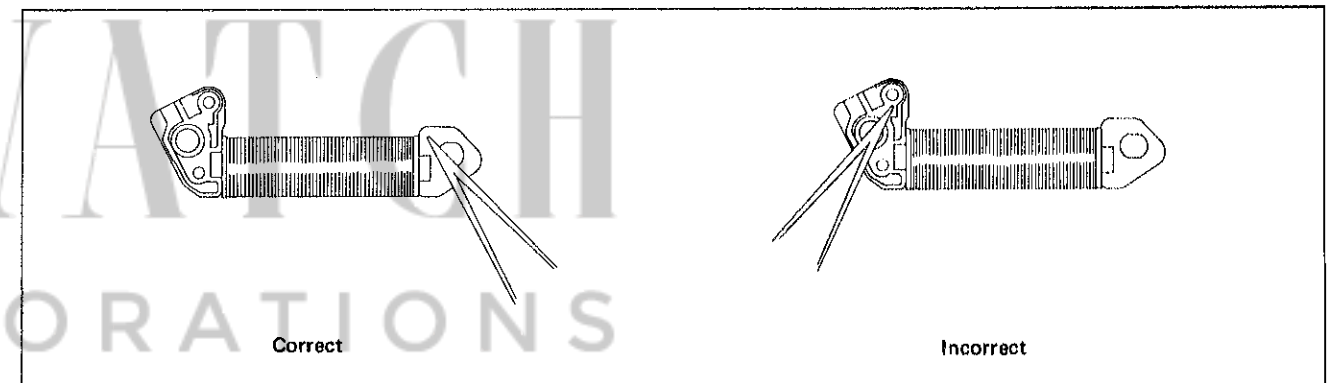

(29) Step rotor

Remarks for reassembling

- Check the clearances for the upper and the lower pivots for the step rotor after reassembling the anti-magnetic shield plate.

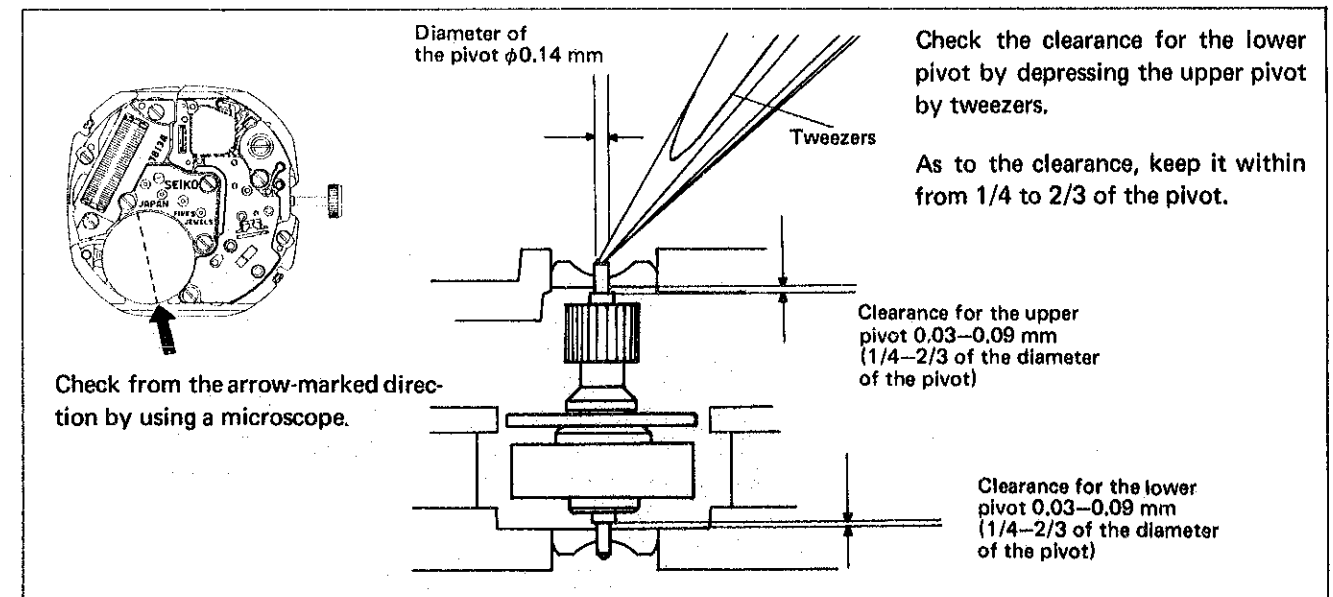

(3) Disassembling, reassembling and lubricating of the setting mechanism.

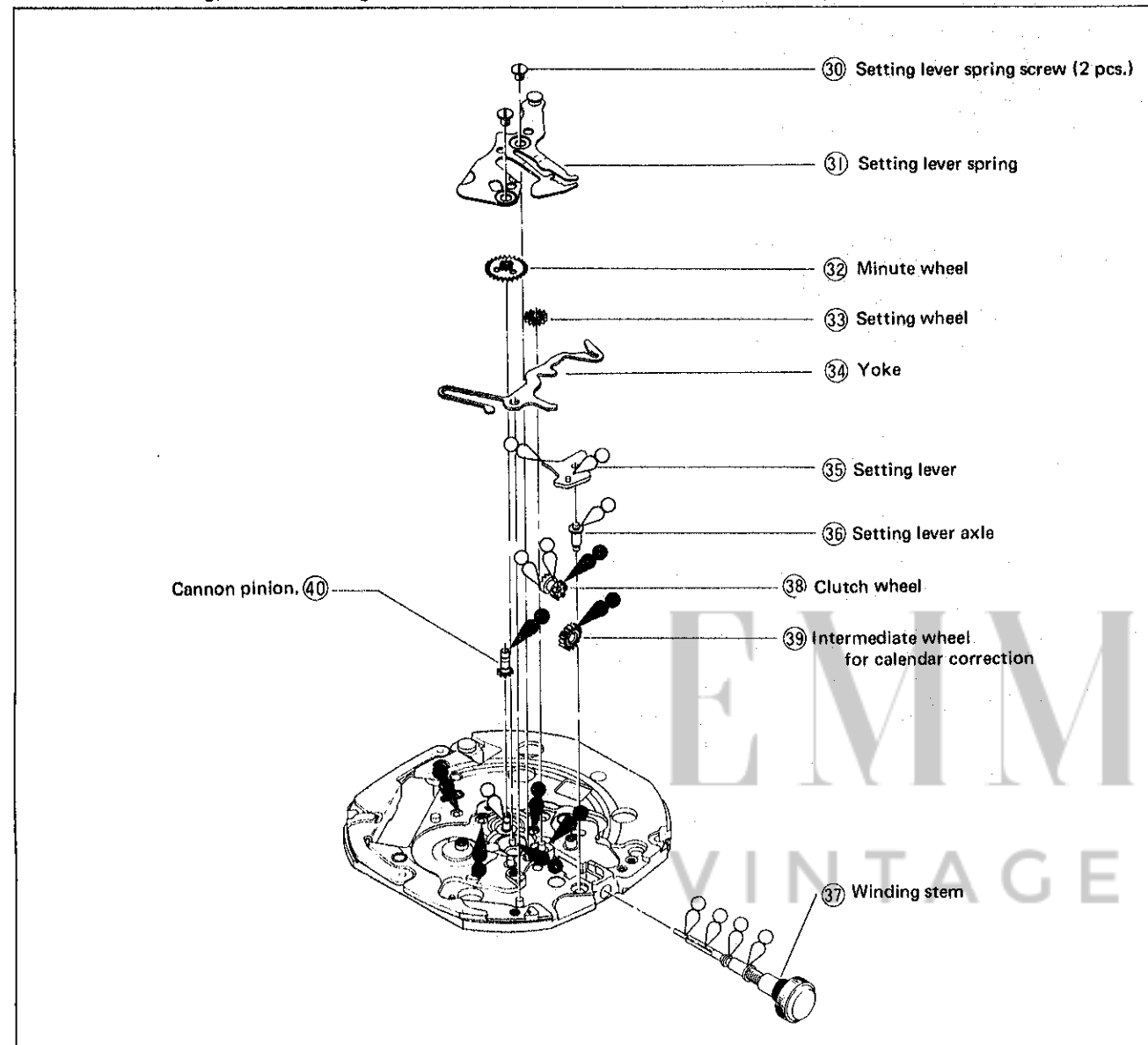

(4) Disassembling, reassembling and lubricating of the center wheel bridge ~ the center wheel.

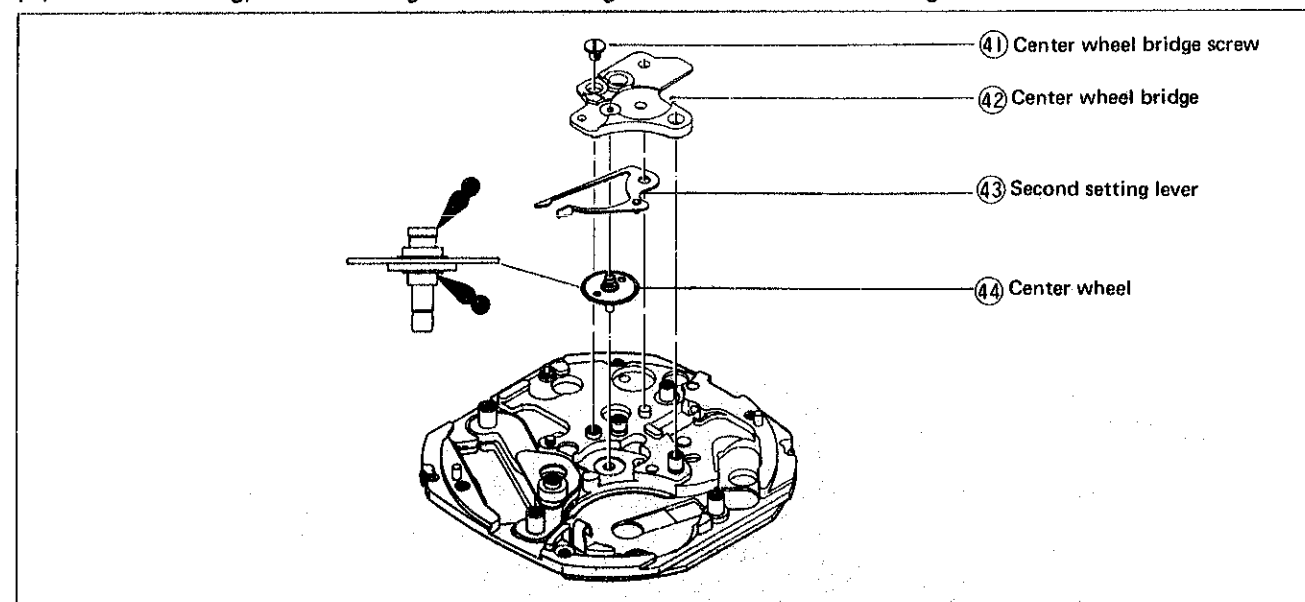

Remarks for disassembling and reassembling

31 Setting lever spring

Remarks for disassembling

- Pry up the arrow-marked portion (A) slightly and remove the arrow-marked pin (B) (positioned under the intermediate wheel for day correction). Then pry up the setting lever spring for disassembling by holding the portion (A).

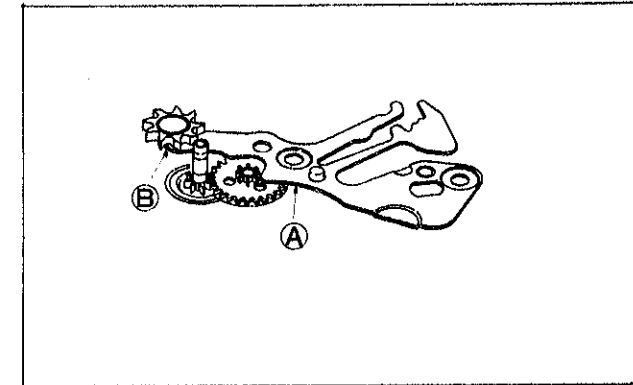

37 Winding stem

38 Clutch wheel

39 Intermediate wheel for calendar correction

Remarks for reassembling

- Reassemble after reassembling the center wheel bridge. (It is difficult to reassemble the clutch wheel and the intermediate wheel for calendar correction if the center wheel bridge is not reassembled.)
- Refer to the illustration below for the direction of reassembling and the lubricating.

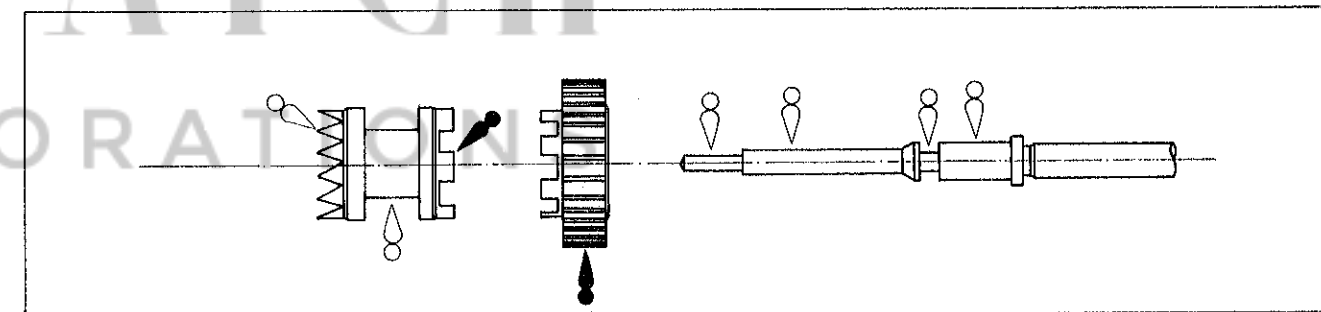

43 Second setting lever

Remarks for reassembling



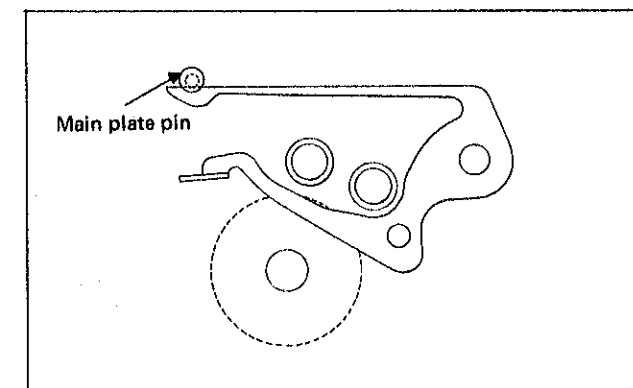

- Hook the spring portion to the main plate pin as shown in the illustration on the left.
- Be sure to pull out the winding stem all the way and then reassemble the second setting lever when the setting mechanism is already reassembled.



2. Cleaning

Since several special parts (electronic, etc.) used in the Cal. 7813A differ from conventional mechanical watches, use the following cleaning methods when cleaning.

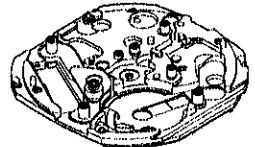
HOW TO CLEAN

Name of parts	Cleaning	Drying	Solution	Remarks
(1) Circuit block  Coil block 	DO NOT CLEAN			<ul style="list-style-type: none"> Conductive portion ONLY may be cleaned with a cloth moistened with benzine or alcohol. Dry in COOL air.
(2) Main plate  Step rotor  Plastic parts Day finger Date driving wheel Insulator for battery connection	Rinse or scrub with a soft brush	Cool air drying	Benzine, alcohol	<ul style="list-style-type: none"> Be careful not to remove the parts fixed to the main plate. Use a clean solution as the step rotor is magnetized. Any foreign matter which cannot be removed by cleaning should be removed with rodico or adhesive tape. When cleaning with benzine, the cleaning time should be minimized.
(3) Others	Clean with the cleaner, rinse or gently scrub with a soft brush.	Cool or hot air drying	Benzine, trichloroethylene, alcohol	<ul style="list-style-type: none"> Be careful not to bend the anti-magnetic shield plate.

EMMY WATCH RESTORATIONS

VII. CHECKING AND ADJUSTMENT

1. Guide table for checking and adjustment

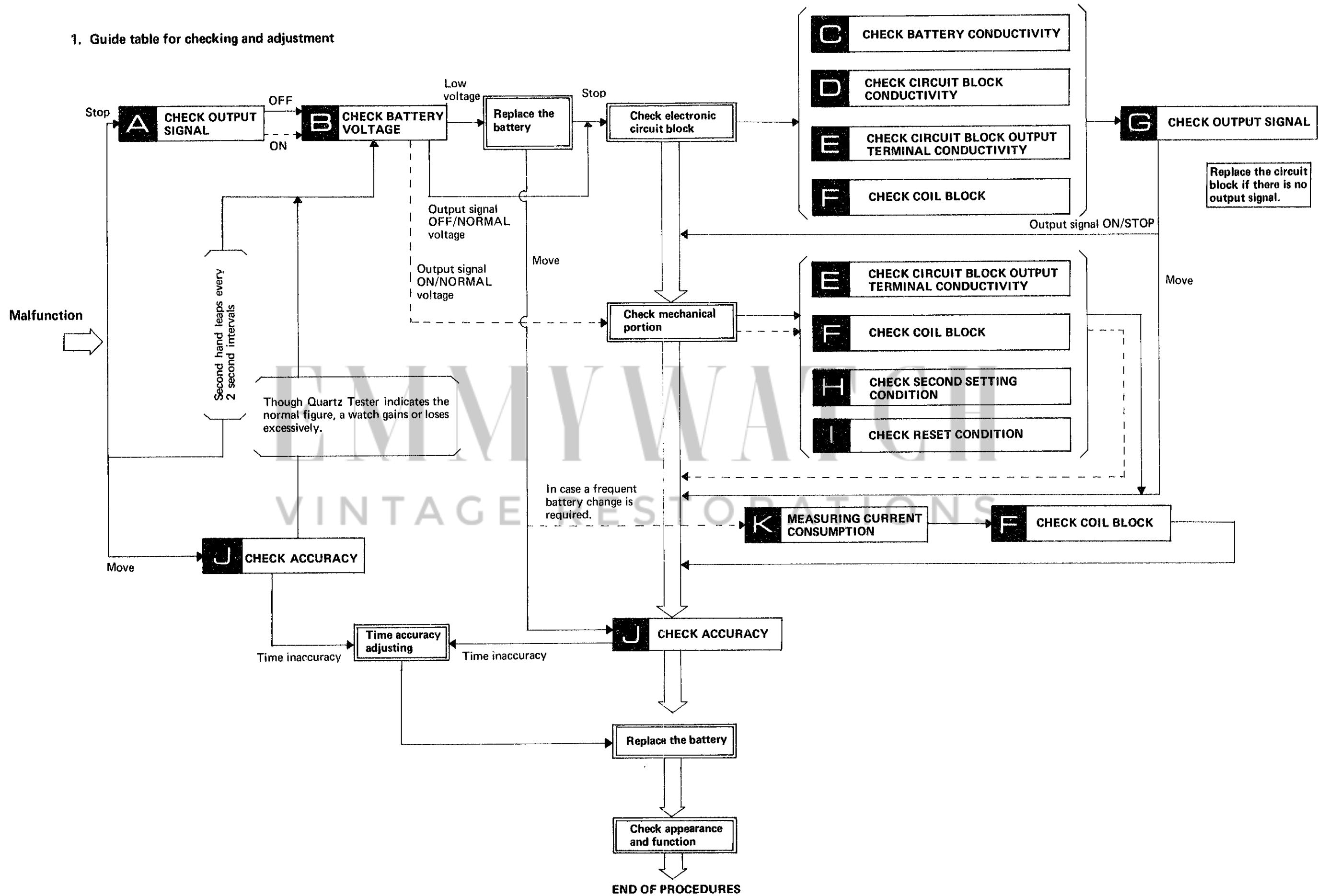

2. Procedures for checking and adjustment

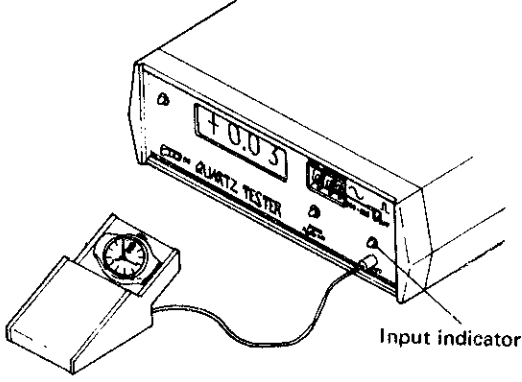
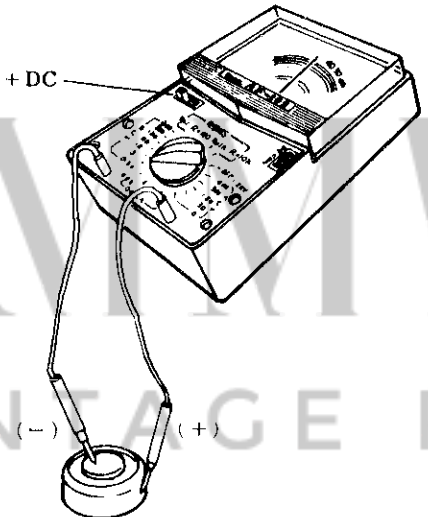
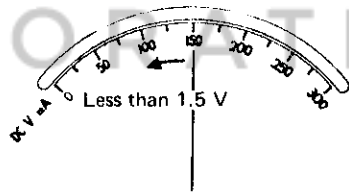
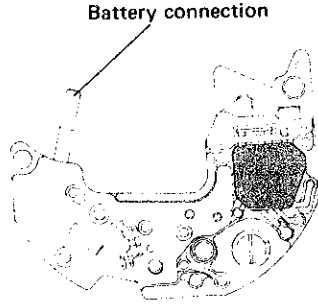
	Procedure	Result	Adjustment and Repair
<p style="writing-mode: vertical-rl; transform: rotate(180deg);">CHECK OUTPUT SIGNAL</p>	<p>Check output signal</p> <p>(1) Set up the Quartz Tester.</p> <p>(2) Checking Check for blinking input indication light.</p> <div style="border: 1px solid black; padding: 5px; margin-top: 10px;"> <p><Note> The checking must be made when the crown is in the normal position.</p> </div> 	<p>One-second blinking . . . Normal</p> <p>No one-second blinking . . . Defective</p>	<p>Proceed to E.</p>
<p style="writing-mode: vertical-rl; transform: rotate(180deg);">CHECK BATTERY VOLTAGE</p>	<p>Use the following procedures to check battery voltage.</p> <p>(1) Set up the volt-ohm-meter Range to be used: DC 3 V</p> <p>(2) Measuring Probe Red Battery surface (+) Probe Black Battery surface (-)</p> <div style="border: 1px solid black; padding: 5px; margin-top: 10px;"> <p><Note> When handling the battery, use non-metallic tweezers or a fingertip.</p> </div> <div style="border: 1px solid black; padding: 5px; margin-top: 10px;"> <p>When there is battery electrolyte leakage, refer to "HOW TO CHECK BATTERY ELECTROLYTE LEAKAGE AND REPAIR" below for repairing.</p> </div> 	<p>More than 1.5 V . . . Normal</p> <p>Less than 1.5 V . . . Defective</p> 	<p>Proceed to Check mechanical portion if one-second blinking is found.</p> <p>Proceed to Check electronic circuit block if one-second blinking is not found.</p> <p>Replace circuit block if the second hand leaps every 2 seconds.</p> <p>Proceed to Replace the battery</p> <ul style="list-style-type: none"> • If the watch operates after battery replacement, proceed to J. • If the watch does not operate, proceed to Check electronic circuit block
<p style="writing-mode: vertical-rl; transform: rotate(180deg);">HOW TO CHECK BATTERY ELECTROLYTE LEAKAGE AND REPAIR</p>	<ol style="list-style-type: none"> 1. Remove the movement from the case. 2. Disassemble the movement. 3. Wipe off battery electrolyte on the circuit block. <ol style="list-style-type: none"> (1) Wipe off battery electrolyte on the circuit block with a cloth moistened with distilled water. (If distilled water is not available, use ordinary water.) (Do not use cloths which give off lint such as gauze, flannel, etc.) <p style="margin-top: 20px;">Do not expose the trimmer condenser to water or alcohol, and if it is exposed, there may be a change in its condenser capacity and eventually in the time accuracy.</p> 	<p>Be sure to clean the battery connection.</p> 	<ol style="list-style-type: none"> (2) Wipe with a cloth moistened with alcohol. (If the cleaned portions remain wet with water, they will corrode with rust.) (3) Dry with cool air by using a dryer. 4. Wipe off battery electrode on the other parts by referring to page 18. (Clean the insulator for battery connection with water.) 5. Reassemble the movement. (Replace the battery with a new one.) 6. Check to see if the time setting functions and the current consumption are normal.

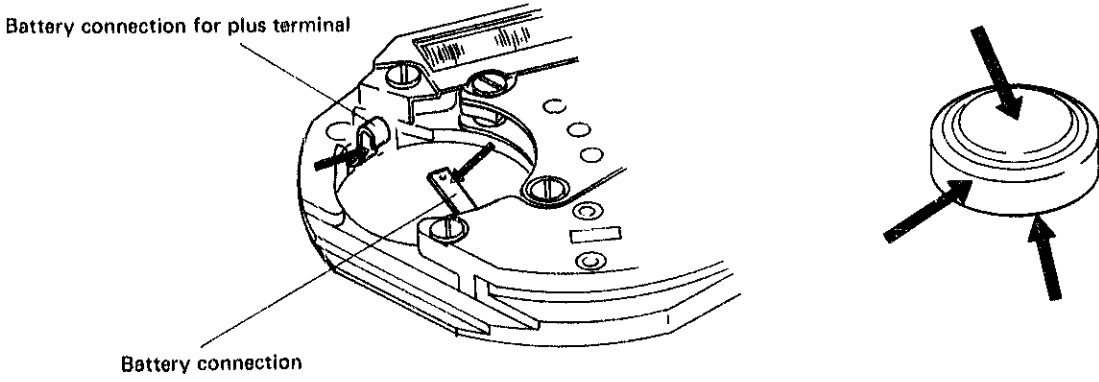
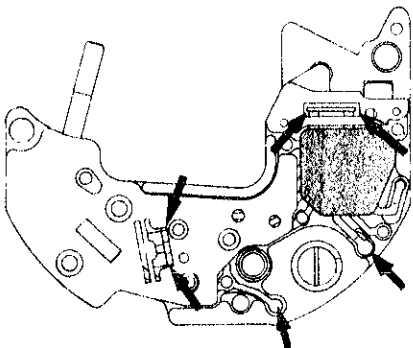
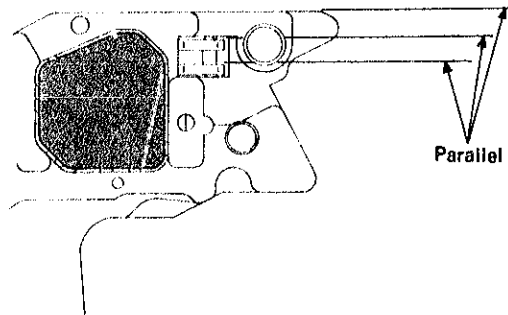
	Procedure	Result	Adjustment and Repair
C CHECK BATTERY CONDUCTIVITY	<p>Check to see if the battery current flow to the circuit is normal.</p> <p>(1) Check for any stain on the connecting portions of the battery, the battery connection for plus terminal and the battery connection.</p> 	<p>Untaminated . . . Normal →</p> <p>Contaminated . . . Defective →</p>	<p>Proceed to D .</p> <ul style="list-style-type: none"> Wipe off carefully . <div style="border: 1px solid black; padding: 5px; margin-top: 10px;"> <p><Note> Be careful not to bend the plus terminal of battery connection and the battery connection.</p> </div>
D CHECK CIRCUIT BLOCK CONDUCTIVITY	<p>Check for defective conductivity of the circuit block. Check conductivity of the arrow-marked portion by using a microscope.</p> 	<p>No defective conductivity . . . Normal →</p> <p>Defective conductivity . . . Defective →</p>	<p>Proceed to E .</p> <ul style="list-style-type: none"> Replace the circuit block with a new one.
E CHECK CIRCUIT BLOCK OUTPUT TERMINAL CONDUCTIVITY	<p>Check the connecting portions of the circuit block and the coil.</p>  <p>1. Check to see if the two output terminals are parallel to the edge of the circuit board when the circuit block is viewed from the back side.</p>	<p>Parallel . . . Normal →</p> <p>Bent . . . Defective →</p>	<p>Proceed to E 2 .</p> <ul style="list-style-type: none"> Correct the bend of the output terminal.

Procedures

Result

Adjustment and Repair

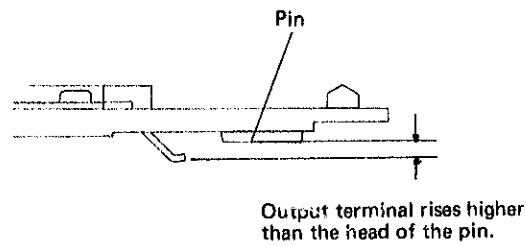

2. Check to see if the circuit block output terminal rises higher than the head of the pin for circuit block screw viewed from the side.

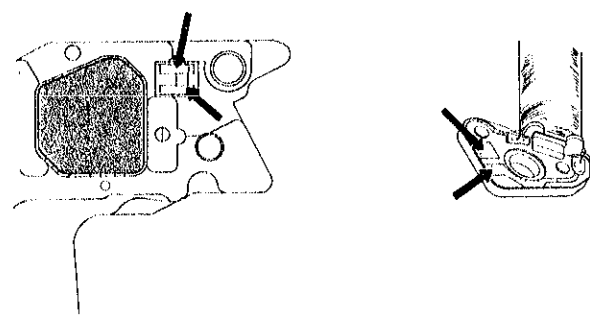

3. Check for any contamination on the circuit block output terminal and the coil lead terminal.

Higher . . . Normal → Proceed to **E** 3.

Not higher . . . Defective → • Raise the output terminal.

Uncontaminated . . . Normal → Proceed to **F**.

Contaminated . . . Defective → • Wipe off the contamination.

Check for broken coil wire and short circuit of the coil block.

(1) Set up the Volt-ohm-meter.

Range to be used: OHMS R X 100

(2) Checking

Apply the red and black probes of the Volt-ohm-meter to the two lead terminals of the coil.

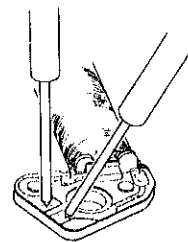

Color of coil frame

For Cals. 7800, 7810 . . . Green
For Cal. 7813 Gray

Pointer of the Volt-ohm-meter swings . . . Normal →

Broken coil wire
(Pointer of the Volt-ohm-meter hardly swings.) . . . Defective →

Short circuit
(Pointer of the Volt-ohm-meter swings excessively.) Defective

Proceed to **G** if Electronic circuit block must be checked.

Proceed to **H** if Mechanical portion must be checked.

• Replace the coil block with a new one.

Check for output signal.

(1) Set up the Quartz Tester.

(2) Checking

Follow the same procedures as in **A**.

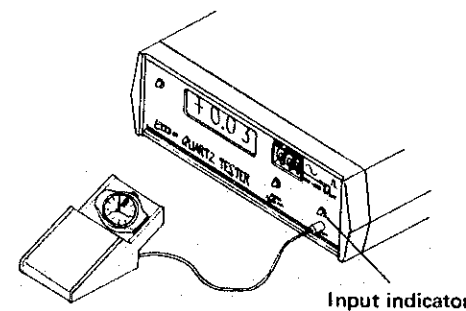

One-second blinking → Functioning → Proceed to **J**.
→ Not functioning → • **Check Mechanical portion** **H**.

No one-second blinking Defective → • Replace the circuit block with a new one.

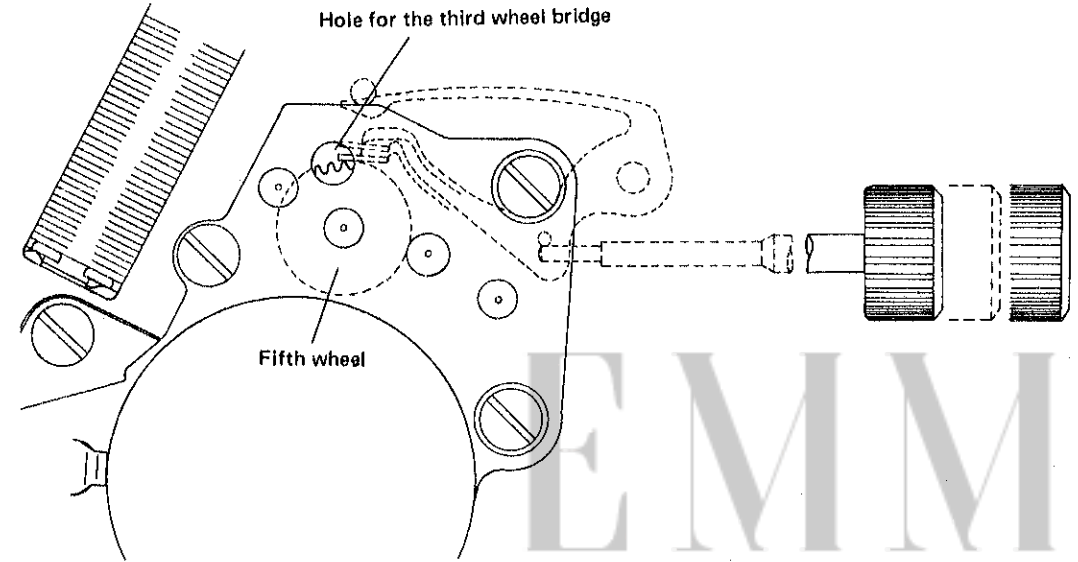
	Procedure	Result	Adjustment and Repair
CHECK SECOND SETTING CONDITION	<p>Check the second setting condition.</p> <p>Check to see if there is clearance between the second setting lever and the fifth wheel when the crown is in the normal and the first click positions. Also, check to see if the second setting lever touches the fifth wheel when the crown is in the second click position. (Check through the hole for the third wheel bridge by using a microscope.)</p>  <p>The diagram shows a top-down view of a watch movement. A second setting lever is positioned above the fifth wheel. A hole for the third wheel bridge is located between them. A microscope is shown pointing at the hole. A separate view shows the second setting lever with a curved tip.</p>	<p>Function . . . Normal →</p> <p>Do not function . . . Defective →</p>	<p>Proceed to I.</p> <ul style="list-style-type: none"> • Correct the bend of the second setting lever.
CHECK RESET CONDITION	<p>Check the reset condition after the circuit block and the battery are reassembled.</p> <ol style="list-style-type: none"> 1. Check to see if the second hand stops immediately when the crown is pulled out completely and if it starts promptly one second after the crown is pushed in to the normal position. 2. Check to see if the conductivity between the reset pin and the main plate is normal when the crown is pulled out completely. <p>(1) Set up the Volt-ohm-meter Range to be used: OHMS R X 1.</p> <div style="border: 1px solid black; padding: 5px; margin-top: 10px;"> <p><Note> Be careful not to use the range other than R X 1. The circuit might be damaged if another range is used.</p> </div>	<p>Stops completely and starts moving after one second . . . Normal →</p> <p>Does not stop or moves irregularly . . . Defective →</p> <p>Less than 10Ω . . . Normal →</p> <p>More than 10Ω . . . Defective →</p>	<p>Proceed to J.</p> <p>Proceed to I 2.</p> <ul style="list-style-type: none"> • Replace the circuit block with a new one. • The defect is caused by one of the reasons stated on page 29.

(to be continued on page 28)

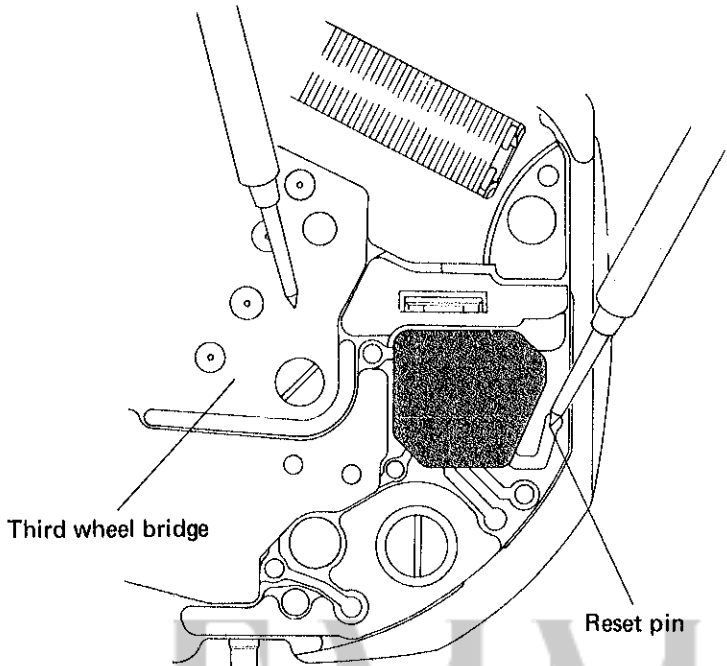
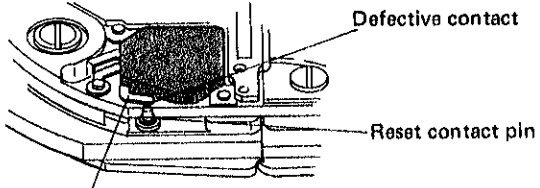
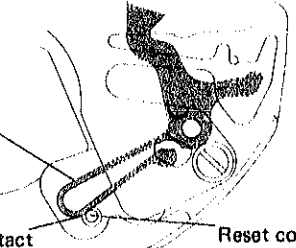
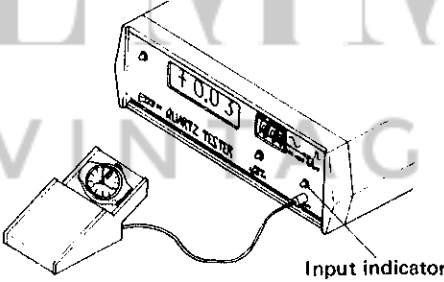
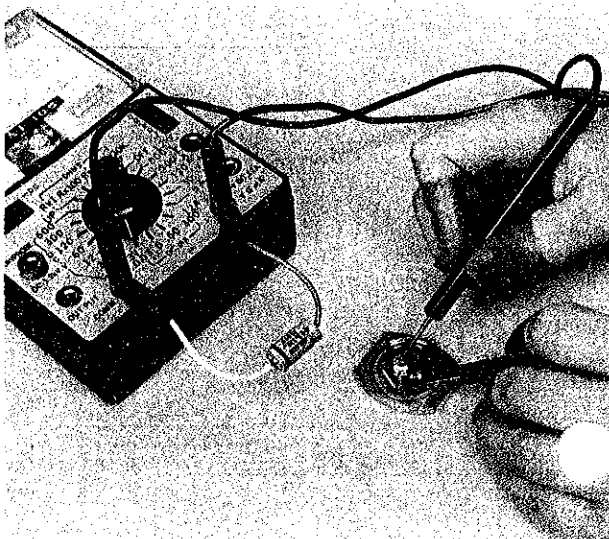
	Procedure	Result	Adjustment and Repair
CHECK RESET CONDITION	<p>(2) Checking Apply the probes of the Volt-ohm-meter to the third wheel bridge and the reset pin.</p> <div data-bbox="311 527 605 621" style="border: 1px solid black; padding: 2px; width: fit-content;"> <p>Either red or black probe will do.</p> </div>  <p>Third wheel bridge</p> <p>Reset pin</p>		<p>(1) Defective contact between the reset lead terminal of the circuit block and the reset contact pin.</p>  <p>Defective contact</p> <p>Reset contact pin</p> <p>Reset lead terminal (Touch the reset lead terminal and the reset contact pin by using tweezers.)</p> <p>(2) Defective contact between the reset pin and the yoke when the crown is pulled out completely.</p> <p>Yoke (Correct the bend or replace the yoke with a new one.)</p>  <p>Defective contact</p> <p>Reset contact pin</p>
CHECK ACCURACY	<p>Check gain and loss of time.</p> <p>(1) Set up the Volt-ohm-meter.</p> <p>(2) Checking Check using the same procedures as in A.</p>  <p>Input indicator</p>	<p>Correct →</p> <p>Incorrect →</p>	<p>Follow the procedures on page 19.</p> <p>Proceed to Time accuracy adjusting</p>
MEASURING CURRENT CONSUMPTION	<p>In case where a frequent battery change is required, a current consumption test is recommended. Use the following procedures:</p> <p>1. Set up the Volt-ohm-meter</p> <ul style="list-style-type: none"> ● Range to be used: DC 0.03 mA ● Set up the condenser of 200 ~ 500 μF as shown in a photo. <p>2. Measurement</p> <ul style="list-style-type: none"> ● Place the battery on the third wheel bridge with its minus side up. Probe Red (+) Battery connection Probe Black (-) Battery surface (-) <p>Be sure to measure with the crown in the pushed in position.</p> 	<p>Less than 2.5 μA →</p> <p>More than 2.5 μA →</p> <p>Remarks: There might be a slight difference in the measured value depending upon the type of volt-ohm-meter. When judging the condition of the circuit block, be sure to take this into consideration.</p>	<p>Proceed to J.</p> <p>Proceed to F. When the coil block is found normal, replace the circuit block with a new one.</p>

All procedures of Disassembling and Reassembling, and Checking and Adjustment are completed.