

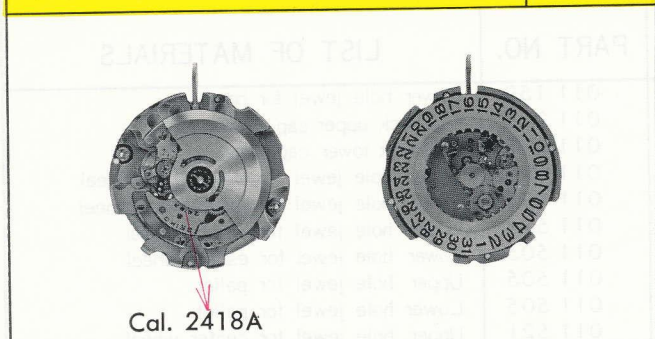

Seiko 2418A Movement Parts (1)

Compiled by EmmyWatch - <https://www.emmywatch.com>











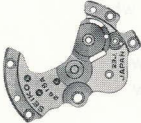



Calibre No. 2418A	Jewels 23j	Style Name AB18A
⇒ Basic Calibre 2406A 23J Catalog No. 24-06-1		



Characteristics

Casing diameter :	24.00 ^φ mm
Maximum height :	4.55 mm
Vibrations per hour :	28,800
Automatic and auxiliary hand winding	
Calendar (date)	
Instant date setting	
"Diashock" Shock Resistant Device	

EMMYWATCH
 VINTAGE RESTORATIONS

 112 241	 122 241	 201 241	 224 241	 225 241	 271 245	 ☆354 243	 373 240
 ☆ 801 241 ☆ 801 247	 803 241	 809 240	 ☆ 884 241	 990 240	 1013 975		

☆⇒ Please see remarks on the next page.
 As for all other parts not shown here, please refer to the basic calibre
 (Cal. No. **2406A** 23J Catalog No. 24-06-1 Red page).

EMILIO

Calibre No. 2418A		Jewels 23j	Style Name	
⇒ Basic Calibre 2406A 23J Catalog No. 24-06-1				
PART NO.	LIST OF MATERIALS	PART NO.	LIST OF MATERIALS	
112 241	Barrel & train-wheel bridge	011 159	Lower hole jewel for barrel	
122 241	Center wheel bridge	011 212	Diashock upper cap jewel	
161 240	Pallet cock	011 212	Diashock lower cap jewel	
171 240	Balance cock	011 422	Upper hole jewel for differential wheel	
191 240	Framework for automatic device	011 422	Lower hole jewel for differential wheel	
201 241	Complete barrel with arbor & mainspring	011 505	Upper hole jewel for escape wheel	
224 241	Center wheel & pinion with cannon pinion	011 505	Lower hole jewel for escape wheel	
225 241	Cannon pinion	011 505	Upper hole jewel for pallet	
231 240	Third wheel & pinion	011 505	Lower hole jewel for pallet	
241 240	Fourth wheel & pinion	011 521	Upper hole jewel for center wheel	
251 240	Escape wheel & pinion	011 521	Lower hole jewel for center wheel	
261 240	Minute wheel	011 541	Upper hole jewel for 4th wheel	
271 245	Hour wheel	011 541	Lower hole jewel for 4th wheel	
282 240	Clutch wheel	011 542	Upper hole jewel for 3rd wheel	
283 240	Winding pinion	011 542	Lower hole jewel for 3rd wheel	
284 240	Crown wheel	012 123	Stud screw	
285 240	Ratchet wheel	012 126	Center wheel bridge screw	
301 110	Jewelled pallet fork & staff	012 126	Minute wheel bridge screw	
310 240	Balance complete with stud	012 275	Bridge screw	
315 240	Balance staff	012 275	Balance cock screw	
331 110	Roller with jewel	012 275	Framework screw for automatic device	
341 240	Regulator	012 297	Crown wheel screw	
345 240	Stud holder	012 421	Transmission wheel screw	
☆354 241	Winding stem	012 763	Pallet cock screw	
☆354 242		012 764	Casing clamp screw	
☆354 243		012 767	Setting lever spring screw	
372 240	Joint stem (movement portion)	012 767	Date jumper guard screw	
373 240	Joint stem (case portion)	012 767	Date driving wheel screw	
381 240	Click	012 767	Screw for setting wheel lever complete	
382 030	Click spring	013 064	Tube for screw of setting wheel lever complete	
383 240	Setting lever	013 065	Tube for yoke	
384 240	Yoke (Clutch lever)	013 834	(Tube for barrel & train-wheel bridge screw)	
387 240	Minute wheel bridge	013 836	Click pin	
388 240	Setting lever spring	013 837	Second reduction wheel pin	
390 240	Setting lever axle	013 975	Eccentric dial pin	
399 003	Casing clamp	014 413	Diashock upper frame	
464 240	Holding ring for setting wheel lever complete	014 414	Diashock lower frame	
481 240	Crown wheel ring	014 415	Diashock hole jewel with frame	
491 180	Dial washer	014 417	Diashock spring	
493 070	Hour wheel ring			
505 240	Transmission wheel			
509 240	Oscillating weight with ball-bearing			
511 240	First reduction wheel			
514 240	Second reduction wheel			
531 240	Differential wheel			
556 240	Date finger			
☆801 241	Date dial			
☆801 247				
802 240	Date driving wheel			
803 241	Setting wheel lever complete			
808 240	Date dial guard			
809 240	Date jumper guard			
810 240	Date jumper			
817 240	Intermediate date wheel			
848 240	First reverser idler			
851 240	Second reverser idler			
☆884 241	Holding ring for dial			
990 240	Date driving wheel holder			
011 157	Lower hole jewel for 1st reverser idler			
011 157	Upper hole jewel for 1st reduction wheel			
011 157	Lower hole jewel for 1st reduction wheel			

☆⇒ Please see remarks on the next page.
 Items in light letters are not shown in photos; those parts are interchangeable with the basic calibre
 (Cal. No. **2406A** 23J Catalog No. 24-06-1 Red page).

Calibre No.

2418A

Jewels

23j

Style Name

⇒ Basic Calibre 2406A 23J Catalog No. 24-06-1

Remarks :

Winding stem — There are three types of winding stems. Select a suitable one by referring to the photographs and the shapes in the lower diagram. _____

- ☆354 241..... a size is **3.80mm** and thread is provided only on the end of the crown portion.
- ☆354 242..... a size is **1.26mm** and thread is provided only on the end of the crown portion.
- ☆354 243..... a size is **7.05mm** and thread is provided only on the end of the crown portion.

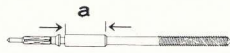

☆354 241

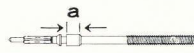

☆354 242



☆354 243

Date dial

- ☆801 241.....Used when both the crown and the date frame are located at **3 o'clock** position.
- ☆801 247.....Used when the crown is located at **3 o'clock** position and the date frame at **6 o'clock** position.

If the date dial is required in any other type, specify ① Cal. No. ② jewels ③ the crown position
④ the date frame position and ⑤ dial No.

Holding ring for dial — The holding ring for dial differs according to the design of the dial. Select the suitable one by the following procedures. _____

- ☆884 241.....Refer to the photograph on the front page and Fig. 1.

When ordering the other part than the above, specify the part number printed in the **12 o'clock** direction of the dial (Refer to Fig. 2).

If the part number of the holding ring for dial is unknown, specify ① Cal. No. ② jewels ③ dial No. and ④ case No.

P.M.W. WATCH
VINTAGE RESTORATIONS

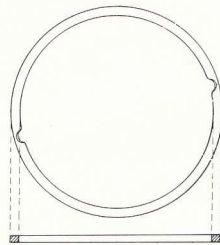

☆884 241

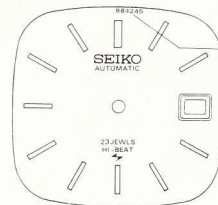

The part number of the holding ring for dial to be used for this dial.