



Seiko 14B Movement Parts (1)

Compiled by EmmyWatch - <https://www.emmywatch.com>

SEIKO

QUARTZ

Cal. 14B

EMMYWATCH
VINTAGE RESTORATIONS

PARTS LIST

Cal. 14B



121 145



131 145



☆224 140



231 140



241 140



261 140



☆271 140



282 140



351 142



383 140



384 140



387 140



388 140



391 140



490 140



491 140



493 160



☆4001 142



4002 140



4146 140



4225 140



4239 140



4242 142



4242 146



4270 140



4446 140



011 541



☆SEIKO SB-DG



012 155



012 156



012 157



012 208



012 374



012 461



012 464



012 777



017 146



017 147



017 148



017 150



017 151



017 160

3/1

Cal. 14B

Characteristics

Casing diameter : 15.1 mm × 13.0 mm
 Maximum height : 2.3 mm without battery
 Jewels : 2 J
 Frequency of quartz crystal oscillator : 32,768 Hz (Hz=Hertz Cycles per second)
 Driving system : Step motor (2 poles)
 Regulation system : Trimmer condenser





PART NO.	PART NAME	PART NO.	PART NAME
121 145	Center wheel bridge	017 146	Tube for center wheel bridge screw
131 145	Third wheel bridge	017 147	Tube for third wheel bridge screw
☆224 140	Center wheel with cannon pinion (3.39 mm)	017 148	Tube for setting lever
☆224 141	Center wheel with cannon pinion (3.49 mm)	017 150	Tube for coil block
231 140	Third wheel & pinion	017 151	Tube for circuit block A
241 140	Fourth wheel & pinion	017 160	Tube for circuit block B
261 140	Minute wheel	☆SEIKO SB-DG }	Silver II oxide battery
☆271 140	Hour wheel (0.85 mm, silver)	☆SEIKO TR621SW }	
☆271 141	Hour wheel (0.95 mm, gold)	☆Toshiba SR621SW }	Silver oxide battery
282 140	Clutch wheel	☆Toshiba W1V }	
351 142	Winding stem (14.10 mm)	☆Maxell SR620SW }	
383 140	Setting lever		
384 140	Yoke (Clutch lever)		
387 140	Minute wheel bridge		
388 140	Setting lever spring		
391 140	Second setting lever		
490 140	Center wheel friction spring		
491 140	Dial washer		
493 160	Hour wheel ring (Thickness 0.03mm, gold)		
493 161	Hour wheel ring (Thickness 0.05 mm, silver)		
493 162	Hour wheel ring (Thickness 0.07 mm, gold)		
☆4001 142	Circuit block		
4002 140	Coil block		
4146 140	Step rotor		
4225 140	Holding ring for battery		
4239 140	Rotor stator		
4242 142	Plus terminal of battery connection A		
4242 146	Plus terminal of battery connection B		
4270 140	Battery connection		
4446 140	Crystal unit cushion		
011 541	Upper hole jewel for step rotor		
011 541	Lower hole jewel for step rotor		
012 155	Dial screw		
012 156	Coil block screw		
012 156	Circuit block screw A		
012 156	Center wheel bridge screw		
012 157	Third wheel bridge screw		
012 208	Setting lever spring screw		
012 374	Screw for holding spring for battery		
012 461	Circuit block screw D		
012 464	Circuit block screw C		
012 777	Minute wheel bridge screw		

☆⇨Please see remarks on the reverse page.
 Part numbers in light letters are not shown in photos.

Cal. 14B

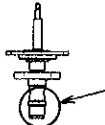
Remarks :

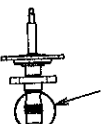
Center wheel with cannon pinion, Hour wheel.
There are two different types as specified below.
Combination

Type	Center wheel with cannon pinion	Hour wheel
a	 ☆224 140	Silver  ☆271 140
b	 ☆224 141	Gold  ☆271 141

Circuit block

☆4001 142.....The parts No. 4001 140 is also used.

Battery

- ☆ SEIKO TR621SW
- ☆ SEIKO SB-DG
- ☆ Toshiba SR621SW
- ☆ Toshiba W1V
- ☆ Maxell SR620SW

The applied battery for this calibre might be added the substitutive in the future.
In that case, please refer to separate **"BATTERIES FOR SEIKO QUARTZ WATCHES"**.

Note that SEIKO battery is marked with **"SEIZAIKEN"** on its (+) side.

EMMYWATCH
VINTAGE RESTORATIONS