



Seiko 0903A Movement Parts (1)

Compiled by EmmyWatch - <https://www.emmywatch.com>

SEIKO

QUARTZ

4004

(Cal. 0903A)

EMMY WATCH
VINTAGE RESTORATIONS

PARTS LIST

Calibre No. <h1 style="text-align: center;">0903A</h1>	Jewels <h1 style="text-align: center;">0j</h1>	Style Name <h1 style="text-align: center;">QUARTZ 4004</h1>
------------------------------------------------------------------	----------------------------------------------------------	-----------------------------------------------------------------------

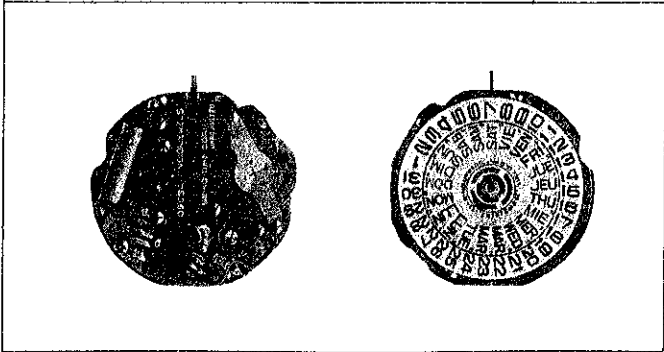

Characteristics

Casing diameter : 27.00 ¹/₄ mm
Maximum height : 5.30 mm
Frequency of quartz crystal oscillator : 32,768 Hz
(Hz = Hertz Cycle per second)
Driving system : Step motor system
Regulation system : Trimmer condenser
Calendar (day & date)
Instant setting device for day & date calendar
Trilingual change-over system for day of week
Second-setting device

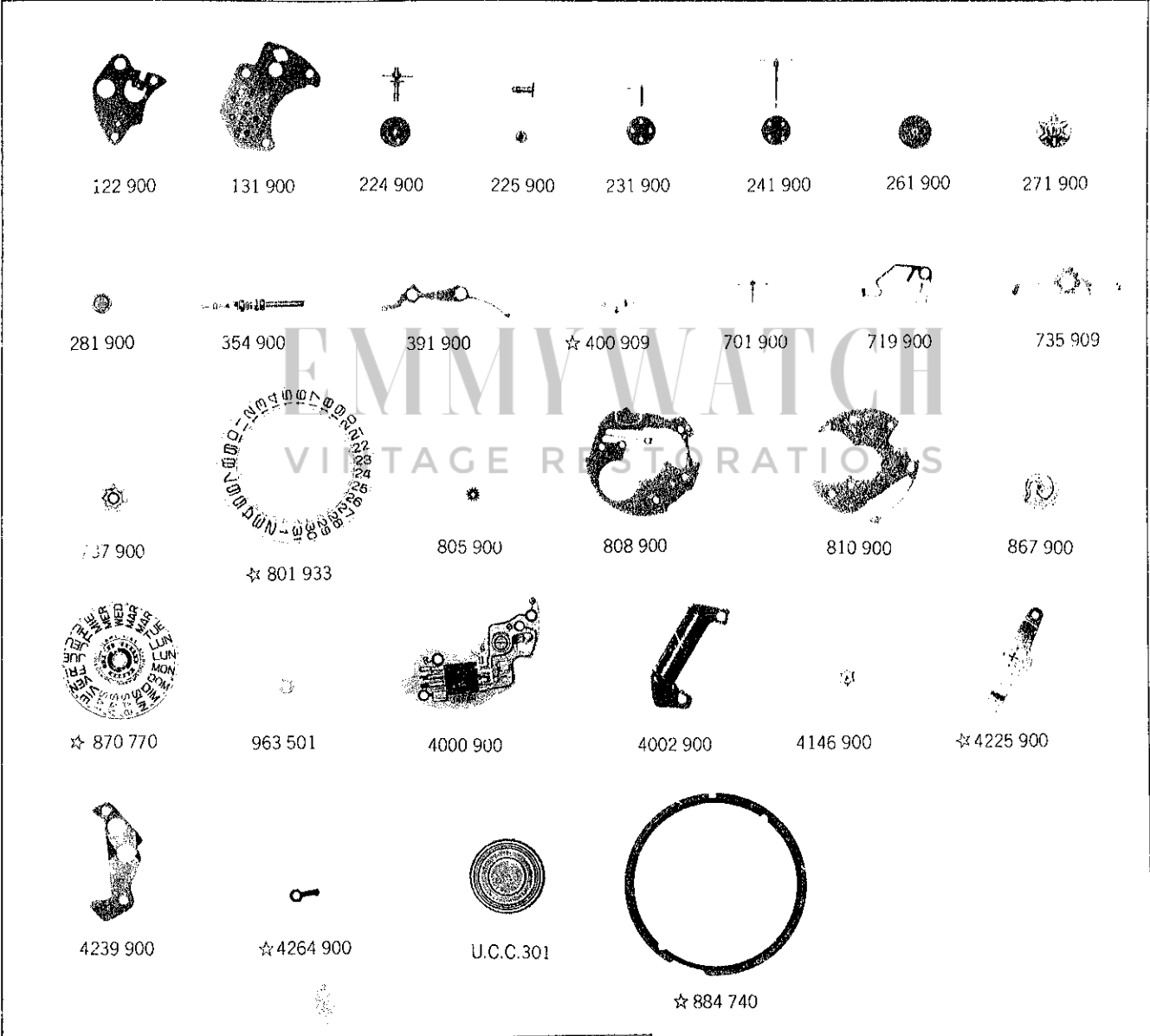

T	T	T	T
022 493	022 494	022 451	022 766

3/1

☆⇨ Please see remarks on the next page.

Calibre No. 0903A	Jewels 0j	Style Name QUARTZ 4004
-----------------------------	---------------------	----------------------------------

PART NO.	PART NAME	PART NO.	PART NAME
122 900	Center wheel bridge	963 501	Snap for day star with dial disk
131 900	Third wheel bridge	4000 900	Circuit block with crystal oscillator & trimmer condenser
224 900	Center wheel & pinion	4002 900	Coil block
225 900	Cannon pinion	4146 900	Step rotor
231 900	Third wheel & pinion	☆4225 900	Holding spring for battery
241 900	Sweep second wheel & pinion	4239 900	Rotor stator
261 900	Minute wheel	☆4264 900	Battery connection for plus terminal
271 900	Hour wheel	U.C.C.301	Silver oxide battery
281 900	Setting wheel	☆884 740	Holding ring for dial
354 900	Winding stem	022 493	Third wheel bridge screw
391 900	Second-setting lever	022 493	Circuit block screw
☆400 909	Lever for unlocking stem	022 493	Coil block screw
701 900	Fifth wheel & pinion	022 494	Center wheel bridge screw
719 900	Day corrector	022 494	Day corrector screw
735 909	Winding stem holder	022 451	Screw for battery connection and holding spring for battery
737 900	Date corrector wheel with winding pinion	022 766	Date dial guard screw
☆801 933	Date dial		
805 900	Intermediate setting wheel		
808 900	Date dial guard		
810 900	Date jumper		
867 900	Day & date driving wheel		
☆870 770	Day star with dial disk (English-French-Spanish)		
☆870 771	Day star with dial disk (English-German-Italian)		
☆870 772	Day star with dial disk (English-Portuguese-Spanish)		
☆870 773	Day star with dial disk (English-Chinese-Roman numerals)		
☆870 774	Day star with dial disk (English-Arabic-Persian)		

Remarks :

Lever for unlocking stem

☆400 909..... Used only for one-piece type case.

Date dial

☆801 933..... Used when both the crown and the date frame are located at **3** o'clock position.

If the date dial is required in any other type, specify (1) Cal. No. (2) the crown position (3) the date frame position and (4) Dial No.

Day star with dial disk

☆870 770 ~ 4..... Used when both the crown and the date frame are located at **3** o'clock position.

If the day star with dial disk is required in any other type, specify the number printed on the disk.

Holding ring for dial

☆884 740..... Used only for one-piece type case.

Holding spring for battery

☆4225 900..... Used only for case without battery hatch.

Battery connection for plus terminal

☆4264 900..... Used only for case with battery hatch.

☆→ Please see remarks.

Part numbers in light letters are not shown in photos.

TECHNICAL GUIDE

CONTENTS

CHARACTERISTICS AND MECHANISM	1
I. SPECIFICATIONS AND FEATURES	3
1. Specifications	3
2. Features	3
II. FUNCTIONING	4
1. Structure of the movement	4
2. Outline of functioning	5
3. Functioning of electric circuit block	5
(1) Circuit block	5
(2) Oscillator regulating device	6
(3) Battery	6
4. Functioning of mechanical portion	7
(1) Step motor	7
(2) Gear train mechanism	8
(3) Setting mechanism	9
(4) Second setting and reset switch	9
(5) Calendar mechanism	10
(6) Case construction	11
III. RESETTING TIME AND CALENDAR	12
1. Resetting time	12
2. Resetting calendar	12
DISASSEMBLING AND REASSEMBLING	13
I. JIGS AND TOOLS FOR REPAIR SERVICING	14
II. USE OF JIGS AND TOOLS	15
1. Quartz tester	15
2. Tester	17
III. DISASSEMBLING, REASSEMBLING, LUBRICATING AND CLEANING	19
1. Disassembling, reassembling and lubricating	19
(1) Disassembling, reassembling and lubricating of calendar mechanism	20
(2) Disassembling, reassembling and lubricating of gear train mechanism	21
2. Cleaning	22

MECHANIC QUARTZ

SEIKO

QUARTZ

CAL.0903A



CHECKING AND ADJUSTMENT	23
CHART	24
A. Check output signal	26
B. Check battery voltage	26
C. Check battery conductivity	28
D. Check circuit block conductivity	26
E. Check circuit block output terminal conductivity	30
F. Check coil block	30
G. Check output signal	32
H. Check second setting lever	32
I. Check gear train condition and calendar mechanism	32
J. Check reset condition	32
K. Check accuracy	32
L. Time accuracy adjusting method	34
Testing time accuracy	35

CHARACTERISTICS AND MECHANISM

EMMYWATCH
VINTAGE RESTORATIONS

The SEIKO Quartz Cal. 0903A is a popular crystal oscillator watch that has been developed on the basis of the SEIKO Quartz group now gaining a fine reputation for its high accuracy.

The elements such as the quartz oscillator, MOS IC, and the step motor which constitute the heart of a quartz oscillator watch have been designed to give optimum performance, in keeping with a watch produced through our advanced research and development. Our new manufacturing techniques have resulted in an advanced-type watch which is extremely simple in construction, easily handled for after-servicing and which is available at an attractive price.

Calibre 0903A

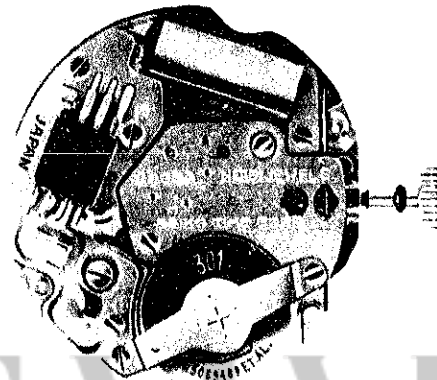

Movement

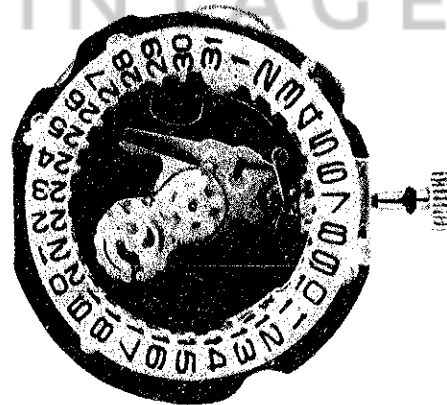

I. SPECIFICATIONS AND FEATURES

The SEIKO QUARTZ 0903A boasts the following specifications and features.

1. Specifications

Item	Cal.	Cal. 0903A
Additional mechanisms		Calendar (day & date) Trilingual change-over system for the day of the week Instant day and date setting Second setting device Electronic circuit reset switch
Crystal oscillator		32,768 Hz (Hz = Hertz cycles per second)
Loss/gain		Loss/gain at normal temperature Annual rate: less than 2.5 minutes (Mean monthly rate: less than 15 seconds.)
Casing diameter		27.0 mmφ
Height		5.3 mm
Operational temperature range		-10°C~+60°C (14°F~140°F)
Driving system		Step motor system
Regulation system		Trimmer condenser
Battery power		Silver oxide battery (U.C.C. 301) Capacity 100 mAH Voltage 1.5V Size 11.6mmφ x 3.44mm

2. Features

- (1) The crystal oscillator generates a stabilized oscillation of 32,768 Hz.
- (2) One-second hand operation system by unique step motor offers high stability.
- (3) Second setting device.
- (4) The instant day and date setting device.
- (5) The trilingual change-over system has been adopted for indicating the day of the week in order to provide more possibilities for the user.
- (6) Low power consumption has succeeded in minimizing the battery size and the movement, giving an attractive appearance to the watch.
- (7) Extensive simplification of the construction permits easy handling and requires no difficult adjustments.
- (8) Time can be easily adjusted by simply turning the trimmer condenser.
- (9) Battery life exceeds one year.

II. FUNCTIONING

1. Structure of the movement

The circular movement consists of a circuit block including a crystal oscillator, coil block, battery, and a mechanical portion of which the main component is a step motor and a

gear train. Since they are formed as individual blocks, each portion can be detached separately, thus simplifying checking and adjustment.

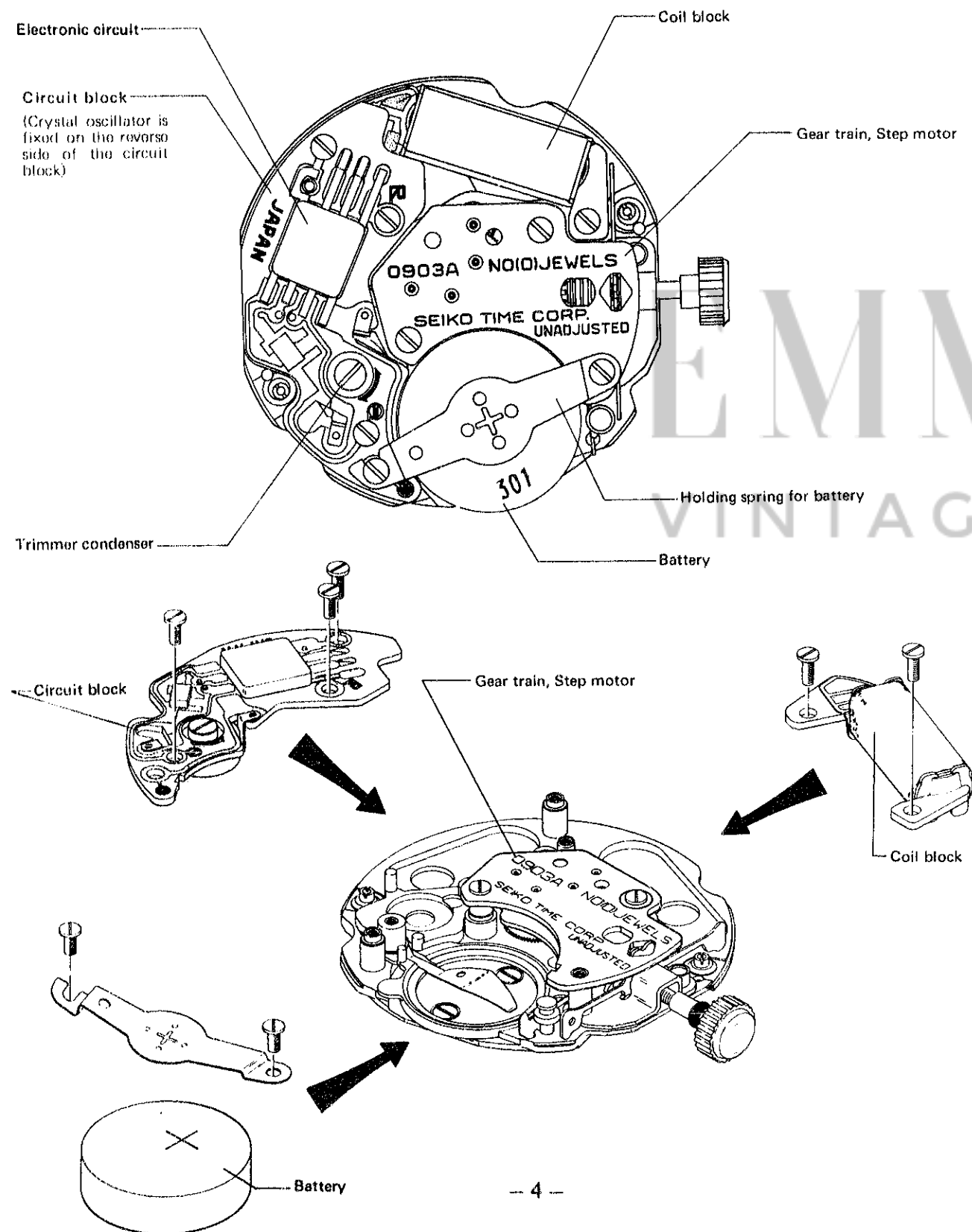

2. Outline of functioning

- (1) The crystal oscillator, built in the crystal unit, oscillates accurately at 32,768 Hz.
- (2) The circuit unit receives the 32,768 Hz oscillations (electronic signals) and converts them into impulses at the rate of one per second, i.e. 1/2, 1/2, 1/2. . . .
- (3) The one-per-second signals are trans-

mitted to coil block, causing step motor to momentarily rotate once every second in 180° increments.

- (4) This rotation is transmitted to gear train thus moving the hands.

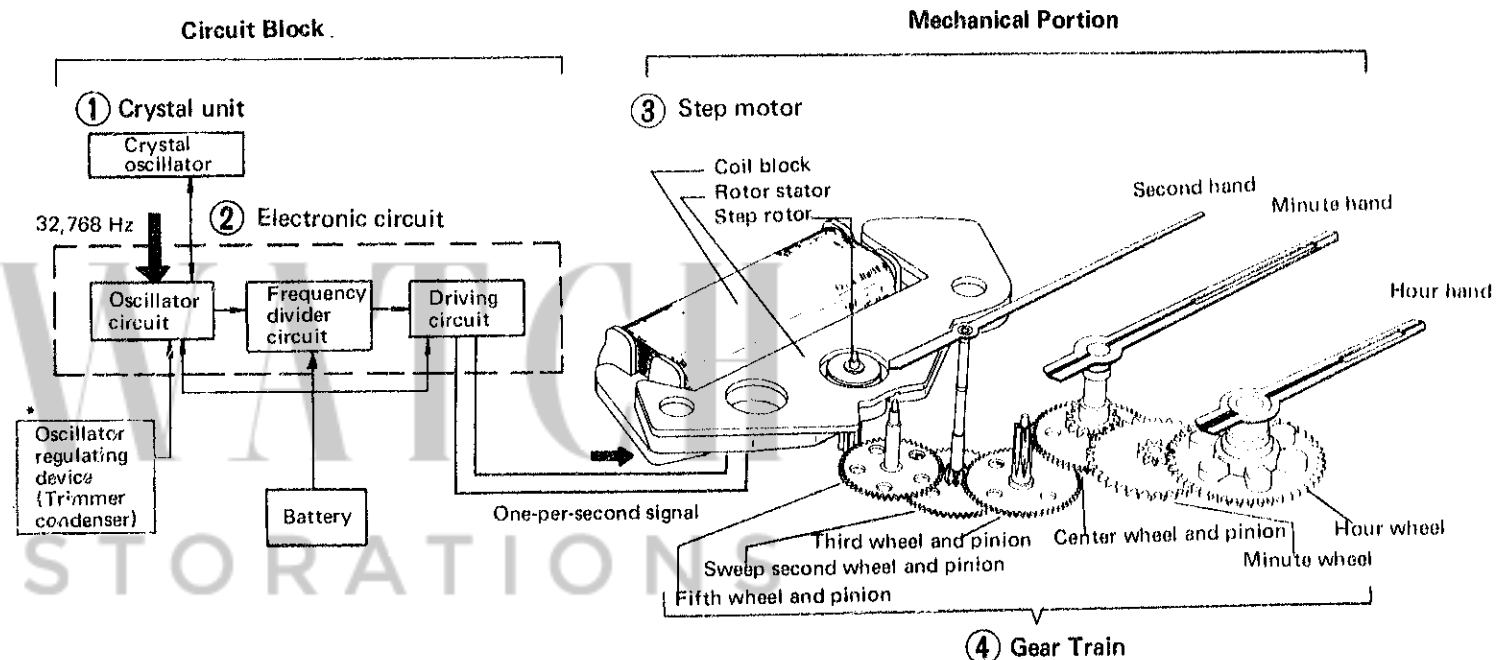

3. Functioning of electronic circuit block

(1) Circuit block

• The crystal oscillator uses the SEIKO ultrasmall tuning fork type and is housed in a flat-type vacuum capsule.

When voltage is supplied from the electronic circuit, the crystal oscillator makes stabilized oscillation accurately at a 32,768 Hz which is the source of the high accuracy obtained in Cal. 0903A watch.

• A MOS IC of high reliability is used in the electronic circuit. The electronic circuit supplies voltage to the crystal oscillator to cause it to oscillate at 32,768 Hz and at the same time it takes out the oscillation in the

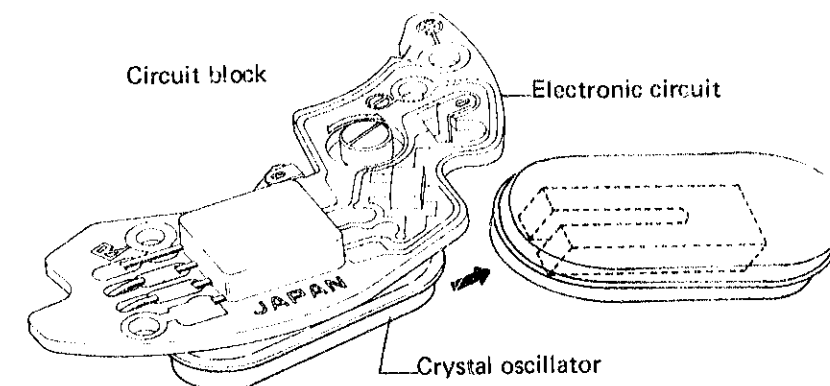

form of an electrical signal. The oscillation of 32,768 Hz is successively divided into 1/2 to finally obtain a signal per second, which is transmitted to the step motor.

(2) Oscillator regulating device

Adjustment of the oscillator of Cal. 0903A watch can be easily made by simply turning the trimmer condenser.

• Function of the Trimmer Condenser

The trimmer condenser consists of a rotor electrode and a stator electrode. Turning the shaft fixed to the rotor changes the overlapped area between the rotor electrode and stator electrode, which in turn changes the capacitance of the trimmer condenser. Turning the trimmer condenser changes its capacitance as shown in the diagram. Time is adjusted by the magnitude of this change.

○ Checking accuracy cannot be made with conventional mechanical wrist-watch testers. It is necessary to use the QUARTZ TESTER.

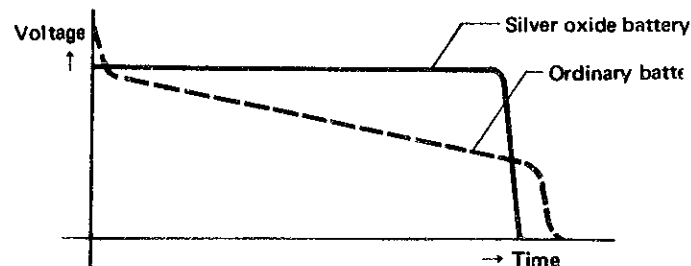
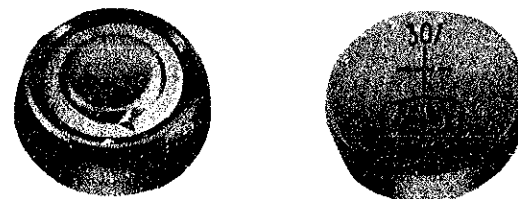
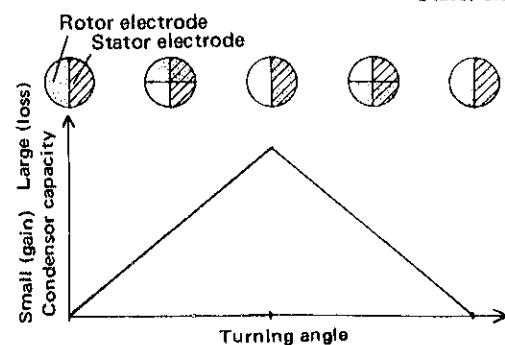
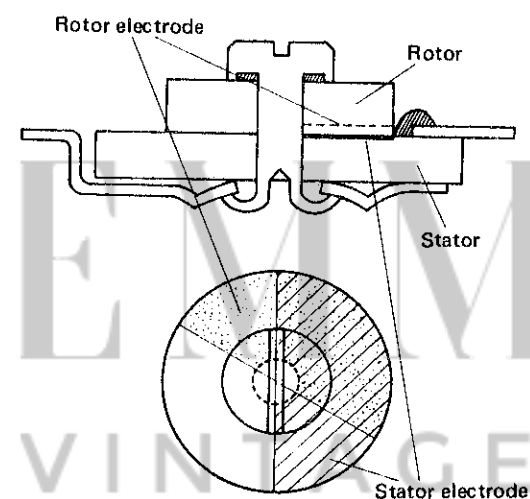
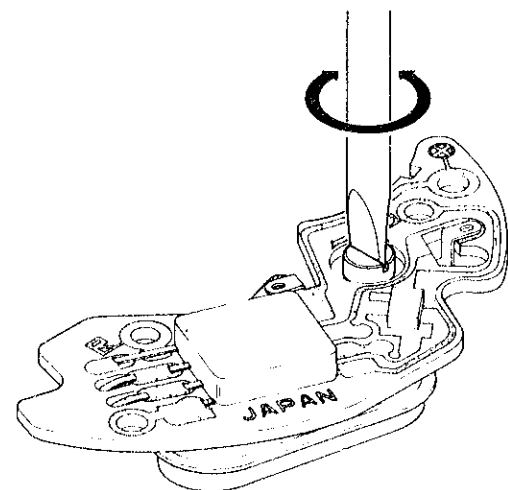

(3) Battery

The electric source, a silver oxide battery (U.C.C. 301) lasts for more than a year.

The battery maintains constant voltage except when it is near the end of its service life at which time the voltage drops sharply. Therefore, when the watch stops or time keeping becomes inaccurate, the first step is to check the battery.

4. Functioning of mechanical portion

(1) Step motor

One of the features of these watches is the SEIKO step motor which changes the vibrations of the crystal oscillator into a rotating motion. The step motor consists of a coil block, two rotor stators and a step rotor. The rotor stators are made of materials having a high conductivity of magnetic force. The step rotor is a circular-shaped permanent magnet having two alternately imposed N and S poles.

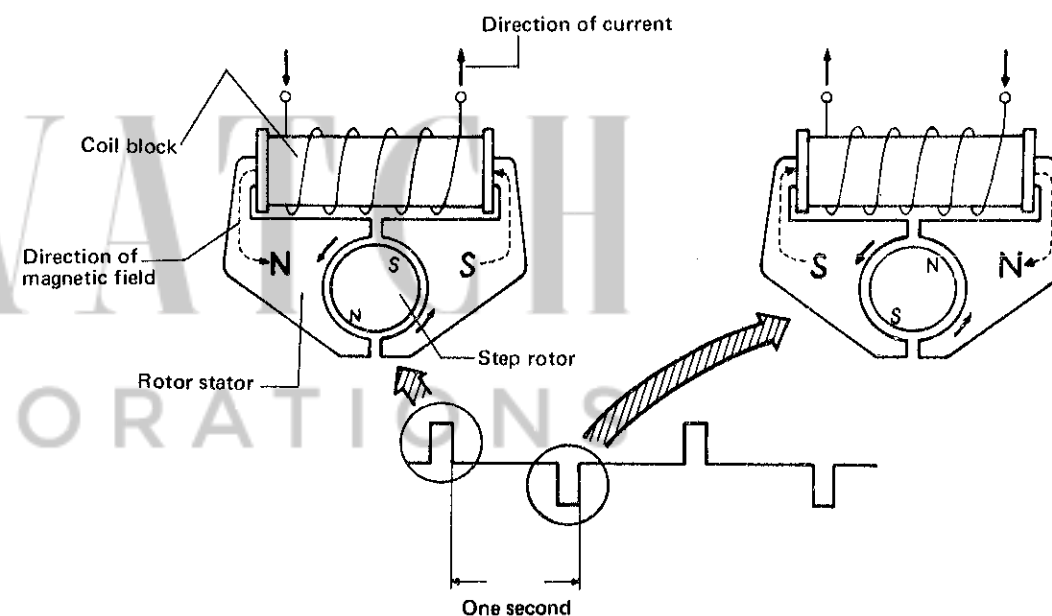
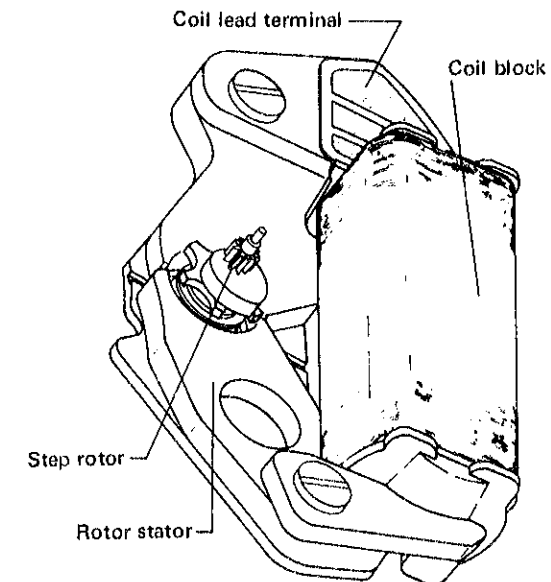

Operational sequence

- (1) Current flows in the coil block
The current, of which the flow direction is changed once every second, is transmitted from the circuit block into the coil block.
- (2) Rotor stators become magnets
When current flows in the coil block, the two rotor stators become magnets and the tip portions become, respectively, N and S poles.
- (3) Step rotor rotations
The N and S poles of the rotor stator tips and the N and S poles of the step rotor alternately repel and attract

causing the step rotor to rotate in 180° increments in a constant direction once every second.

- (4) Rotation of the second hand
Rotation of the step rotor is transmitted to the fifth wheel and pinion which gears with the pinion of the step rotor. The rotation of the fifth wheel and pinion is in turn transmitted to the sweep second wheel and pinion which gears with the pinion of the fifth wheel. The rotation of the fourth wheel and pinion is finally transmitted to move the second hand.

(2) Gear train mechanism

The gear train features a simplified structure which also facilitates servicing. The gear train transmits the torque of the step motor to the indication mechanism.

The rotor rotation of the step motor is transmitted to the fifth wheel, sweep second wheel, third wheel, center wheel, minute wheel and hour wheel.

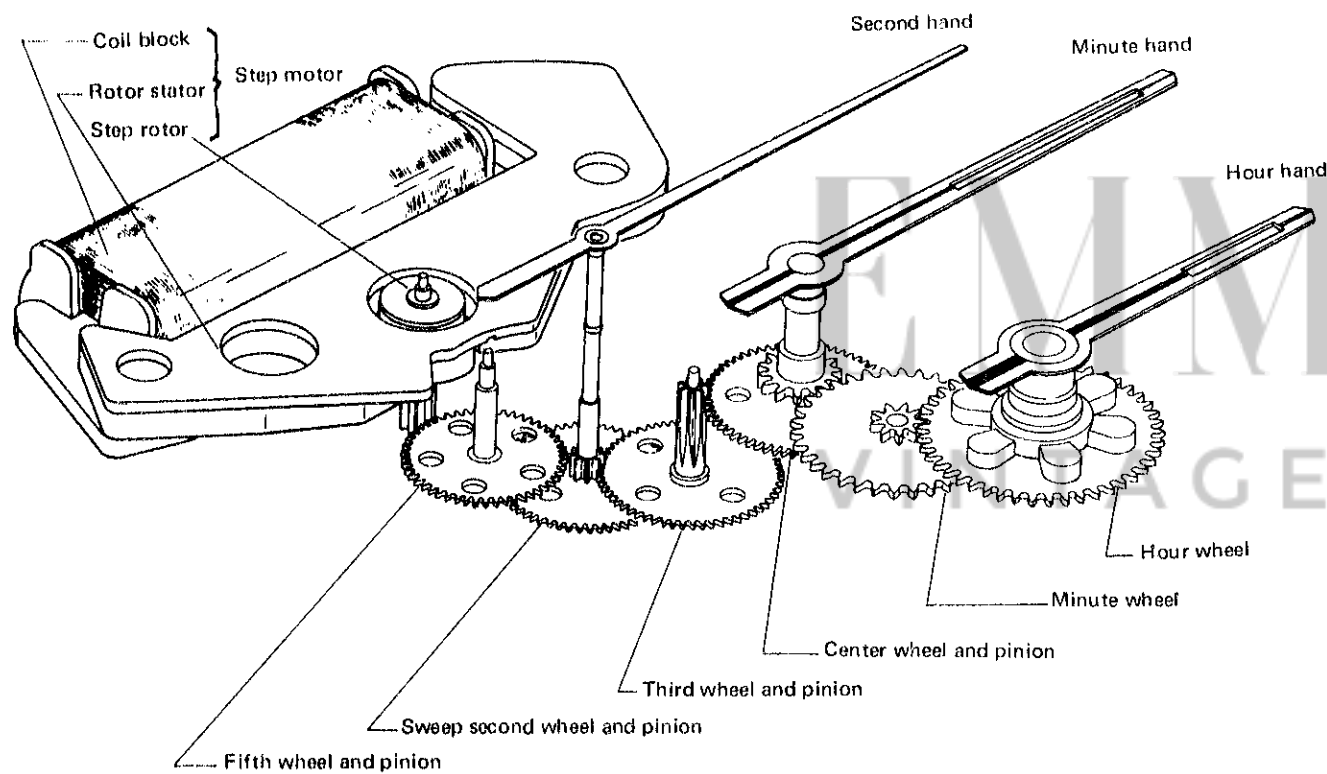

(3) Setting mechanism

The setting mechanism has a simplified structure developed by SEIKO's advanced technology.

- **Normal position**

Free

- **First Click**

The date corrector wheel gears with the date dial and day corrector and the date and day of the week can be adjusted in accordance with the direction in which the crown turns.

- **Second Click**

The time can be set when the pinion of the winding stem gears with the setting wheel. (The day and date corrector wheel does not rotate on this position.)

(4) Second setting and reset switch

A unique second hand setting device and a reset switch are provided for SEIKO Quartz watch Cal. 0903A. This enables "to-the-second" setting of the time.

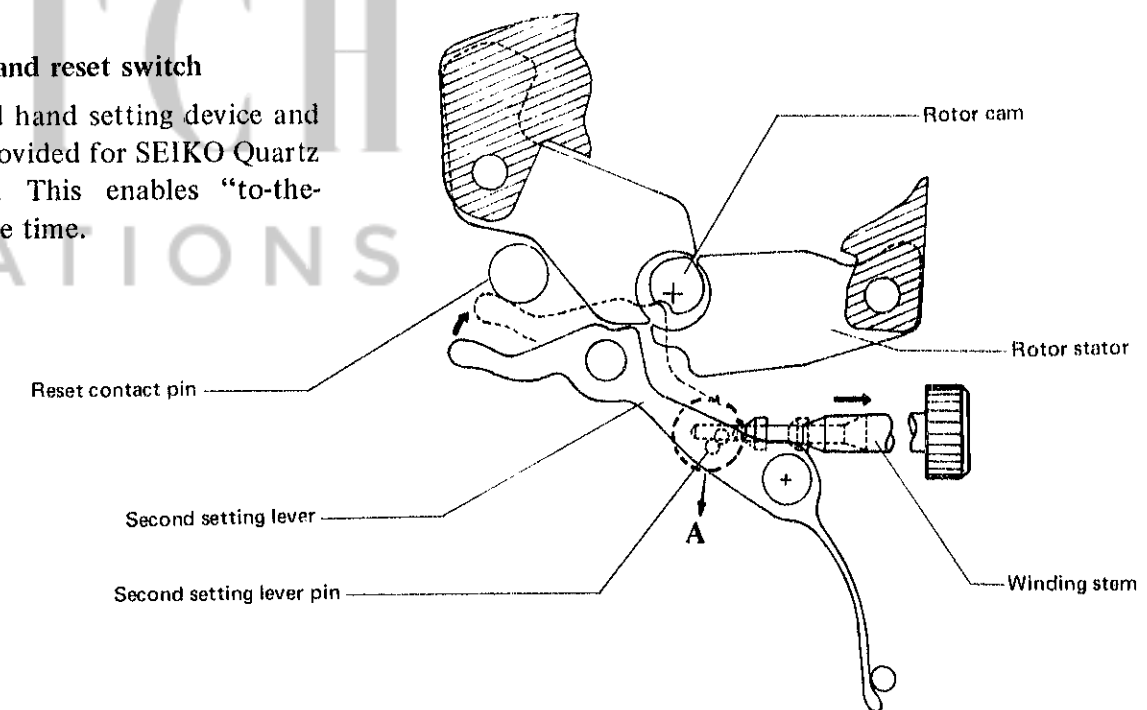
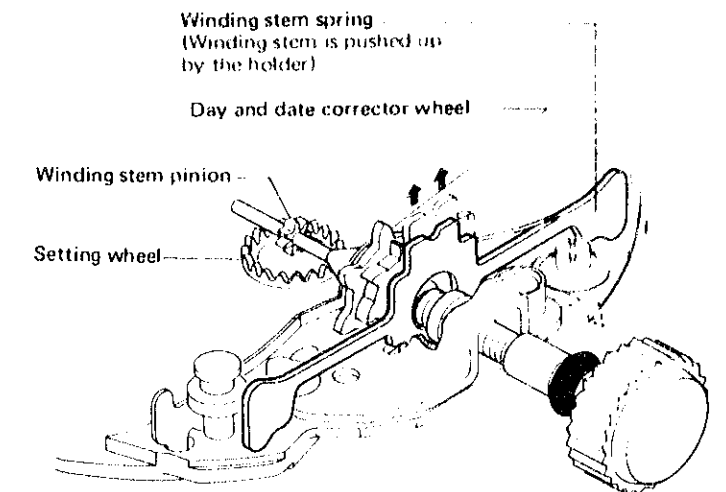

- **Second setting devices**

Pulling the crown out to the second click causes the second setting lever pin to be disconnected from the winding stem (marked A) and the second setting lever regulates the rotor cam. The second hand always stops on an even-numbered second (2, 4, 6, etc.).

- **Reset switch**

When the second hand stops, the second

setting lever is simultaneously disconnected from the winding stem (marked A) and contacts the reset contact pin thus engaging the reset switch. When the reset switch is in the ON position, the watch movement is stopped.

However, the electric current from the battery flows through the crystal oscillator and the electronic circuit. Then the watch is ready to start.

(5) Calendar mechanism

(1) Date and day changes as follows:

- Date 23:00 - 24:00
- Day 24:00 - 03:15

(2) Calendar and hand setting

- Normal position Free
- First click Change of day and date
 - Date change clockwise
 - Day change counterclockwise
 - (Day and date can be changed at any time)

Second click Hand setting, reset switch and second setting

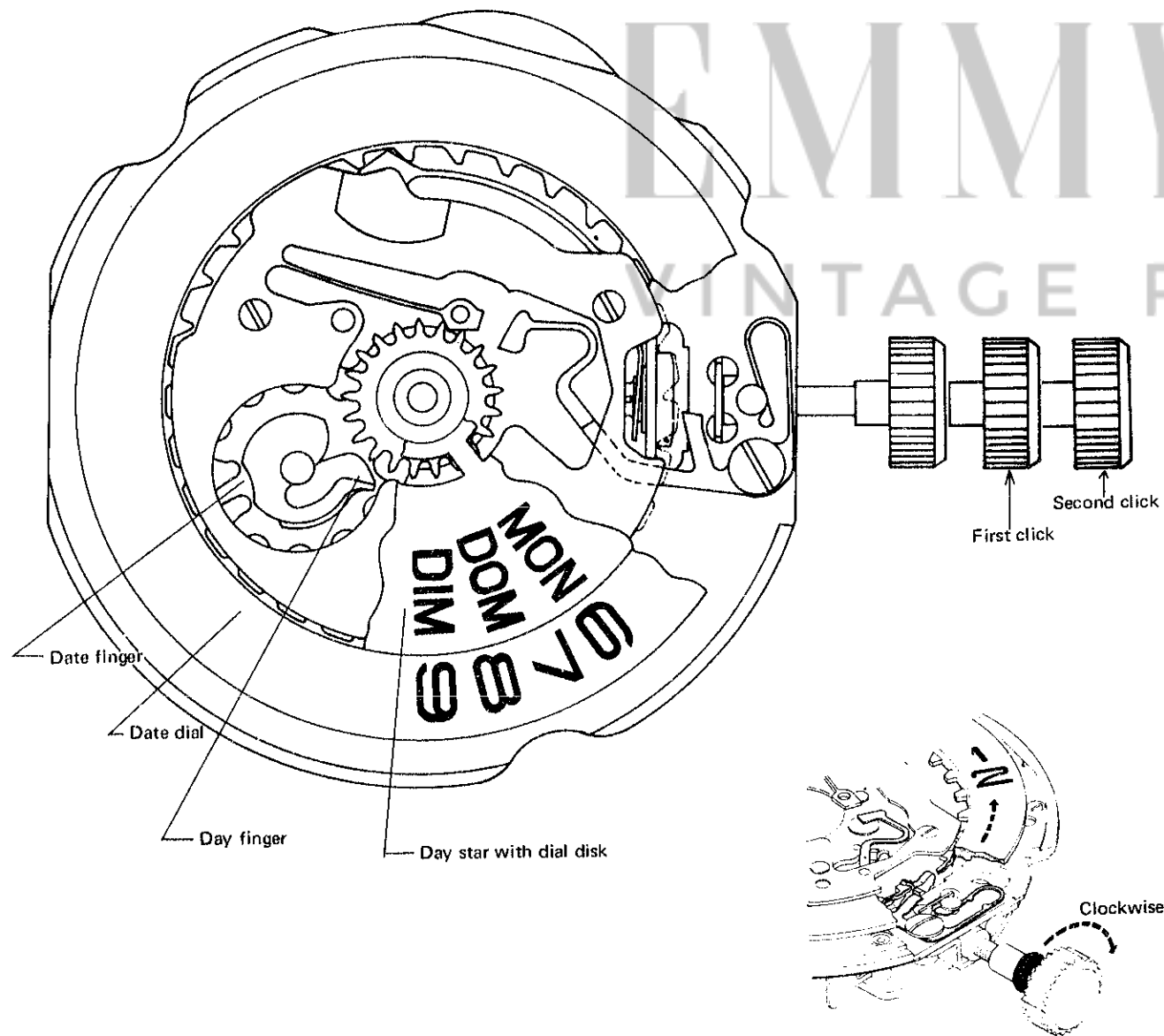

OPERATION

(6) Case construction

Case construction is water resistant. There are two types of caseback construction. One type is provided with the battery hatch on the case back whereas the other is not.

[1] Direction of current flow

Electric current flows from the (+) surface of the battery in the direction shown by the arrow mark (→). The contacting portion of the component parts should therefore be checked for current flow.

- **The watch without the battery hatch**
(Example: Snap type case back construction)

The current flows from the holding spring for battery into the plate.

- **The watch with the battery hatch**
(Example: One-piece type case back construction)

In one type the current flows from the spring for battery connection to the plate through the battery hatch and snap ring. In the other type the current flows from the plus lead terminal to the plate.

[2] Anti-magnetic construction

The dial lower plate and back plate are made of special anti-magnetic metal which completely shields the watch from external magnetic fields.

How to replace the battery

- **The watch without the battery hatch**
(Example: Snap type case back construction)

The battery can be easily replaced by opening the case back, loosening the screw for holding spring for battery, and then shifting the holding spring for battery.

- **The watch with the battery hatch**
(Example: One-piece type case back construction)

The battery can be easily replaced by simply opening the battery hatch.

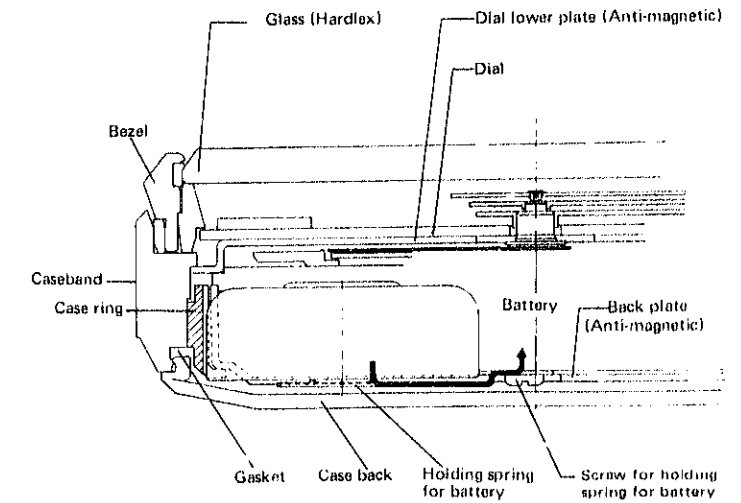

Without the battery hatch
(Example: Snap type case back construction)

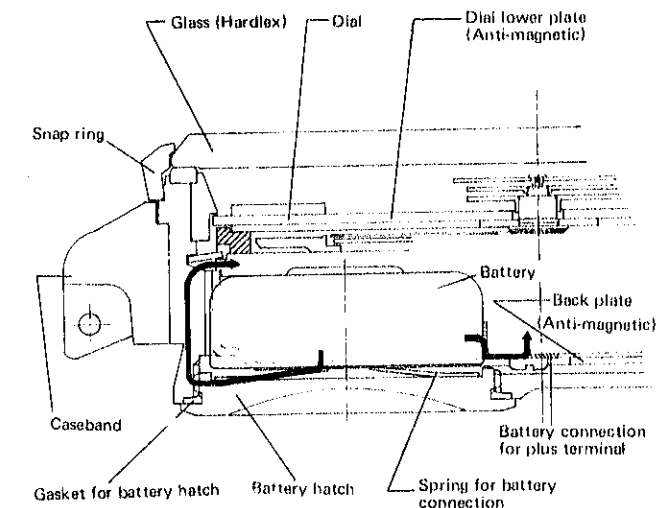

With battery hatch
(Example: One-piece type case back construction)

III. RESETTING TIME AND CALENDAR

HOW TO SET THE TIME AND CALENDAR

1. Resetting time

Pull the crown out to the second click and the second hand stops on an even-numbered second (even-number of the dial) (2, 4, 6, etc.).

Procedures

- (1) When second hand is at 59-second or 60-second position, pull out the crown to the second click and stop the second hand at 0-second position.
- (2) Turn the crown and set the time of hour hand and minute hand. As the rotation of the gear train is transmitted reversely, the time is set accurately by turning the second hand counterclockwise. Since the calendar changes at twelve midnight, first turn the hands until after 12:00 o'clock to confirm if the day changes, then set the time correctly at a.m. or p.m.
- (3) To synchronize with a time signal, push the crown to the innermost position to start the watch. Then the hour, minute and second hand can be set exactly.

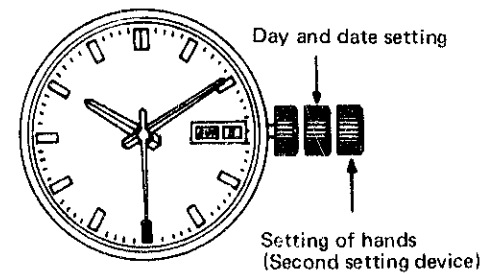

2. Resetting calendar

Pull the crown to the first click.

Turn the crown clockwise and the date will change.

Turn the crown counterclockwise and the day of the week will change.

To make the setting correctly, the day of the week should be set before setting the date.

Select the desired language as three languages appear alternatively when setting the day of the week.

If the setting of the calendar is made when the hour hand is pointing to the time between 9:00 p.m. and 3:30 a.m., sometimes the calendar will not change the next day. Please reset the calendar before or after this time period.

DISASSEMBLING AND REASSEMBLING

I. JIGS AND TOOLS FOR REPAIR SERVICING

For repair servicing, the following SEIKO jigs and tools are necessary.
The following jigs and tools are available at the head office of SEIKO.

- Accuracy tester (Quartz Tester)
- Movement holder
- Movement can
- Holding spring for battery

1. Quartz Tester

Used to check time accuracy (daily rates) and flow of current from circuit block.

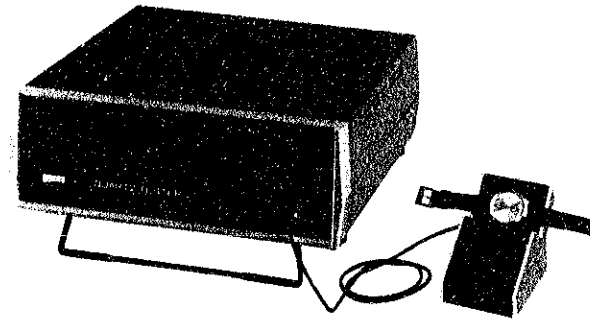

2. Tester

Used for checking battery voltage, measuring resistance and conducting conductivity test.

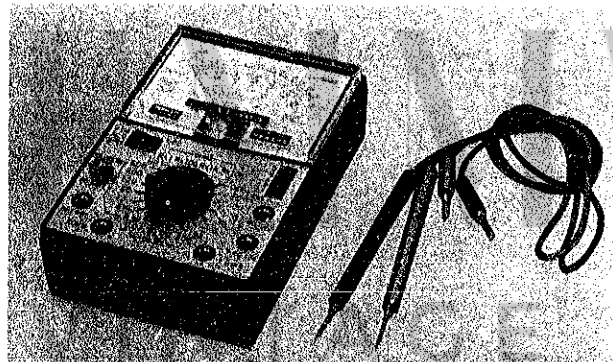

3. Movement holder

Used for disassembling, reassembling, checking and adjusting the movement.

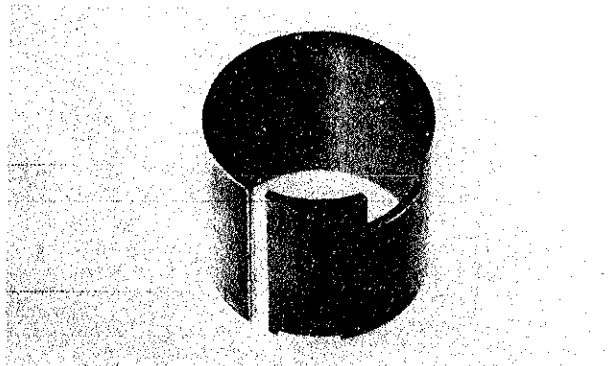

4. Holding spring for battery

Used for securing battery when movement is removed from case or when case back is removed.

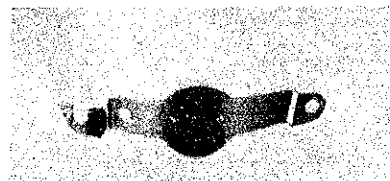

5. Others

- (1) Anti-magnetic tweezers for handling step rotor.
- (2) Nonmetallic tweezers for handling battery.

II. USE OF JIGS AND TOOLS

1. Quartz tester

Used for measuring and checking the following:

- Measuring time accuracy
- Checking flow of current from circuit block

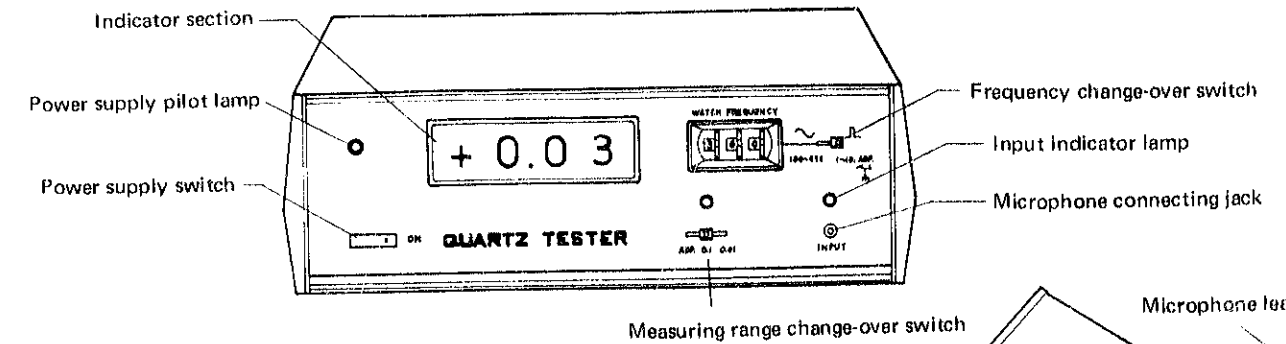

(1) Measuring time accuracy (daily rates)

<Preparation>

- [1] Connect power supply cord to electric outlet.

Thirty minutes are necessary to stabilize tester.

(Connecting power supply cord causes crystal in tester to start oscillation).

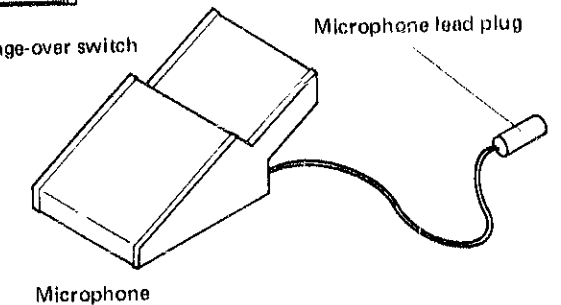

[2] Connect microphone

Insert microphone lead plug in microphone connecting jack of tester.

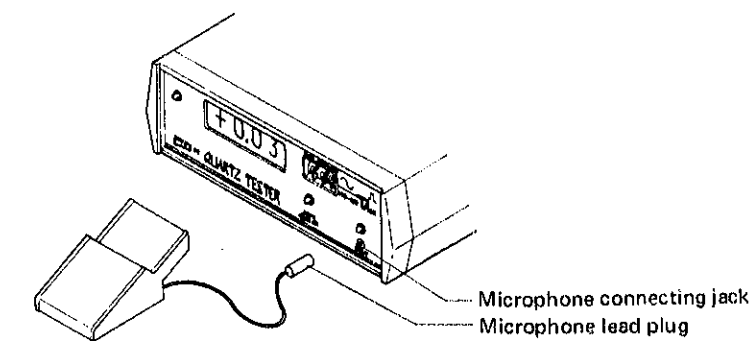

[3] Switch power supply switch to ON position

This will illuminate power supply pilot lamp.

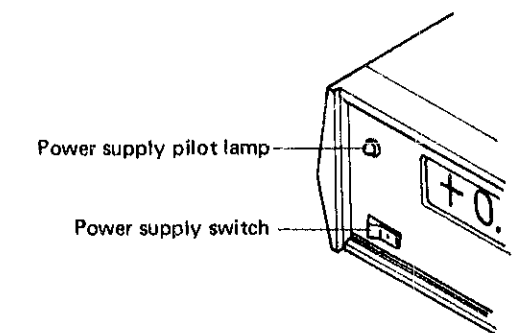

[4] Set frequency change-over switch

[5] Set measuring range change-over switch

- Measuring time is ten seconds

<Measurement>

[6] Place watch on microphone and confirm if input indicator lamp lights at one second intervals.

<Note on positioning watch>

Place watch properly on microphone.

[7] Read daily rate on indicator section.

<Note on reading daily rate>

- When daily rate is excessive there will be no indication.
- The low digit value of 0.01 second sometimes varies; however, this does not indicate a defective condition.
- Read indicated value after second indication.

(2) Follow these procedures when checking flow of normal current from circuit block.

<Preparation>

[1] Connect power supply cord to electric outlet.

After connecting power supply cord, immediate check can be performed without waiting for stabilization of crystal.

[2] Connect microphone.

[3] Switch power supply switch to ON position.

<Checking>

[4] Place watch on microphone.

[5] Confirm if input indicator lamp blinks.

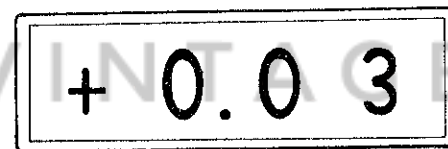
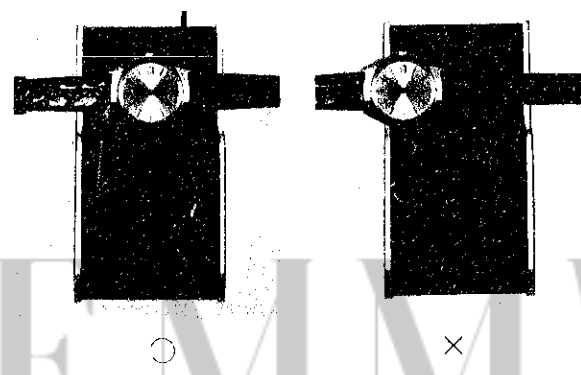
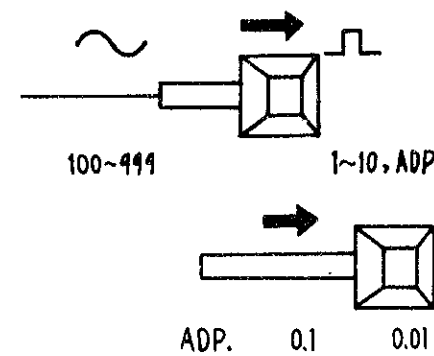

Example: 0.03 second fast

2. Tester

The tester is used to check battery voltage, to measure resistance and to test conductivity.

(1) Measuring battery voltage

[1] Set slide switch to (+) DC and rotary switch to DC3V.

[2] Connect red connector of probe to (+) terminal and black connector to (-) terminal.

[3] Reading

Read voltage at DCV, mA300 scale of scale plate.

Dial indicator shows mA.

Read voltage calculating 1/100

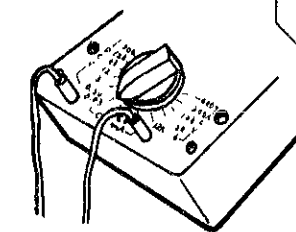
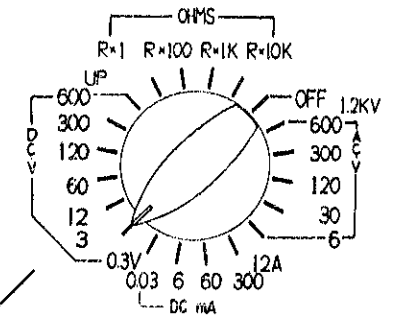
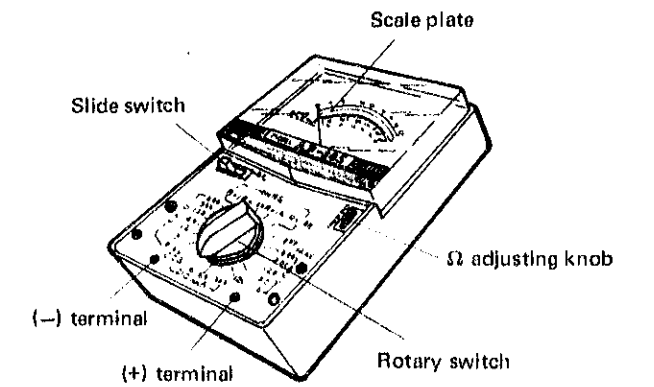

(2) Measuring resistance

[1] Set slide switch to (+) DC and rotary switch to R × 100 of OHMS.

[2] Connect red connector of probe to (+) terminal and connect black connector (-) terminal.

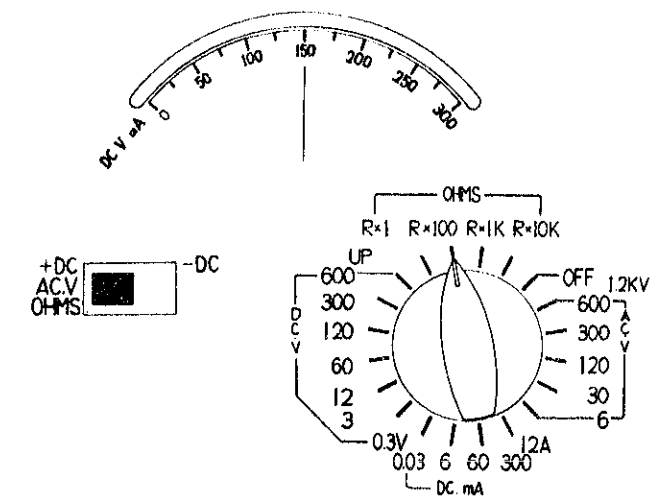

[3] Adjusting 0-ohm

Adjust so that pointer indicates 0Ω by turning Ω adjusting knob while contacting tips of red and black probes.

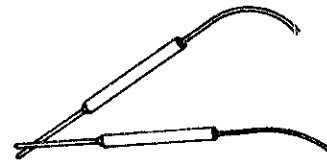

[4] Reading

Read resistance on OHMS scale of scale plate.
Read resistance calculating $\times 100$



(3) Continuity test

[1] Set slide switch to (+) DC and rotary switch to R $\times 1$ of OHMS.

[2] Connect red connector of probe to (+) terminal and connect black connector to (-) terminal

[3] Adjusting 0-ohms

Adjust so that pointer indicates 0Ω by turning Ω adjusting knob while contacting tips of red and black probes.

[4] Reading

Read continuity on OHMS scale of scale plate.

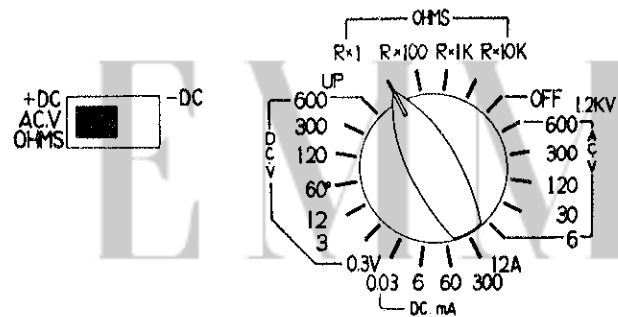

1. Disassembling, reassembling and lubricating

• Disassembling and reassembling

Disassemble watch according to Figs. (1) \rightarrow (32).
Reassemble reversing above procedures: Figs. (32) \rightarrow (1).

Regarding the \blacktriangleright mark in disassembling and reassembling diagrams, refer to items on inspection and adjustment.

• Lubricating

Colored symbols in illustrated figures indicate types of oil, quantities to be applied and lubricating points.

Types of oil

- $\bullet\blacktriangleright$ Moebius A
- $\circ\blacktriangleright$ SEIKO Watch oil S-6

Oil quantity

- $\bullet\bullet\blacktriangleright$ Liberal quantity
- $\bullet\blacktriangleright$ Normal quantity
- \blacktriangleright Extremely small quantity

(1) Disassembling, reassembling and lubricating of calendar mechanism

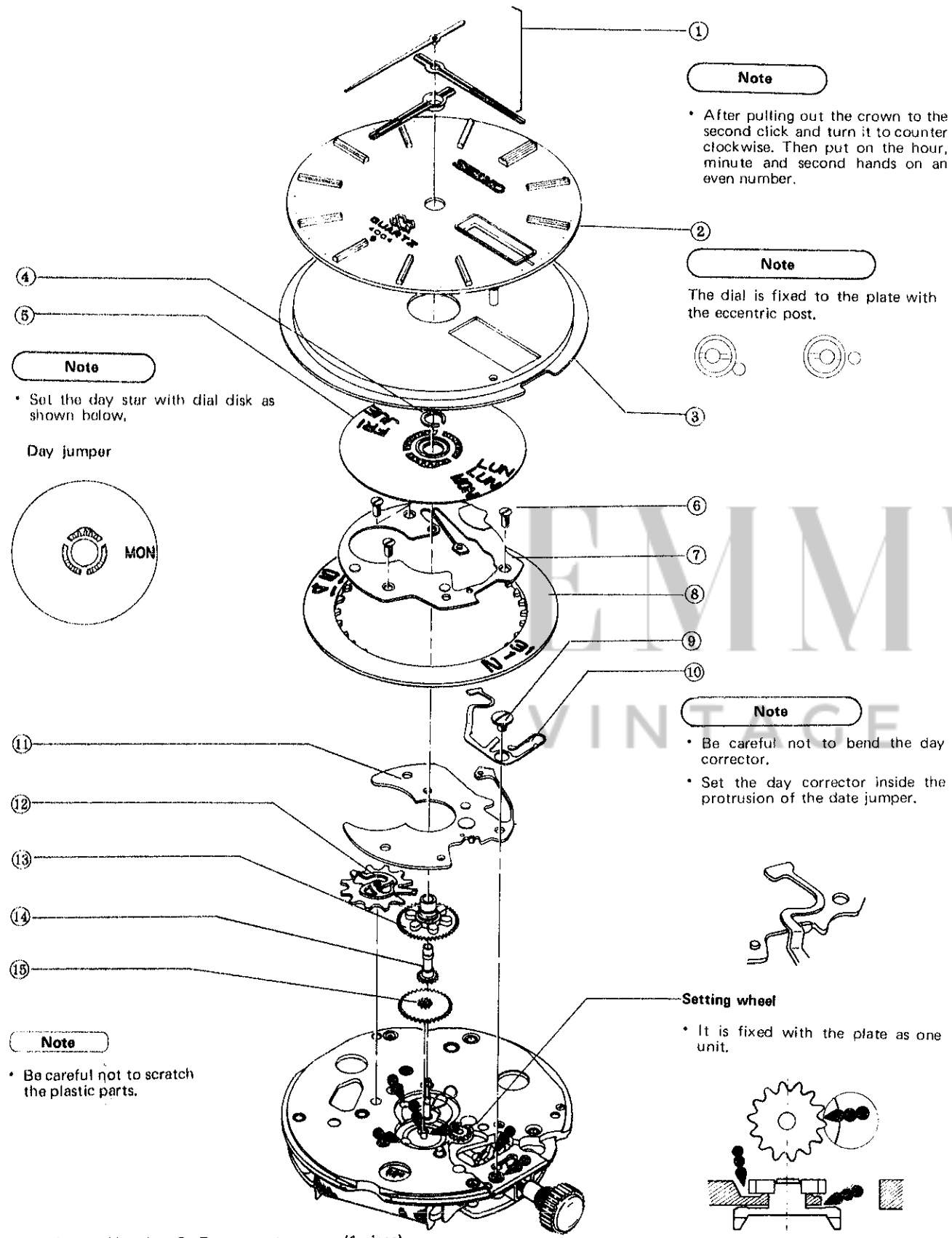

(2) Disassembling, reassembling and lubricating of the gear train mechanism

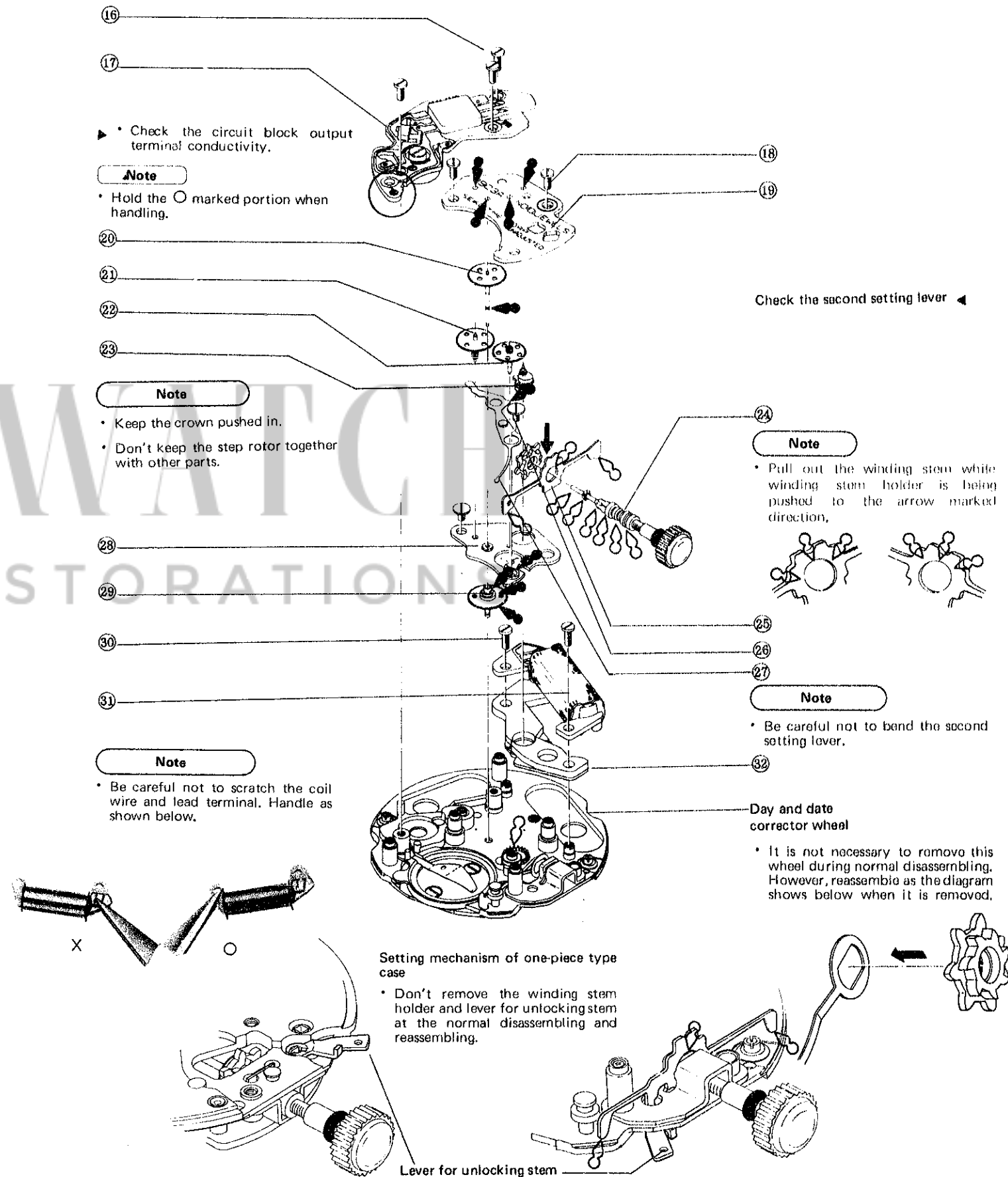



- Parts Name:**
- | | | | |
|-------------------------------------|----------------------------------|---------------------------------------|----------------------------------------|
| 1. Hour, minute and second hands | 9. Day corrector screw (1 piece) | 17. Circuit block | 25. Winding stem holder |
| 2. Dial | 10. Day corrector | 18. Third wheel bridge screw (2 pcs.) | 26. Center wheel bridge screw (2 pcs.) |
| 3. Dial lower plate | 11. Date jumper | 19. Third wheel bridge | 27. Second setting lever |
| 4. Snap for day star with dial disk | 12. Day and date driving wheel | 20. Fourth wheel & pinion | 28. Train-wheel bridge |
| 5. Day star with dial disk | 13. Hour wheel | 21. Third wheel & pinion | 29. Center wheel & pinion |
| 6. Date dial screw (3 pcs.) | 14. Cannon pinion | 22. Fifth wheel and pinion | 30. Coil block screw (2 pcs.) |
| 7. Date dial guard | 15. Minute wheel | 23. Step rotor | 31. Coil block |
| 8. Date dial | 16. Circuit block screw (3 pcs.) | 24. Winding stem | 32. Rotor stator |

2. Cleaning

Since several special parts (electronic, plastic parts, etc.) used in the SEIKO Quartz watch differ from conventional mechanical watches, use the following cleaning methods when cleaning.

How to Clean

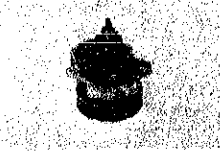
Name of parts	Cleaning	Drying	Solution	Remarks
(1) Circuit block  Coil block 	DO NOT CLEAN			NOTE: Conducting portion <u>ONLY</u> may be cleaned with a cloth moistened with alco- hol or benzine. Dry in <u>COOL</u> air.
(2) Plate  Step rotor 	Rinse or gently scrub with brush	Cool air drying	Benzine	<ul style="list-style-type: none"> • Be careful not to remove connected portions of plate. • Since step rotor is a magnet, use a clean solution. Any foreign matter which cannot be removed by cleaning should be removed with adhesive tape.
(3) Plastic parts	Rinse or gently scrub with brush	Cool air drying	Alcohol	
(4) Parts other than above	Clean with cleaner, rinse and gently scrub with brush.	Cool or hot air drying	Benzine or trichloro- ethylene	

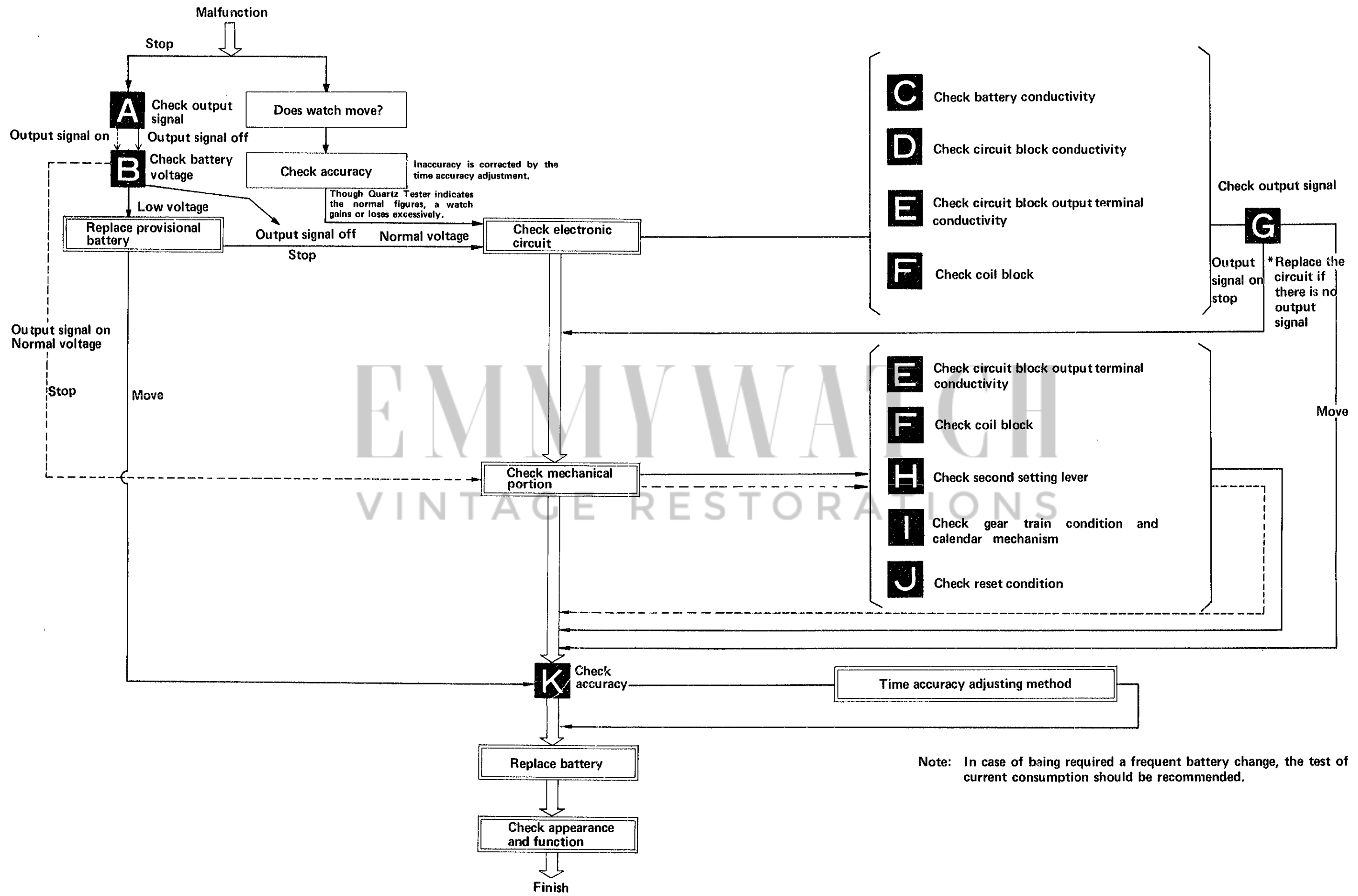

CHECKING AND ADJUSTMENT

I. GUIDE FOR CHECKING AND ADJUSTMENT

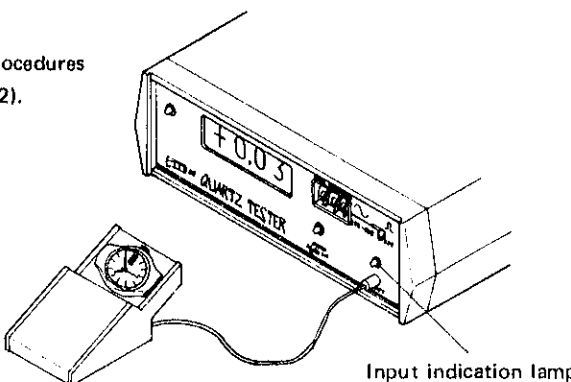
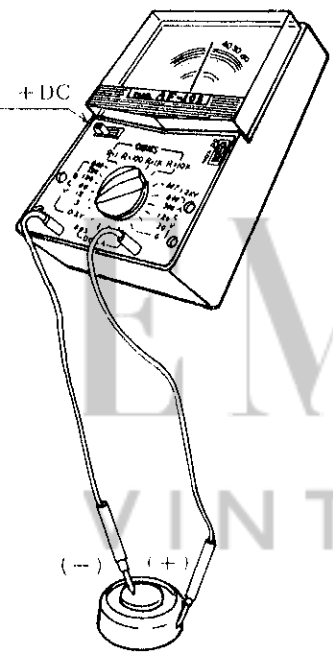
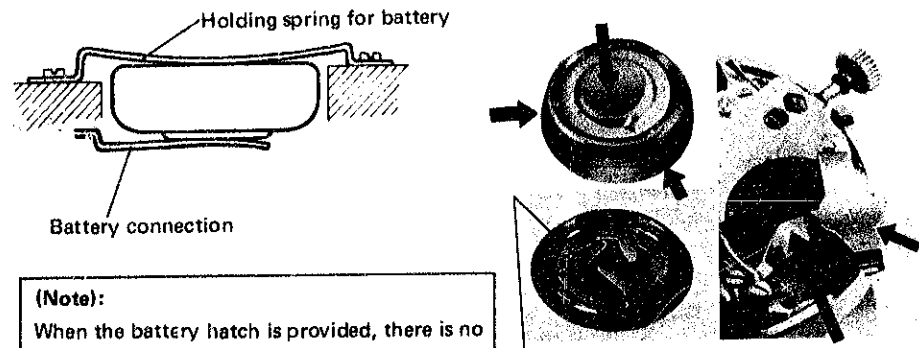

Note: In case of being required a frequent battery change, the test of current consumption should be recommended.

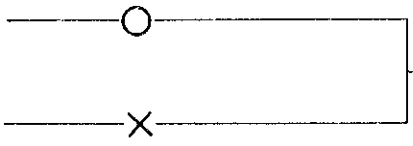
	Procedures	
CHECK OUTPUT SIGNAL	<p>A</p> <p>Check for output signal</p> <ol style="list-style-type: none"> 1. Set Quartz Tester Set Quartz Tester according to procedures described in Handling Methods—(2). 2. Checking Check for output signal (Blinking input indication lamp)  <p style="text-align: right;">Input indication lamp</p> <p>(Note) Push the crown to the normal position.</p>	<p>One-second blinking —</p> <p>No one-second blinking —</p>
CHECK BATTERY VOLTAGE	<p>B</p> <p>Use following procedures to check battery voltage:</p> <ol style="list-style-type: none"> 1. Set tester (Refer to Tester Handling Method) Range to be used DC 3V 2. Measuring <ul style="list-style-type: none"> • Probe Red (+) Battery surface (+) • Probe Black (-) Battery surface (-)  <p style="text-align: right;">+ DC</p> <p style="text-align: right;">(-) (+)</p> <div style="border: 1px solid black; padding: 5px; margin-top: 10px;"> <p>(Note): When handling battery, use non-metallic tweezers or fingercod.</p> </div>	<p>More than 1.5V indicates -</p> <p>Less than 1.5V indicates -</p>
CHECK BATTERY CONDUCTIVITY	<p>C</p> <p>Use following procedures to check if battery current flow to circuit is normal.</p> <ol style="list-style-type: none"> 1. Make sure that the battery holding screw is tightened firmly. Third wheel bridge side Circuit block side 2. Check the connecting point of the battery, holding spring for battery, battery connection and holding spring for battery for stain.  <p style="text-align: right;">Holding spring for battery</p> <p style="text-align: right;">Battery connection</p> <p style="text-align: right;">Spring for battery connection</p> <div style="border: 1px solid black; padding: 5px; margin-top: 10px;"> <p>(Note): When the battery hatch is provided, there is no holding spring for battery.</p> </div>	<p>No loosened screws —</p> <p>Loosened screws —</p> <p>Uncontaminated —</p> <p>Contaminated —</p>

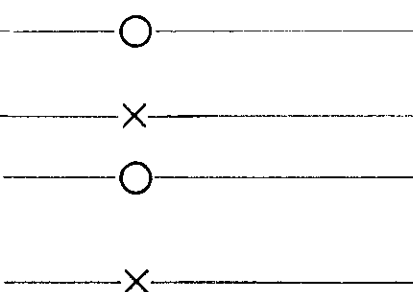
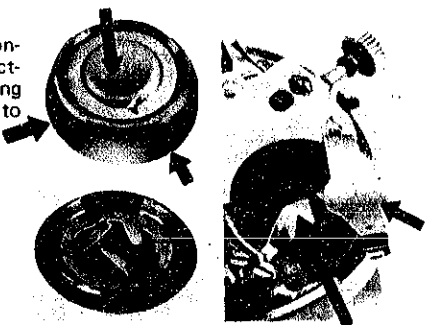
Results	Adjustment and Repair
	<p>Proceed with B</p>
	<p>In case of ○ of A check mechanical portion</p> <p>In case of X of A check electronic circuit</p> <div style="border: 1px solid black; padding: 5px; margin-top: 5px;"> <p>Replace with provisional battery.</p> </div> <p>• If it operates after battery replacement, proceed to accuracy test K</p> <p>• If it does not operate after battery replacement, proceed to electronic circuit test.</p>
	<p>Proceed with C 2.</p> <p>• Retighten screws</p> <p>Proceed with C 3.</p> <p>• Carefully wipe off any contamination on battery contacting surfaces, holding spring and connections. (Refer to Cleaning Method).</p> <div style="border: 1px solid black; padding: 5px; margin-top: 5px;"> <p>Note: Be careful not to damage any connection for battery.</p> </div> 

Procedures

1. Check the circuit output terminal for short circuit.

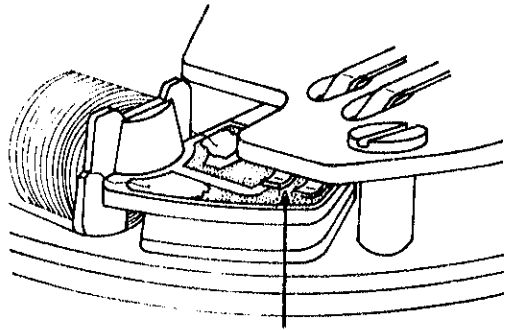

Short circuit is resulted from the output terminal deformation.

2. Check the rigid contact with the coil lead terminal.

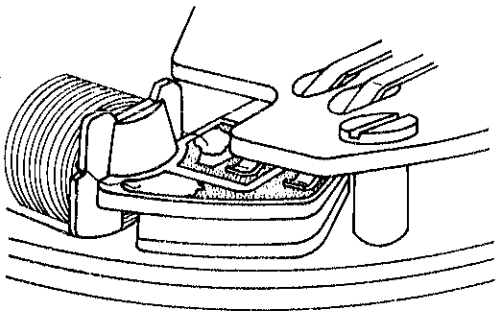

3. Remove circuit block and check for any contamination on the output terminal and coil lead terminal.

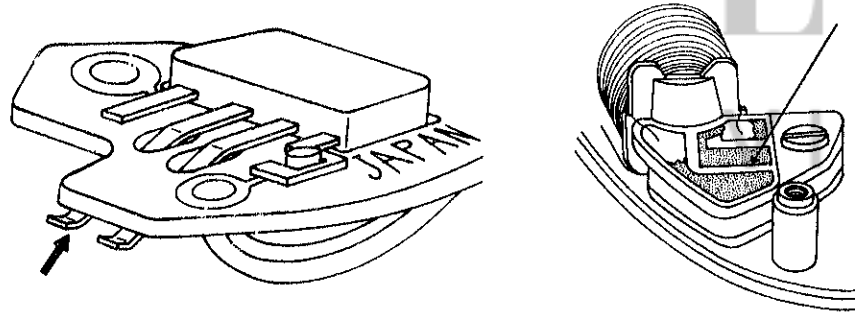

Normal condition ———

Short circuit ———

Normal condition ———

The output terminal is not connected with the coil lead terminal.

Uncontaminated ———

Contaminated ———

Remove circuit block to check the breaking of coil wire and short circuit.

• Set tester

Range at OHMS R x 100

1. Touch probes of tester to two terminals (a and b) of coil, respectively.

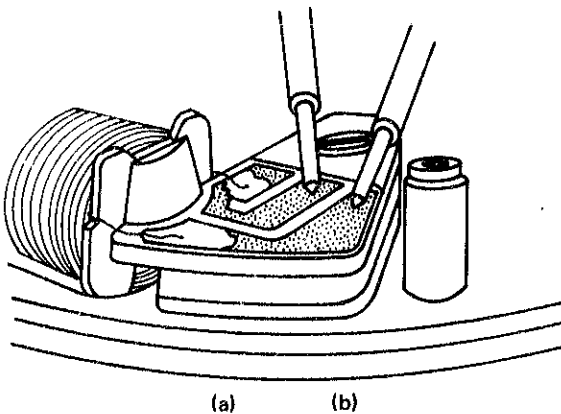

1.5 KΩ—3.5 KΩ ———

Less than 1.5 KΩ ———

More than 3.5 KΩ ———

(Note):

Be careful to avoid breaking coil wires. Hold coil block as shown in photo.

Results

○ ———→

× ———→

○ ———→

× ———→

○ ———→

× ———→

○ ———→

Short circuit ———→
Broken wire ———→



Adjustment and Repair

Proceed with **E** 2.

- Correct the bend of terminals with tweezers.

Proceed with **E** 3.

- Correct the bend of circuit output terminals with tweezers.

Proceed with **F**

Wipe off the contamination on terminal.



In case of **Checking Electronic Circuit** proceed with **G**

In case of **Checking Mechanical Portion** proceed with **H**

- Replace coil block
Unscrew the coil block screws (2 pcs.) with third wheel bridge.
The coil is removed by reversing the main plate.

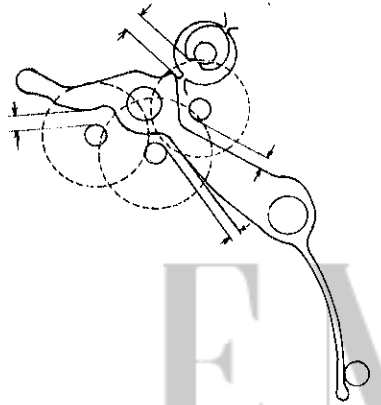
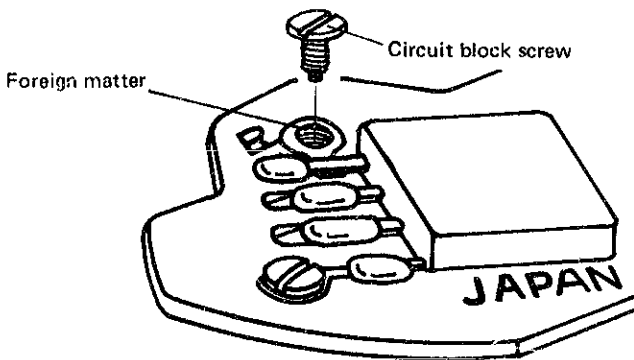

		Procedures	
G CHECK OUTPUT SIGNAL		Check the output signal. 1. Set Quartz Tester 2. Check	Check with the same procedures of A One-second blinking _____ No one-second blinking _____
		Check if the second setting lever is making contact with the gear train. • When the crown is at the normal position and first click. 1. Check to be sure that the second setting lever, rotor cum, third wheel and pinion, fourth wheel and pinion and fifth wheel and pinion are turning horizontally and that they are flush with each other. (Check the clearance at the arrow marked portion.) 2. Check to be sure that the second setting lever moves exactly when the crown is pulled out to the second click.	Not attach _____ Attach _____ Between reset contact pin and second setting lever. No clearance _____ Clearance _____
I CHECK SECOND SETTING LEVER			
J CHECK RESET CONDITION		• Check the reset condition after the circuit block is assembled. 1. Check if the second hand stops exactly on the second click and if it starts promptly one second after the crown is returned. 2. Check the tightness of the circuit block screw. 3. Check for disconnection and foreign matter on the reset circuit block on the reset and circuit block.	Stops completely and starts moving after one second. _____ Does not stop or move irregularly. _____ No loose screws _____ Loose screws _____ No disconnection and foreign matter _____ Disconnection and foreign matter _____
			
K CHECK ACCU- RACY		Check gain and loss of time accuracy. 1. Set Quartz Tester (Refer to Quartz Tester Handling Method)	Normal _____ Defective _____

Results	Adjustment and Repair
Move → Stop → X →	Proceed with K Check mechanical portion H Replace the circuit block.
○ → X →	Proceed with H 2. Repair the defective portion.
○ → X →	Proceed with I • Lubricate. • Check the shape of the second setting lever spring, and correct if bent.
○ → X →	Proceed with J • Repair the defective portion.
○ → X →	Proceed with K Proceed with J 2. Proceed with J 3. Retighten the screws. Proceed with K
○ → X →	• Replace the circuit block if disconnected, and wipe it clean if dirty.
○ → X →	<div style="border: 1px solid black; padding: 2px; display: inline-block;">Replace the battery</div> <div style="border: 1px solid black; padding: 2px; display: inline-block;">Adjust time accuracy</div>

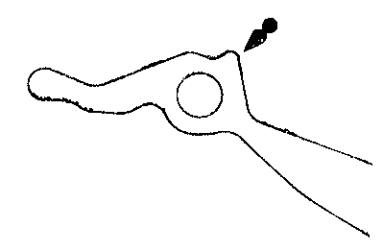

Time accuracy is adjusted by turning the trimmer condenser.

The watch gains or loses according to the direction in which the trimmer condenser is turned. Adjustment should therefore be made after ascertaining by the Quartz Tester whether the watch tends to gain or lose.

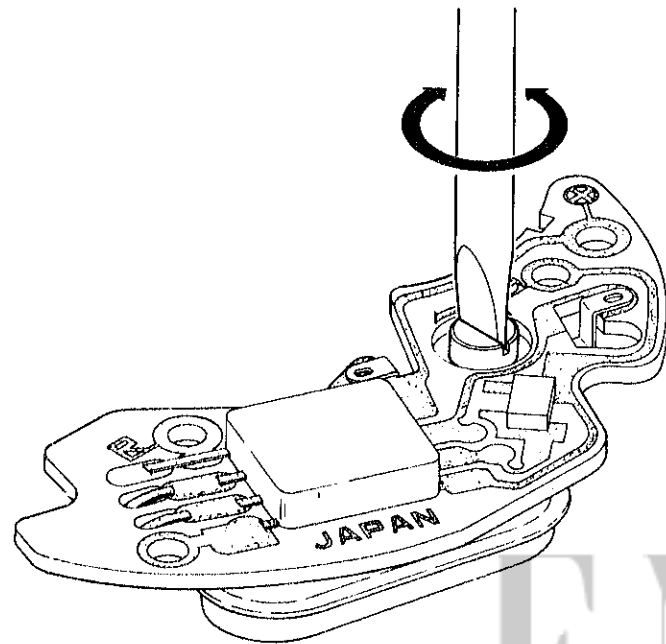

- Note for handling of Trimmer Condenser.
Avoid excessive depressing and turning the trimmer condenser.

EMMY WATCH
VINTAGE RESTORATIONS

TESTING TIME ACCURACY

The time accuracy test is made with the Quartz tester. When testing with the Quartz tester, there will be a slight difference between the tested time and actual time accuracy as the room temperature and the watch temperature on the wrist are not the same.

For example, when the room temperature is 25°C, the Quartz tester will show plus figures, because the watch is so designed that it maintains high accuracy at the temperature on the wrist which is generally 30°C.

The watch's accuracy is less than 15 seconds per month, or this can be calculated less than 0.5 seconds per day. Therefore, even when the tester indicates an excess of plus 0.5 seconds, because the actual time accuracy will be slightly less than that indicated by the tester when worn on the wrist, it will be within the average tolerance.

Quartz watches displayed in illuminated show cases will have a higher temperature. When tested with the Quartz tester, the figures may not be stable. Therefore, it should be read after the temperature of the watch becomes stabilized.

