



Ronda 502,503,505,512,513 Movement Parts (1)

Compiled by EmmyWatch - <https://www.emmywatch.com>



10 1/2'''

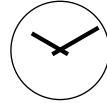

502

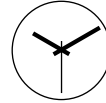

503

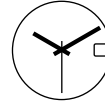

505



507



11 1/2'''

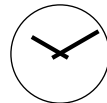

512

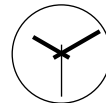

513

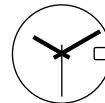

515



517

1. Werkdimensionen

1. Dimensions des mouvements

1. Movement dimensions

Kaliber	Ø Total	Ø Werksitz	Werkhöhe	Höhe Batterie	Höhe Stellwelle	Höhe Werkauflage
Calibre	Ø Total	Ø Encageage	Hauteur mouvement	Hauteur pile	Hauteur tige	Hauteur filet
Caliber	Ø Total	Ø Case fitting	Movement height	Height of battery	Height of stem	Movement rest
Einh./ Unité/ Unit	mm	mm	mm	mm	mm	mm
502-507	23,90	23,30	3,00	3,25	1,50	0,80
512-517	26,20	25,60	3,00	3,25	1,50	0,80
Stellwellingwinde/ Filetage de la tige/ Stem thread: Ø0,90 mm				Weg/ Chemin/ Length of travel: 1,00 mm		

2. Funktionen

2. Fonctions

2. Functions

Kaliber	Stellwellenpos.	Funktionen
Calibre	Pos. de tige	Fonctions
Caliber	Stem position	Functions
502-503,	1	Normale Position / Position normale / Running position
503S		Zeiger stellen, Sekunden-Stopp mit Unterbruch der Motorimpulse
512-513,	2	Mise à l'heure, stop-seconde avec interruption des impulsions moteur
513S		Hand setting, stop-second with interruption of motor pulses
	1	Normale Position / Position normale / Running position
505, 515	2	Datum- + Wochentagkorrektur / Correction de la date et du jour / Date + day correction
505S, 515S		Zeiger stellen, Sekunden-Stopp mit Unterbruch der Motorimpulse
507, 517	3	Mise à l'heure, stop-seconde avec interruption des impulsions moteur
		Hand setting, stop-second with interruption of motor pulses
505-517		Hinweis: für Kalender/Wochentag-Schnellkorrektur: siehe Seite 6 Correction rapide du calendrier/jour: voir page 6 Quick change date/weekday function: see page 6

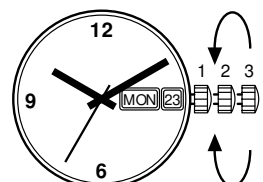
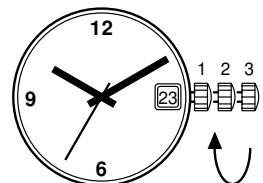

Werkaufbau

Assemblage

Assembling

10 1/2''' 502, 503/503S, 505/505S, 507
 11 1/2''' 512, 513/513S, 515/515S, 517

10 1/2''' 502, 503/503S
 11 1/2''' 512, 513/513S

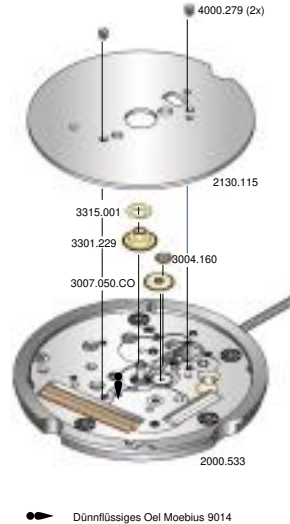
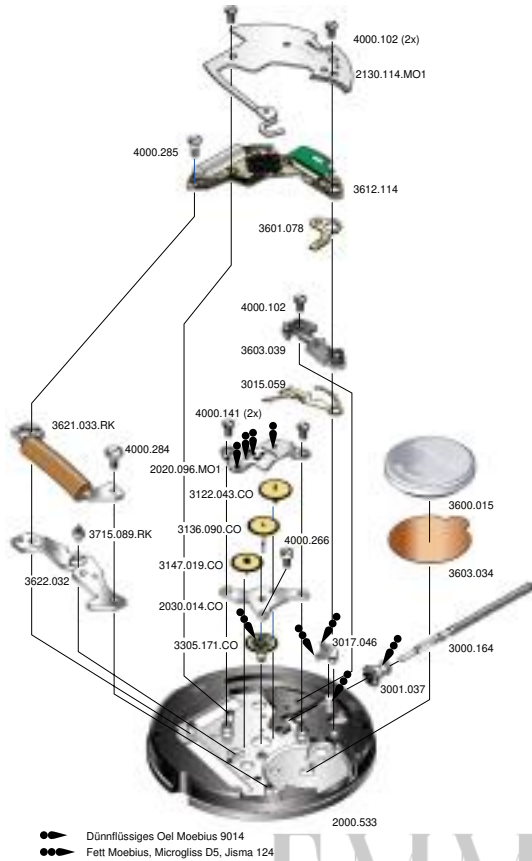

••• Dünflüssiges Öl Moebius 9014
 ••• Fett Moebius, Microgliss D5, Jisma 124

••• Dünflüssiges Öl Moebius 9014

Plan No.	Bestandteile	Fournitures	Spare Parts
2000.533	Werkplatte	Platine	Main plate
2020.096.MO1	Räderwerkbrücke	Pont rouage	Train w. bridge
2030.014.CO	Zentrumbrücke	Pont centre	Centrebridge
2130.114.MO1	Modul-Abdeckp.	Couvre module	Module cover pl.
3000.164	Stellwelle	Tige	Stem
3001.037	Kupplungstrieb	Pignon coulant	Sliding pinion
3015.059	Kuppl.-triebhebel	Bascule	Yoke
3017.046	Winkelhebel	Tirette	Setting lever
3122.043.CO	Kleinbodenrad	Rouemoyenne	Third wheel
3136.090.CO	Sekundenrad	Rouessecondes	Second-wheel
3147.019.CO	Zwischenrad	Roue interméd.	Intermed. wheel
3305.171.CO	Minutenrohr	Chaussée	Cannon pinion
3600.015	Batterie	Pile	Battery
3601.078	Batterie-Kontakt	Bridecontact	Battery contact
3603.034	Batterie-Isolation	Isolateur pile	Battery insulation
3603.039	Deckplatte/ Ste.	Couvre mécan.	Setting lev. cover
3612.114	Modul	Module	Module
3621.033.RK	Spule	Bobine	Coil
3622.032	Stator	Stator	Stator
3715.089.RK	Rotor	Rotor	Rotor
4000.102	Schraube	Vis	Screw
4000.141	Schraube	Vis	Screw
4000.266	Schraube	Vis	Screw
4000.284	Schraube	Vis	Screw
4000.285	Schraube	Vis	Screw

Cal. 502 512	Zifferblattseite / Côté cadran / Dial side		
Cal. 503/503S	513/513S		
Plan No.	Bestandteile	Fournitures	Spare Parts
2130.115	Zeigerwerkplatte	Plaque maintien	Maintening plate
3004.160	Zeigerstellrad	Renvoi minuterie	Setting wheel
3007.050.CO	Wechselrad	Minuterie	Minute wheel
3301.229	Stundenrad	Canon	Hour wheel
3315.001	Spreizfeder	Clinquant	Washer
4000.279	Schraube	Vis	Screw

Abweichungen / Divergences / Deviations

Cal. 502	Werkseite / Côté mouvement / Movement side		
Plan No.	Bestandteile	Fournitures	Spare Parts
2030.012.CO	Zentrumbrücke	Pont centre	Centrebridge
3136.093.CO	Sekundenrad	Rouessecondes	Second-wheel
3305.210.CO	Minutenrohr	Chaussée	Cannon pinion

Cal. 512	Werkseite / Côté mouvement / Movement side		
Plan No.	Bestandteile	Fournitures	Spare Parts
2000.519	Werkplatte	Platine	Main plate
2030.012.CO	Zentrumbrücke	Pont centre	Centrebridge
3136.093.CO	Sekundenrad	Rouessecondes	Second-wheel
3305.210.CO	Minutenrohr	Chaussée	Cannon pinion

Cal. 505/S 507	Werkseite / Côté mouvement / Movement side		
Plan No.	Bestandteile	Fournitures	Spare Parts
3015.060	Kupplungshebel	Bascule	Yoke

Cal. 513/S	Werkseite / Côté mouvement / Movement side		
Plan No.	Bestandteile	Fournitures	Spare Parts
2000.519	Werkplatte	Platine	Main plate

Cal. 515/S 517	Werkseite / Côté mouvement / Movement side		
Plan No.	Bestandteile	Fournitures	Spare Parts
2000.519	Werkplatte	Platine	Main plate
3015.060	Kupplungshebel	Bascule	Yoke

Abweichungen / Divergences / Deviations

Cal. 503S/505S	Werkseite/ Côté mouvement/ Movement side		
Cal. 513S/515S			
Plan No.	Bestandteile	Fournitures	Spare Parts
3612.117	Modul	Module	Module
3621.036.RK	Spule	Bobine	Coil

Batterien / Piles / Batteries

502-509, 503S-505S	Nr. 371	SR 920 SW
512-519, 513S-515S	Dim.Ø x H:	9,50 x 2,06

Werkaufbau

Assemblage

Assembling

10 1/2''' 505/505S
11 1/2''' 515/515S

10 1/2''' 507
11 1/2''' 517

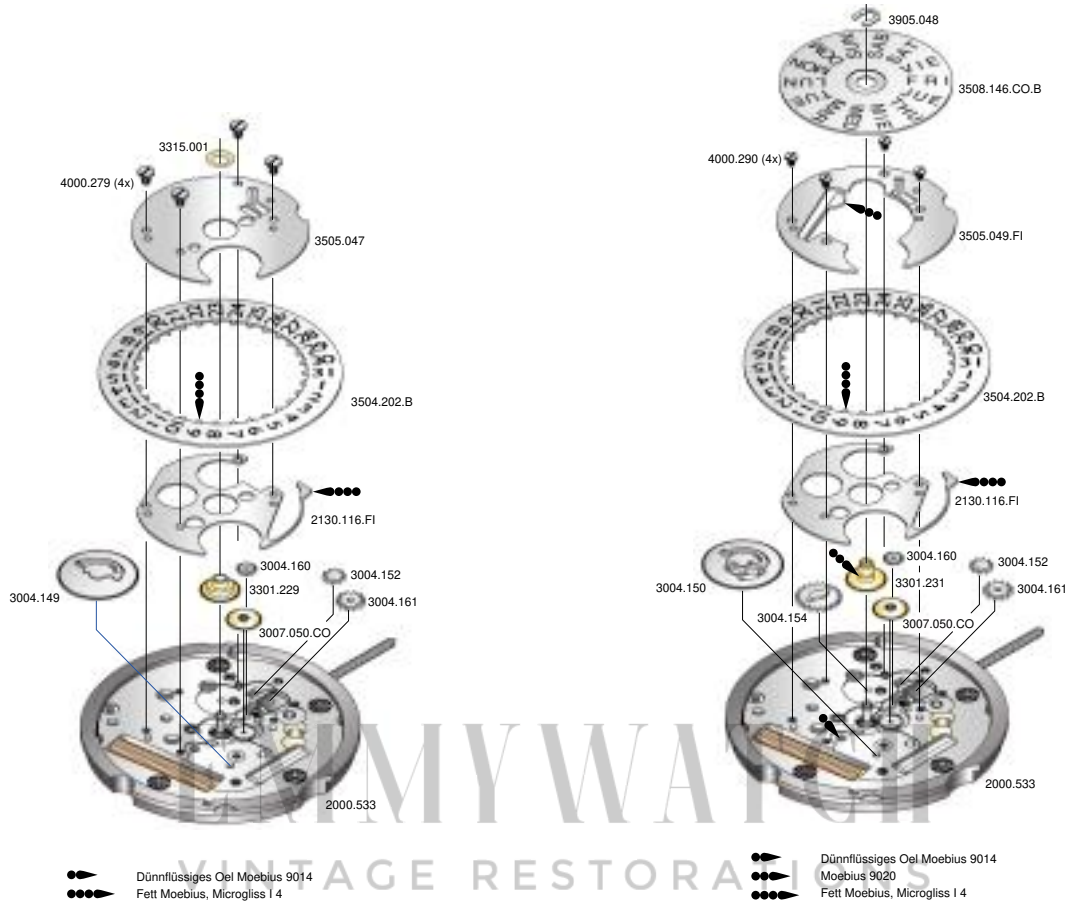

Cal. 505/S	Zifferblattseite / Côté cadran / Dial side		
Plan No.	Bestandteile	Fournitures	Spare Parts
2130.116.FI	Kalenderplatte	Plauecalendrier	Date ind. plate
3004.160	Zeigerstellrad	Renvoi minuterie	Setting wheel
3004.149	Datummitn.-rad	Renvoi entraîn.	Ind. driving wheel
3004.161	Verbindungsrad-Kupplungtrieb	Renvoi pig. coulant	Sliding pinon setting wheel
3004.152	Umkehrad	Baladeur	Sliding gear
3007.050.CO	Wechselrad	Minuterie	Minute wheel
3301.229	Stundenrad	Canon	Hour wheel
3315.001	Spreizfeder	Cinquant	Washer
3504.202.B	Datumanzeiger	Bague	Date indicator
3505.047	Kal.-Abdeckplatte	Couverclecalend.	Date ind. cover
4000.279	Schraube	Vis	Screw

Cal. 507	Zifferblattseite / Côté cadran / Dial side		
Plan No.	Bestandteile	Fournitures	Spare Parts
2130.116.FI	Kalenderplatte	Plauecalendrier	Date ind. plate
3004.160	Zeigerstellrad	Renvoi minuterie	Setting wheel
3004.150	Datummitn.-rad	Renvoi entraîn.	Ind. driving wheel
3004.161	Verbindungsrad-Kupplungtrieb	Renvoi pig. coulant	Sliding pinon setting wheel
3004.152	Umkehrad	Baladeur	Sliding gear
3004.154	Korrekturrad	Roue corr. disque	Correction wheel
3007.050.CO	Wechselrad	Minuterie	Minute wheel
3301.231	Stundenrad	Canon	Hour wheel
3504.202.B	Datumanzeiger	Bague	Date indicator
3505.049.FI	Kal.-Abdeckplatte	Couverclecalend.	Date ind. cover
3508.146.CO.B	Tagesscheibe	Disquejour	Day indicator
3905.048	Klem. f. Dat.sch.	Clavette disque	Date ind. spr. clip
4000.290	Schraube	Vis	Screw

Abweichungen / Divergences / Deviations

Cal. 515/S	Zifferblattseite / Côté cadran / Dial side		
Plan No.	Bestandteile	Fournitures	Spare Parts
3505.203.B	Datumanzeiger	Bague	Date indicator

Abweichungen / Divergences / Deviations

Cal. 517	Zifferblattseite / Côté cadran / Dial side		
Plan No.	Bestandteile	Fournitures	Spare Parts
3504.203.B	Datumanzeiger	Bague	Date indicator
3508.147.CO.B	Tagesscheibe	Disquejour	Day indicator

3. Leistungen

3. Performances

3. Performances

Kaliber Calibre Caliber	Bedingungen Conditions Conditions	Momentaner Gang Marche instantanée Instantaneous rate	Stromaufnahme Consommation courant Power consumption	Drehmoment Couple utile Torque	Gangreserve Autonomie Autonomy
	Einheit / Unité / Unit Typ.Wert / Valeur / value	Mi (s/month)	I (µA)	T (µNm) sec. min.	A (Monat/mois/month)
502-517	1,55 V 23°C	- 10/+ 20	1,29 < 1,70	10,7 509	45
503S-515S	Batt./ Pile 43,0 mAh		2,10 < 2,45	7,8 370	28
Magnetfeldabschirmung / Résist. aux champs magn. / Resist. to magnetic fields			18,8 Oe	1500 A/M	Norm CE
Betriebstemperatur / Température d'opération / Operating temperature			0-50°C		
Schockresistenz / Résistance au choc / Shock resistance			NIHS 91-10		

4. Elektr. Messungen

4. Contrôles électriques

4. Electrical checking

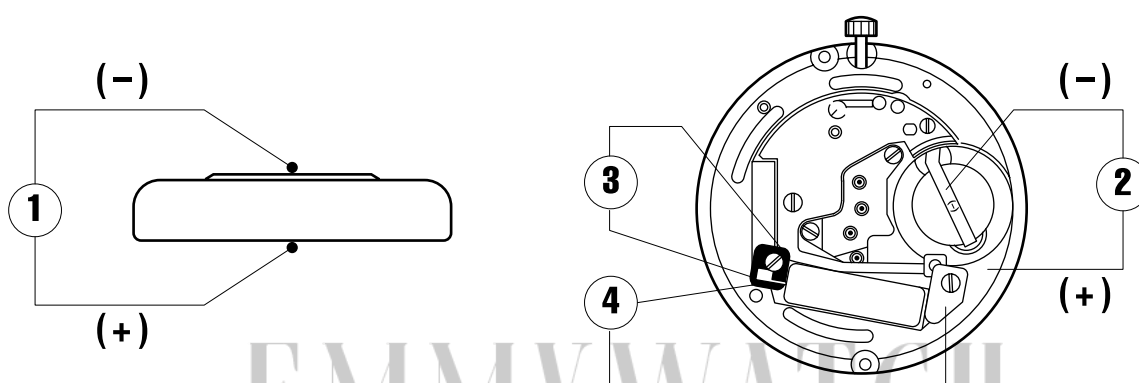

EMMYWATCH
VINTAGE RESTORATIONS

Kaliber Calibre Caliber	Pos. Pos. Pos.	Einheit Unité Unit	Messwerte Valeurs mesurées Measured values	Kontrolle Contrôle Check	Bemerkungen Remarques Remarks
502-517 503S-515S	1	V	1,55	Batterie-Spannung Tension de la pile Battery voltage	Batterie herausnehmen und messen Enlever et mesurer la pile Remove battery for measuring
502-517 503S-515S	2	µA	1,29 < 1,70 (1) = 2,10 < 2,45 (2) = 2,60 < 2,95	Stromaufnahme Consom. de courant Power consumption	Ohne Batterie, mit externer Speisung Sans pile, avec alimentation externe Without battery, with external power supply
502-517 503S-515S	2	V	≤ 1,30	Funktionskontrolle bei Minimalspannung Contrôle de fonctionnement à tension minimale Check with lowest possible voltage	Ohne Batterie, mit externer Speisung Sans pile, avec alimentation externe Without battery, with external power supply
502-517 503S-515S	3	kΩ	1,90-2,10 2,45-2,55	Spulenwiderstand Résistance de la bobine Resistance of the coil	Ohne Batterie Sans pile Without battery
502-517 503S-515S	4	kΩ	∞	Spulenisolation Isolation de la bobine Coil insulation	Ohne Batterie Sans pile Without battery
502-517 503S-515S		Sek./Monat sec./mois sec./month	- 10/+ 20	Induktivsonde 60 Sek. Senseur inductif 60 sec. Inductive sensor 60 sec.	Mit Batterie Avec pile With battery
(1) Mit fixem Motorimpuls & Sekundenzeiger / Avec impulsion moteur fixe & aiguille de secondes / With fix motor puls & second-hand					
(2) Mit fixem Motorimpuls & Sekundenscheibe 85mg / Avec impulsion moteur fixe & disque de secondes 85mg / With fix motor puls & second-disc 85mg					

5. Zeigerwerk

5. Aiguillage

5. Dial-train

Kaliber Calibre Caliber	Zeigerwerk Aiguillage Height of dial train	Einzelteil-Höhe mm				Höhe ab Zifferblattauflage mm			
		Hauteur de la pièce ind. mm				Dépassement platine mm			
		Height of individ. piece mm				Height from base mm			
		No.	A	B	C	D	E	F	G
502, 512		1	2,80	1,75	2,83	1,62	1,13	0,80	–
503-507* 503S-505S		1	2,77	1,75	4,44	2,09	1,10	0,80	1,50
513-517* 513S-515S		2	3,12	2,10	4,79	2,09	1,45	1,15	1,85

* Ausser 24-Stunden-Anzeige mittels Zeiger / Excepté indication 24 heures par aiguille / Except 24-hour indication by hand

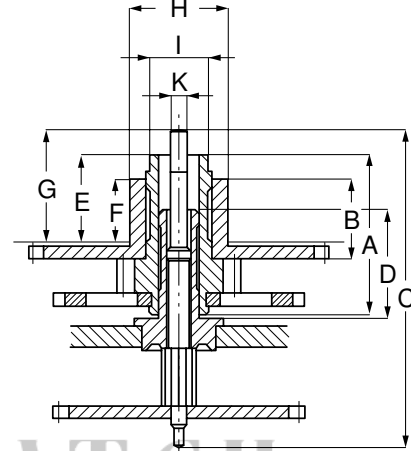
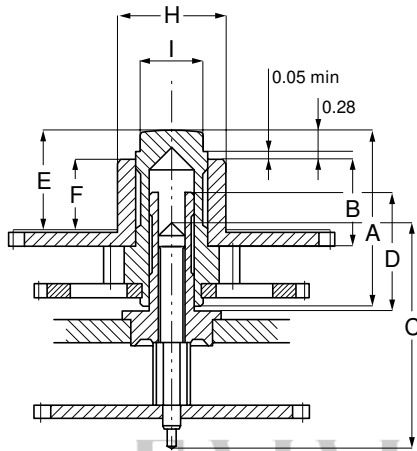

EMMYWATCH
VINTAGE RESTORATIONS

Die Zeiger dürfen nur bei zentral abgestützter Räderwerkbrücke gesetzt werden.
Der Aufpressdruck darf 30 N (3,0 kp) nicht übersteigen.

Lors de la pose des aiguilles, le pont de rouage doit être soutenu.
La force de chassage ne doit pas dépasser 30 N (3,0 kp).

Hands can only be set if train wheel bridge is supported by a movement holder.
Pressure while setting hands must not exceed 30 N (3,0 kp).

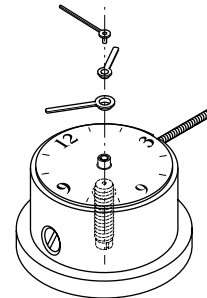

Ø Zeigeranpassung mm		
Ø Ajustement aiguilles mm		
Ø Adjustment of hands mm		
H	I	K
1,20	0,70	0,20

Zifferblattdicke mm		
Epaisseur du cadran mm		
Dial thickness mm		
1 standard	0,40	
2	0,75	

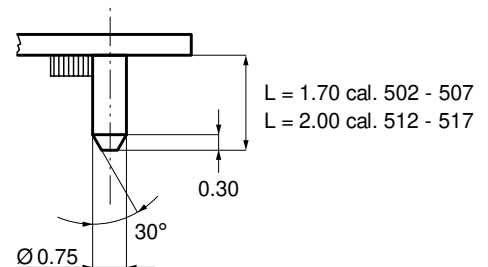

Für Einzelheiten verlangen Sie bitte die entsprechenden Zeigerwerkpläne!
Pour plus de détails demandez nos plans d'aiguillage!
For more detailed information please ask for the corresponding hand drawings!

6. Einschalen

6. Emboîtage

6. Casing

10 1/2''' 502, 503/503S
505/505S, 507

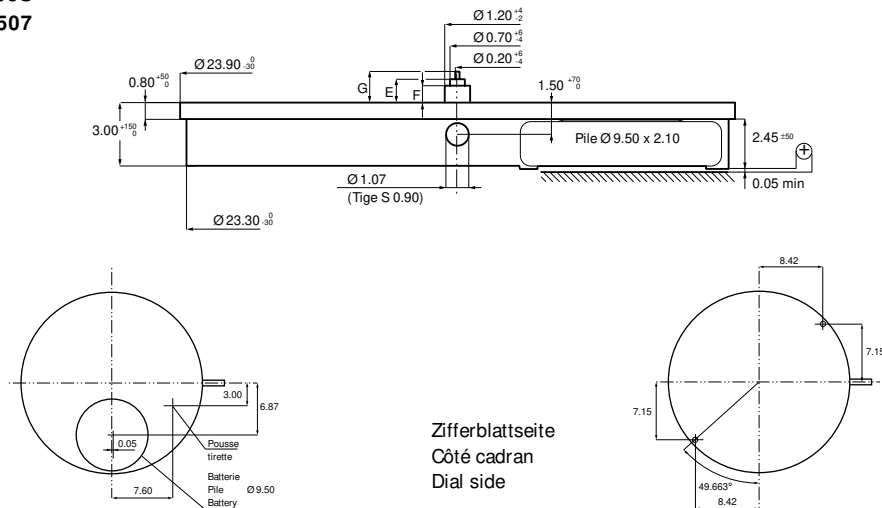

Seite gegen Gehäuseboden
Côté fond de boîte
Case back side

Zifferblattseite
Côté cadran
Dial side

11 1/2''' 512, 513/513S
515/515S, 517

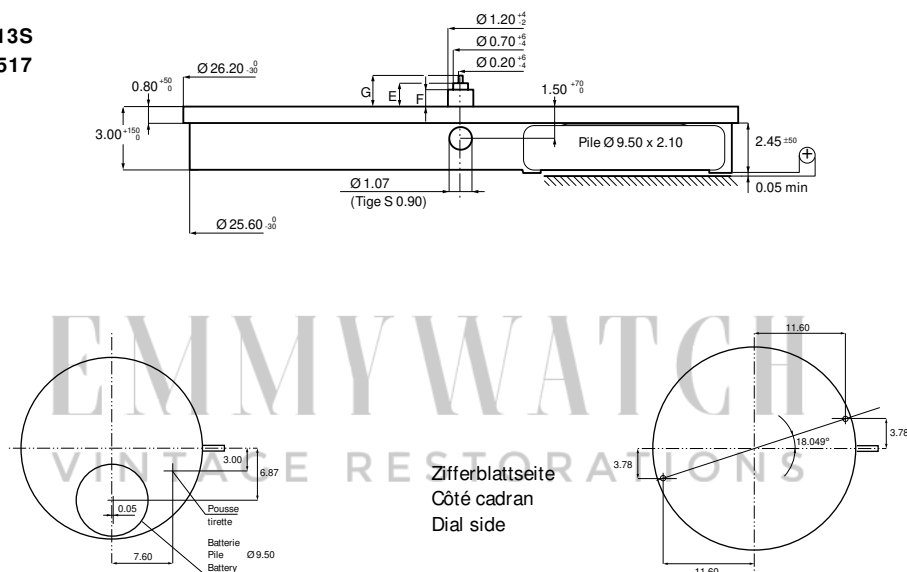

Seite gegen Gehäuseboden
Côté fond de boîte
Case back side

Zifferblattseite
Côté cadran
Dial side

505-517

Kalender-Schnellkorrektur Correction rapide du calendrier Quick change date function

Hinweis: In der Kalenderschaltphase von 22.30 - 24.00 Uhr kann das Datum korrigiert werden, wobei das Datum des folgenden Tages eingestellt werden muss, da in diesem Fall um Mitternacht keine automatische Schaltung erfolgt.

Attention: Le réglage de la date peut être effectué pendant la phase de saut entre 22.30 et 24.00 heures. Dans ce cas, il faut adapter la date du jour suivant car il n'y a pas de saut à minuit.

Indication: During the calendar jump phase between 10.30pm and 00.00am the date can be changed. In this case the date of the following day needs to be set as there will be no jump at midnight.

507-517

Wochentag-Schnellkorrektur Correction rapide du jour Quick change weekday function

Hinweis: Ausserhalb der Kalenderschaltphase kann der Wochentag, bzw. die Sprache uneingeschränkt gewechselt werden. Jeweils um 24.00 Uhr erscheint zuerst für ca. 2 Stunden die zweite Sprache bis die Anzeige auf die effektiv eingestellte Sprache wechselt.

Attention: A l'exception de la phase de saut, le jour ou la langue peut être changée sans restriction. Chaque fois à minuit la deuxième langue apparaît pour environ 2 heures. La langue effective est seulement indiquée après le deuxième saut.

Indication: Beyond the calendar jump phase the weekday or language can be changed without restrictions. Regularly around midnight the second language appears at first for approximately 2 hours before the original set language appears in a second weekday jump.

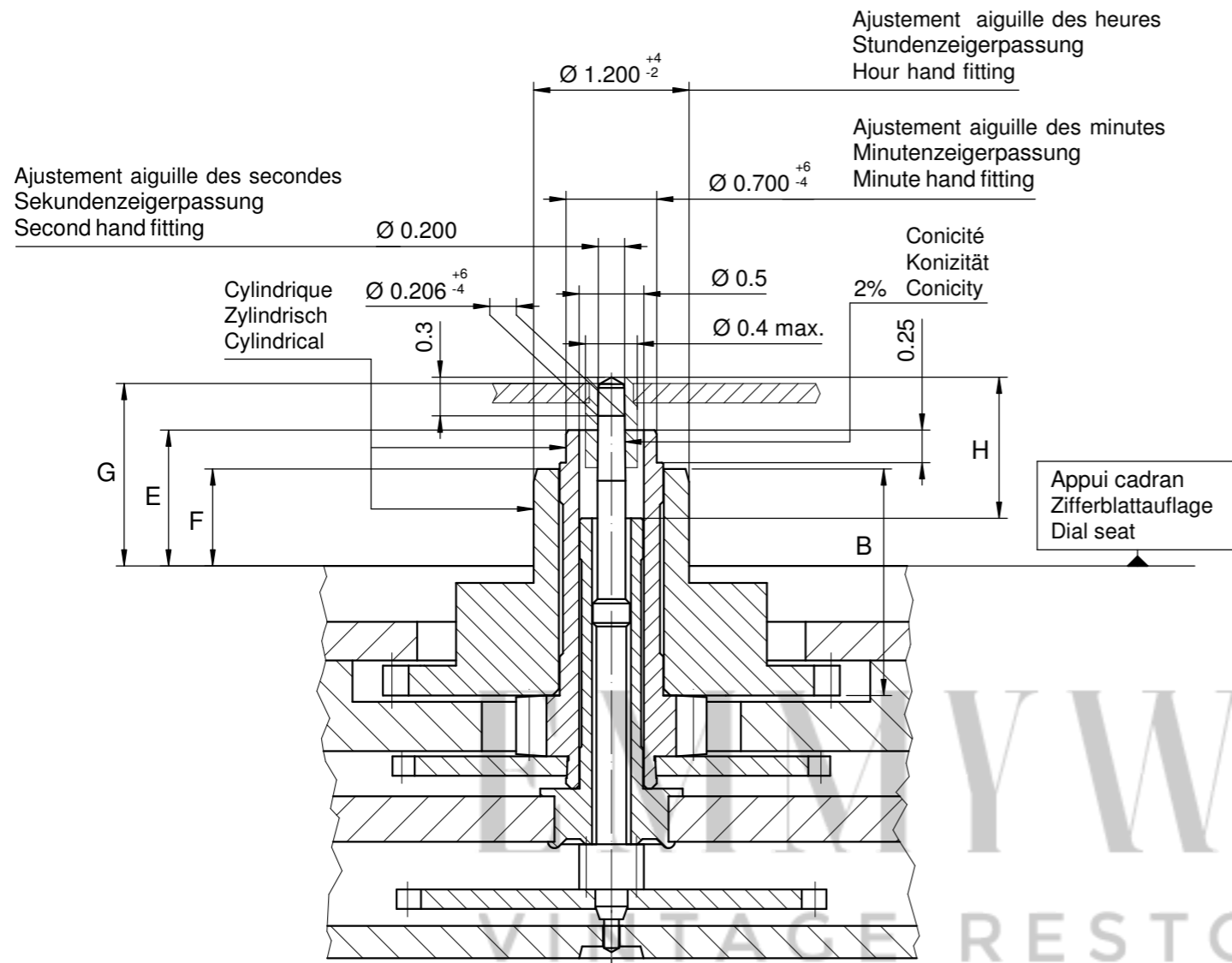

Heures / minutes / secondes
 Stunden / Minuten / Sekunden
 Hours / minutes / seconds

Aiguillage no Zeigerwerkhöhe Nr. Hand fitting height No	Dépassement Höhe über Zifferblattauflage Height over dial seat			Longueur Länge Length		Epaisseur max. (peinture comprise) Max. Dicke (inkl. Farbe) Max. thickness (paint included)			
	Pignon des secondes Sekundentrieb Second pinion	Chaussée Minutenrohr Cannon-pinion	Roue des heures Stundenrad Hour wheel	H	B	Cadran Zifferblatt Dial			Aiguilles Zeiger Hands
						Sous l'aiguille des secondes Unter Sekundenzeiger Under second hand	Sous l'aiguille des minutes Unter Minutenzeiger Under minute hand	Sous l'aiguille des heures Unter Stundenzeiger Under hour hand	
1	G	E	F	1.09	1.75	0.95	0.65	0.40	0.15
2	1.46	1.05	0.75	1.44	2.10	1.30	1.00	0.75	0.15

YWATCH
 VINTAGE RESTORATIONS

	Aig. des secondes Sekundenzeiger Second hand	Aig. des minutes Minutenzeiger Minute hand	Aig. des heures Stundenzeiger Hour hand	Lors de la pose d'aiguilles, le mouvement doit être soutenu. Beim Zeigersetzen muss das Werk abgestützt werden. The movement needs to be supported for hand setting.
mg max.	10	30	30	Masse / Masse / Weight *
µNm max.	0.08	0.70	0.70	Balourd / Unwucht / Unbalance *
gmm ² max.	0.4	-	-	Inertie / Massenträgheit / Inertia *
N max.	30	40	40	Force de chassage / Aufpresskraft / Force

Sous réserve de toutes modifications

Aenderungen vorbehalten

All modifications reserved

Aiguillages Zeigerwerkhöhen Hand fitting heights	Issued	10 Mär 1999	gd
	Modified	20 Apr 2011 ÄA 10340	ps
	Released	Yes	
	Tolerance	µm	
	Scale	20 : 1 (A3H)	
RONDA	503, 503S, 505, 505S, 513, 513S, 515, 515S		Sous réserve de modifications Aenderungen vorbehalten Modifications reserved
	No.	3316.059	07

* En cas de données différentes, veuillez contacter le service après-vente

* Bei abweichenden Werten, bitte technischen Kundendienst anfragen

* In case of different values, please contact the customer service

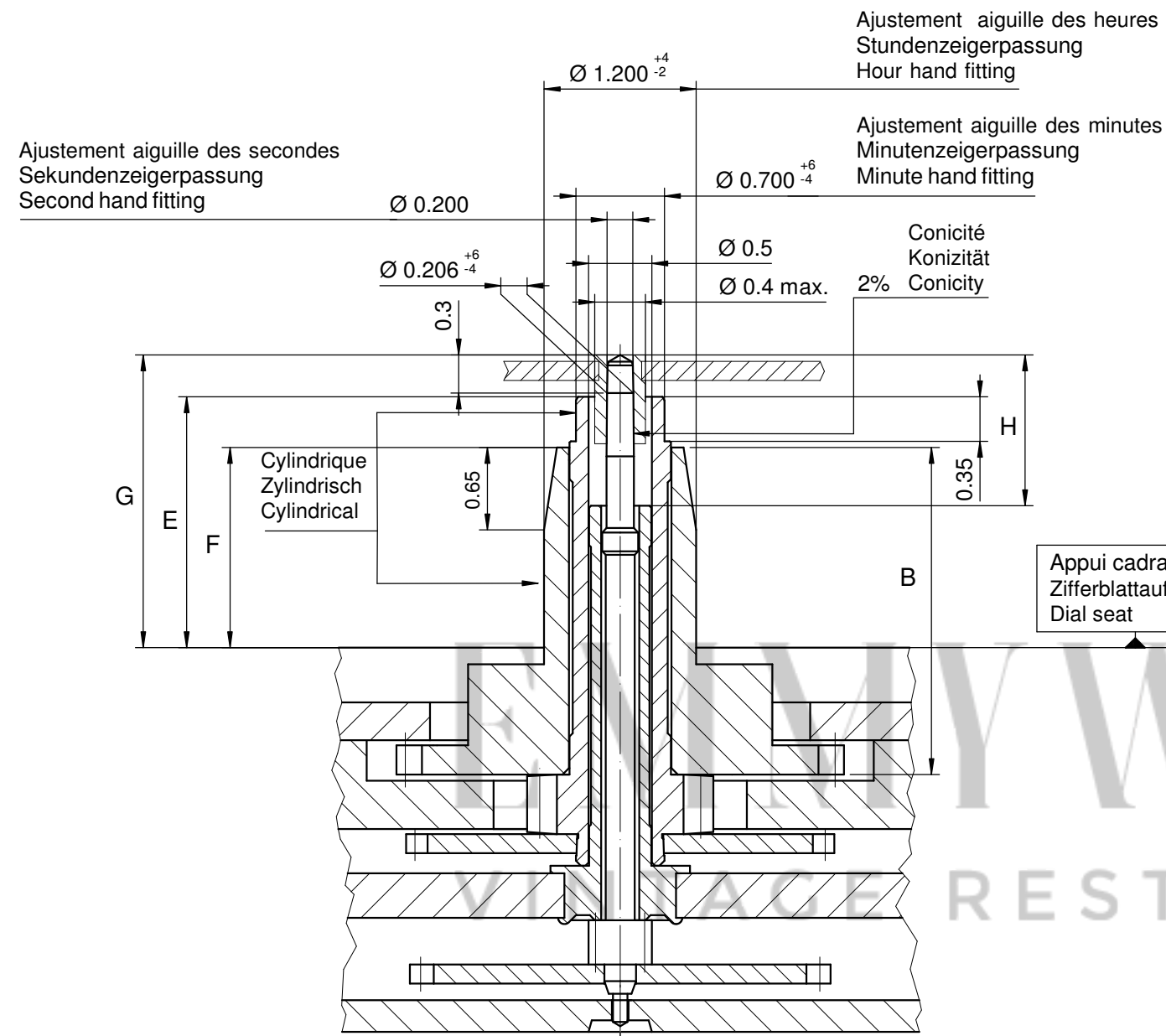

Heures / minutes / secondes
 Stunden / Minuten / Sekunden
 Hours / minutes / seconds

Aiguillage no. Zeigerwerkhöhe Nr. Hand fitting height No	Dépassement Höhe über Zifferblattauflage Height over dial seat			Longueur Länge Length		Epaisseur max. (peinture comprise) Max. Dicke (inkl. Farbe) Max. thickness (paint included)			
	Pignon des secondes Sekundentrieb Second pinion	Chaussée Minutenrohr Cannon-pinion	Roue des heures Stundenrad Hour wheel	H	B	Cadran Zifferblatt Dial			Aiguilles Zeiger Hands
						Sous l'aiguille des secondes Unter Sekundenzeiger Under second hand	Sous l'aiguille des minutes Unter Minutenzeiger Under minute hand	Sous l'aiguille des heures Unter Stundenzeiger Under hour hand	
6	G	E	F	H	B	1.80	1.55	0.40	0.15

	Aig. des secondes Sekundenzeiger Second hand	Aig. des minutes Minutenzeiger Minute hand	Aig. des heures Stundenzeiger Hour hand	Lors de la pose d'aiguilles, le mouvement doit être soutenu. Beim Zeigersetzen muss das Werk abgestützt werden. The movement needs to be supported for hand setting.
mg max.	10	30	30	Masse / Masse / Weight *
µNm max.	0.08	0.70	0.70	Balourd / Unwucht / Unbalance *
gmm ² max.	0.4	-	-	Inertie / Massenträgheit / Inertia *
N max.	30	40	40	Force de chassage / Aufpresskraft / Force

Sous réserve de toutes modifications

Aenderungen vorbehalten

All modifications reserved

Aiguillages
Zeigerwerkhöhen
Hand fitting heights

10 1/2", 11 1/2"

RONDA

**503, 503S, 505, 505S,
 513, 513S, 515, 515S**

Issued	10 Mär 1999	gd
Modified	24 Mai 2011 ÄÄ 11034	dh
Released	Yes	
Tolerance	µm	
Scale	20 : 1 (A3H)	
Sous réserve de modifications Aenderungen vorbehalten Modifications reserved		
No.	3316.067	03

* En cas de données différentes, veuillez contacter le service après-vente

* Bei abweichenden Werten, bitte technischen Kundendienst anfragen

* In case of different values, please contact the customer service