

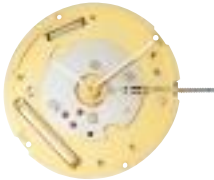

Ronda 1004 Movement Parts (1)

Compiled by EmmyWatch - <https://www.emmywatch.com>

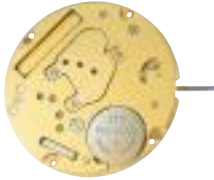

10 1/2'''

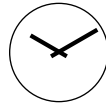

1002

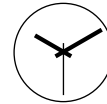

1003

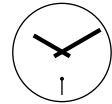

1004

EMMYWATCH

1. Werkdimensionen

1. Dimensions

des mouvements

1. Movement

dimensions

Kaliber	Ø Total	Ø Werksitz	Werkhöhe	Höhe Batterie	Höhe Stellwelle	Höhe Werkauflage
Calibre	Ø Total	Ø Encageage	Hauteur mouvement	Hauteur pile	Hauteur tige	Hauteur filet
Caliber	Ø Total	Ø Case fitting	Movement height	Height of battery	Height of stem	Movement rest
Einh./ Unité/ Unit	mm	mm	mm	mm	mm	mm
1002-1004	23,90	23,30	1,90	1,90	0,75	0,35
Stellwellengewinde/ Filetage de la tige/ Stem thread: Ø 0,90 mm				Weg/ Chemin/ Length of travel: 1,00 mm		

2. Funktionen

2. Fonctions

2. Functions

Kaliber	Stellwellenpos.	Funktionen
Calibre	Pos. de tige	Fonctions
Caliber	Stem position	Functions
1002	1	Normale Position / Position normale / Running position Zeiger stellen, mit Unterbruch der Motorimpulse
	2	Mise à l'heure, avec interruption des impulsions moteur Hand setting, with interruption of the motor pulses
1003-1004	1	Normale Position / Position normale / Running position Zeiger stellen, Sekunden-Stopp mit Unterbruch der Motorimpulse
	2	Mise à l'heure, stop-seconde avec interruption des impulsions moteur Hand setting, stop-second with interruption of the motor pulses

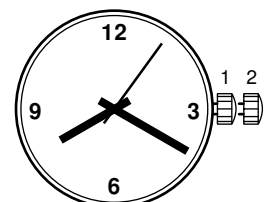

10 1/2''' 1002, 1003

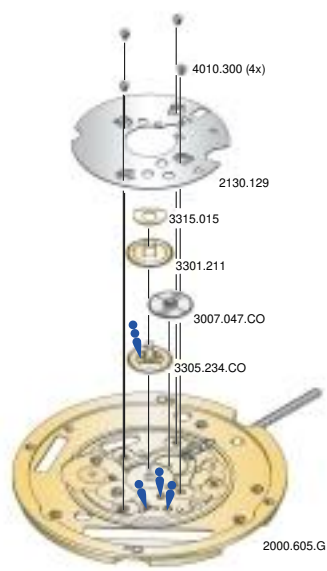
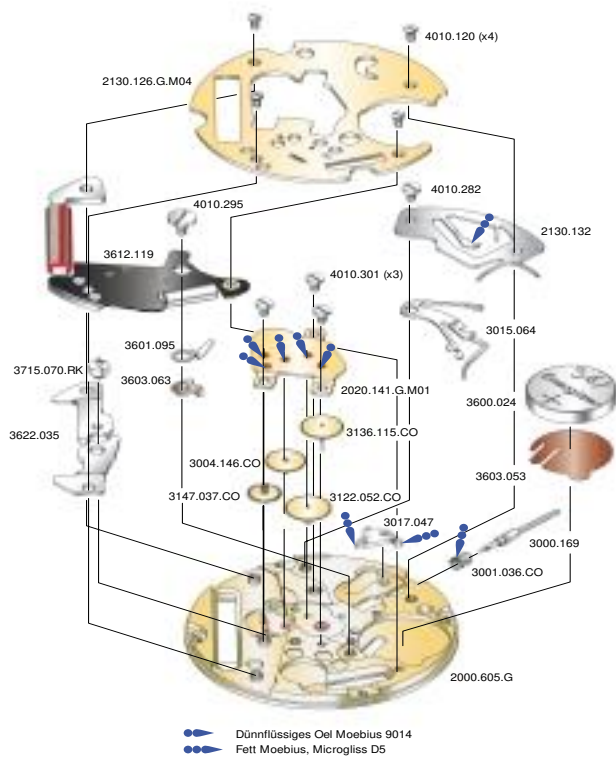

••••• Dünnflüssiges Oel Moebius 9014
 ••••• Fett Moebius, Microgliss D5

••••• Dünnflüssiges Oel Moebius 9014
 ••••• Fett Moebius, Microgliss D5, Jisma 124

EMMYWATCH
 RESTORATIONS

Cal. 1003	Werkseite / Côté mouvement / Movement side		
Plan no.	Bestandteile	Fournitures	Spare Parts
2000.605.G	Werkplatte	Platine	Main plate
2020.141.G.MO1	Räderwerkbrücke	Pont rouge	Train w. bridge
2130.126.G.MO4	Modul-Abdeckp.	Couvre module	Module cover pl.
2130.132	Deckplatte	Couvre mec.	Setting lever cov.
3000.169	Stellwelle	Tige	Stem
3001.036.CO	Kupplungstrieb	Pignon coulant	Sliding pinion
3004.146.CO	Sekundenzw.rad	Renvoi seconde	Second driv. wh.
3015.064	Wippe	Bascule	Yoke
3017.047	Winkelhebel	Tirette	Setting lever
3122.052.CO	Kleinbodenrad	Rouemoyenne	Third wheel
3136.115.CO	Sekundenrad	Rouesecondes	Second-wheel
3147.037.CO	Zwischenrad	Roue interméd.	Intermed. wheel
3600.024	Batterie	Pile	Battery
3601.095	Batterie-Kontakt	Bridecontact	Battery contact
3603.053	Batterie-Isolation	Isolateur pile	Battery insulation
3603.063	Kontakt Isolation	Isolateur bride	Batt. contact ins.
3612.119	Modul m. Spule	Module av. bobine	Module w. coil
3622.035	Stator	Stator	Stator
3715.070.RK	Rotor	Rotor	Rotor
4010.120	Schraube	Vis	Screw
4010.282	Schraube	Vis	Screw
4010.295	Schraube	Vis	Screw
4010.301	Schraube	Vis	Screw

Abweichungen / Divergences / Deviations

Cal. 1002	Werkseite / Côté mouvement / Movement side		
Plan No.	Bestandteile	Fournitures	Spare Parts
2000.602.G	Werkplatte	Platine	Main plate
2020.140.G.MO1	Räderwerkbrücke	Pont rouge	Train w. bridge
2130.126.G.MO1	Modul-Abdeckp.	Couvre module	Module cover pl.
3147.036.CO	Zwischenrad	Roue interméd.	Intermed. wheel
3612.121	Modul m. Spule	Module av. bobine	Module w. coil
3715.071.RK	Rotor	Rotor	Rotor

Cal. 1003	Zifferblattseite / Côté cadran / Dial side		
Plan no.	Bestandteile	Fournitures	Spare Parts
2000.605.G	Werkplatte	Platine	Main plate
2130.129	Zeigerw.haltepl.	Plaque maintien	Maintaining plate
3007.047.CO	Wechselrad	Minuterie	Minute wheel
3301.211	Stundenrad	Canon	Hour wheel
3305.234.CO	Minutenrohr	Chaussée	Cannon pinion
3315.015	Spreizfeder	Clinquant	Washer
4010.300	Schraube	Vis	Screw

Abweichungen / Divergences / Deviations

Cal. 1002	Zifferblattseite / Côté cadran / Dial side		
Plan No.	Bestandteile	Fournitures	Spare Parts
2000.602.G	Werkplatte	Platine	Main plate
3305.257.CO	Minutenrohr	Chaussée	Cannon pinion

Batterien / Piles / Batteries

1002-1004	Nr. 341 Dim.Ø x H:	SR 920 SW 7.90 x 1,45
-----------	-----------------------	--------------------------

10 1/2''' 1004

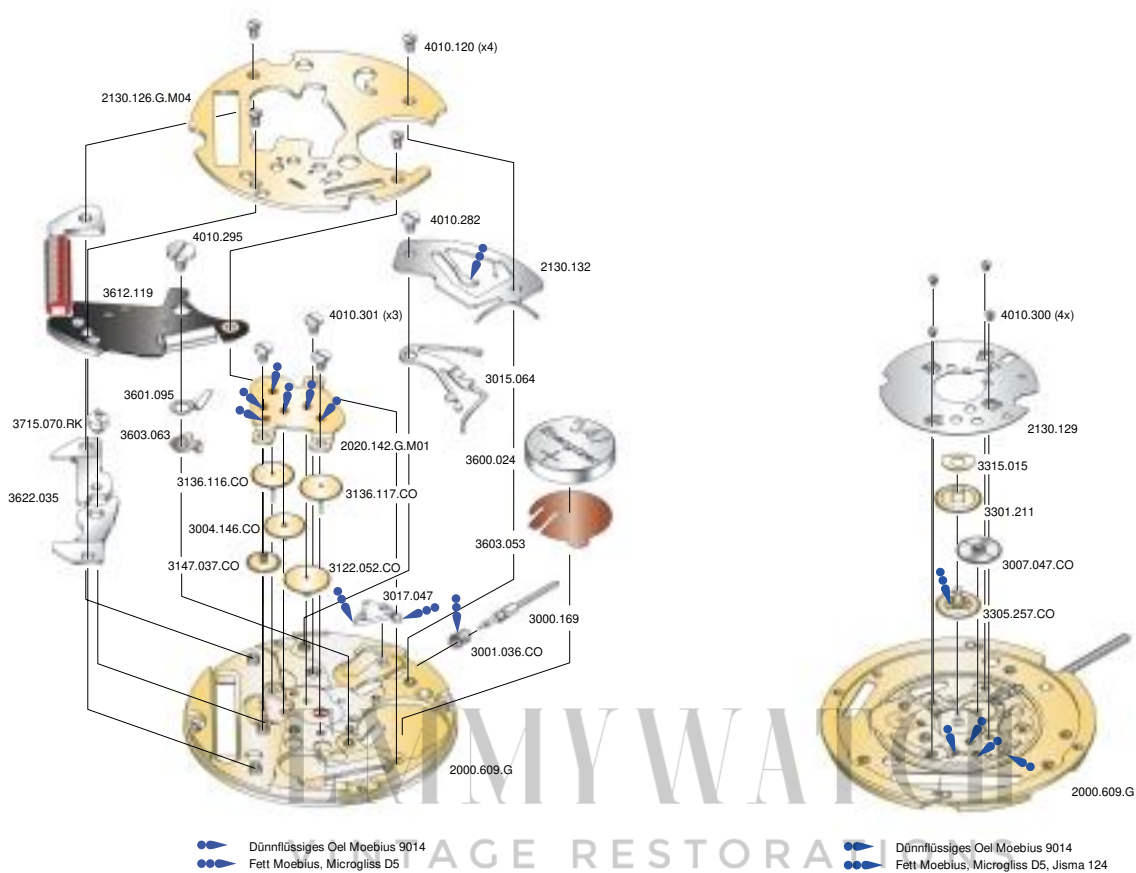

••••• Dünnflüssiges Öl Moebius 9014
 ••••• Fett Moebius, Microgliss D5

••••• Dünnflüssiges Öl Moebius 9014
 ••••• Fett Moebius, Microgliss D5, Jisma 124

Cal. 1004	Werkseite / Côté mouvement / Movement side		
Plan no.	Bestandteile	Fournitures	Spare Parts
2000.609.G	Werkplatte	Platine	Main plate
2020.142.G.MO1	Räderwerkbrücke	Pont rouge	Train w. bridge
2130.126.G.MO4	Modul-Abdeckp.	Couvre module	Module cover pl.
2130.132	Deckplatte	Couvre mec.	Setting lever cov.
3000.169	Stellwelle	Tige	Stem
3001.036.CO	Kupplungstrieb	Pignon coulant	Sliding pinion
3004.146.CO	Sekundenzw.rad	Renvoi seconde	Second driv. wh.
3015.064	Wippe	Bascule	Yoke
3017.047	Winkelhebel	Tirette	Setting lever
3122.052.CO	Kleinbodenrad	Rouey moyenne	Third wheel
3136.116.CO	Kl. Sek. Radwelle pivot	Roue axe pet. sec.	Sm. sec. w.
3136.117.CO	Sek.-rad kurz	Roue sec. courte	Sec. wheel short
3147.037.CO	Zwischenrad	Roue interméd.	Intermed. wheel
3600.024	Batterie	Pile	Battery
3601.095	Batterie-Kontakt	Bride contact	Battery contact
3603.053	Batterie-Isolation	Isolateur pile	Battery insulation
3603.063	Kontakt Isolation	Isolateur bride	Batt. contact ins.
3612.119	Modul m. Spule	Module av. bobine	Module w. coil
3622.035	Stator	Stator	Stator
3715.070.RK	Rotor	Rotor	Rotor
4010.120	Schraube	Vis	Screw
4010.282	Schraube	Vis	Screw
4010.295	Schraube	Vis	Screw
4010.301	Schraube	Vis	Screw

Cal. 1004	Zifferblattseite / Côté cadran / Dial side		
Plan no.	Bestandteile	Fournitures	Spare Parts
2000.609.G	Werkplatte	Platine	Main plate
2130.129	Zeigerw.haltepl.	Plaque maintien	Maintaining plate
3007.047.CO	Wechselrad	Minuterie	Minute wheel
3301.211	Stundenrad	Canon	Hour wheel
3305.257.CO	Minutenrohr	Chaussée	Cannon pinion
3315.015	Spreifeder	Clinquant	Washer
4010.300	Schraube	Vis	Screw

3. Leistungen

3. Performances

3. Performances

Kaliber Calibre Caliber	Bedingungen Conditions Conditions	Momentaner Gang Marche instantanée Instantaneous rate	Stromaufnahme Consommation courant Power consumption	Drehmoment Couple utile Torque	Gangreserve Autonomie Autonomy
	Einheit / Unité / Unit Typ.Wert / Valeur / value	Mi (s/month)	I (µA)	T (µNm) sec. min.	A (Monat/mois/month)
1002	1,55 V 23°C	- 10/+ 20	0,50 < 0,65	46	37
1003-1004	1,55 V 23°C Batt./ Pile 13,5 mAh	- 10/+ 20	0,65 < 0,95	3,9 195	28
Magnetfeldabschirmung / Résist. aux champs magn. / Resist. to magnetic fields			18,8 Oe	1500 A/M	Norm 
Betriebstemperatur / Température d'opération / Operating temperature			0-50°C		
Schockresistenz / Résistance au choc / Shock resistance			NIHS 91-10		

Anzeige Ende der Batterielaufzeit EOL

Der Sekundenzeiger hält während 4 Sekunden an und holt dann die 4 Sprünge kurzfristig nach.

Indication de fin de vie de pile

L'aiguille de seconde s'arrête durant 4 secondes puis fait rapidement 4 pas.

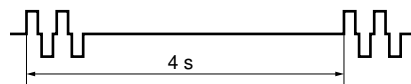

Battery end-of-life indication EOL

The second hand stops for 4 seconds before executing rapidly the 4 steps.

Folgende Kaliber sind mit dem EOL-System ausgerüstet:

Les calibres suivants sont munis du système EOL:

The following calibers are equipped with EOL:

Swiss Made 10 1/2''' – 1003, 1004

4. Elektr. Messungen

4. Contrôles électriques

4. Electrical checking

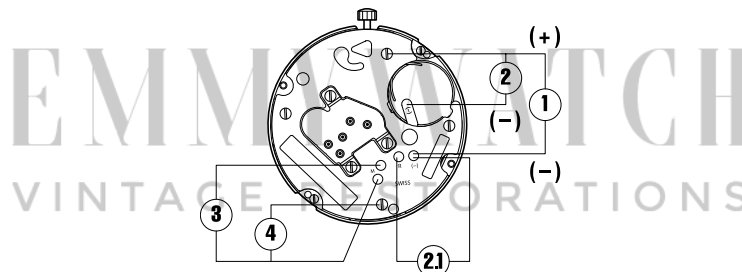

Kaliber Calibre Caliber	Pos. Pos. Pos.	Einheit Unité Unit	Messwerte Valeurs mesurées Measured values	Kontrolle Contrôle Check	Bemerkungen Remarques Remarks
1002-1004	1	V	1,55	Batterie- Spannung Tension de la pile Battery voltage	Mit Batterie Avec pile With battery
1002	2	µA	0,55 < 0,70 ~ 2,35 *	Stromaufnahme (* bei Puls, Periode = 5 Sek.) Consommation de courant (* pend. impuls., p. = 5 sec.)	Ohne Batterie, mit externer Speisung Sans pile, avec alimentation externe
1003-1004	2	µA	0,65 < 0,95	Power consumption (* by pulse, period = 5 sec.)	Without battery, with external supply
1002-1004	2	V	< 1,30	Funktionskontrolle bei Minimalspannung Contrôle de fonctionnement à tension minimale Check with lowest possible voltage	Ohne Batterie, mit externer Speisung Sans pile, avec alimentation externe Without battery, with external power supply
1002-1004	2.1	V		Motorimpuls 8x beschleunigt Impulsions de moteur 8x accélérées Motor pulses 8x accelerated	Mit Batterie od. externer Speisung 1.55V Avec pile ou alimentation externe de 1.55V With battery or external power supply 1.55V
1002 1003-1004	3	KΩ	2,10-2,30 2,50-2,70	Spulenwiderstand Résistance de la bobine Resistance of the coil	Ohne Batterie Sans pile Without battery
1002-1004	4	KΩ	∞	Spulenisolation Isolation de la bobine Coil insulation	Ohne Batterie Sans pile Without battery
1002-1004		Sek./Monat sec./mois sec./month	- 10/+ 20	Induktivsonde 60 Sek. Senseur inductif 60 sec. Inductive sensor 60 sec.	Mit Batterie Avec pile With battery

5. Zeigerwerk

5. Aiguillage

5. Dial-train

Kaliber	Zeigerwerk	Einzelteil-Höhe			mm				Höhe ab Zifferblattauflage	mm
Calibre	Aiguillage	Hauteur de la pièce ind.			mm				Dépassement platine	mm
Caliber	Height of dial train	Height of individ. piece			mm				Height from base	mm
	No.	A	B	C	D	E	F	G		
1002	0	1,65	0,80	—	1,15	0,90	0,60	—		
	1	1,85	1,00	—	1,25	1,10	0,80	—		
1003	0	1,62	0,80	3,12	1,14	0,90	0,60	1,20		
	1	1,82	1,00	3,42	1,42	1,10	0,80	1,50		
1004	1	1,85	1,00	2,37	1,14	1,10	0,80	0,45		

10 1/2''' 1002

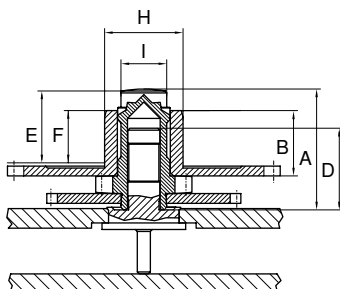

1003

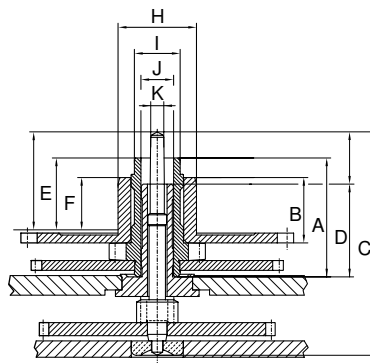

1004

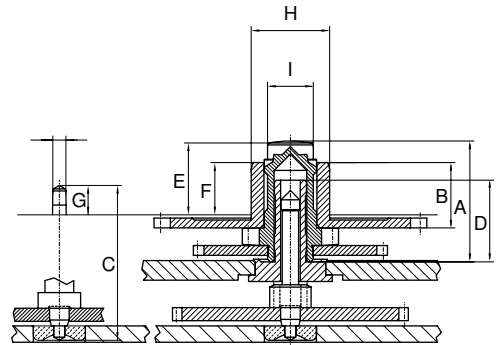

Die Zeiger dürfen nur bei zentral abgestützter Räderwerkbrücke gesetzt werden.
Der Aufpressdruck darf 25 N (2,5 kp) nicht übersteigen.

Lors de la pose des aiguilles, le pont de rouage doit être soutenu.
La force de chassage ne doit pas dépasser 25 N (2,5 kp).

Hands can only be set if train wheel bridge is supported by a movement holder.
Pressure while setting hands must not exceed 25 N (2,5 kp).

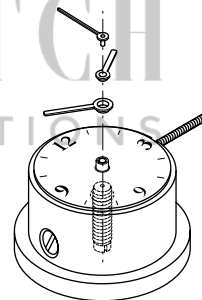

6. Einschalen

6. Emboîtage

6. Casing

Ø Zeigeranpassung	mm	
Ø Ajustement des aiguilles	mm	
Ø Adjustment of hands	mm	
H	I	K
1,20	0,70	0,20

Zifferblattdicke	mm
Epaisseur du cadran	mm
Dial thickness	mm
0	0,30
1 standard	0,40

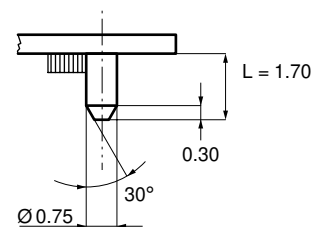

Für Einzelheiten verlangen Sie bitte die entsprechenden Zeigerwerkpläne!
Pour plus de détails demandez nos plans d'aiguillage!
For more detailed information please ask for the corresponding hand drawings!

Schraube Nr. :
Vis No. : 4000.236
Screw No. :

Schraube Nr. :
Vis No. : 4000.237
Screw No. :

Werkbefestigungsschrauben
Vis d'emboîtage
Disc screws for casing

10 1/2''' 1002, 1003, 1004

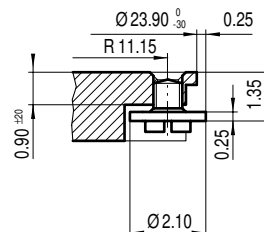
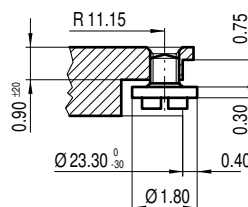

Gehäuseplan
Plan de cage
Case drawing

10 1/2''' 1002

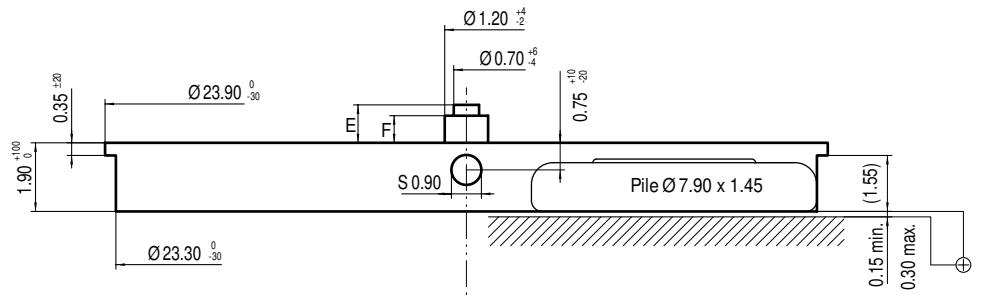

10 1/2''' 1003

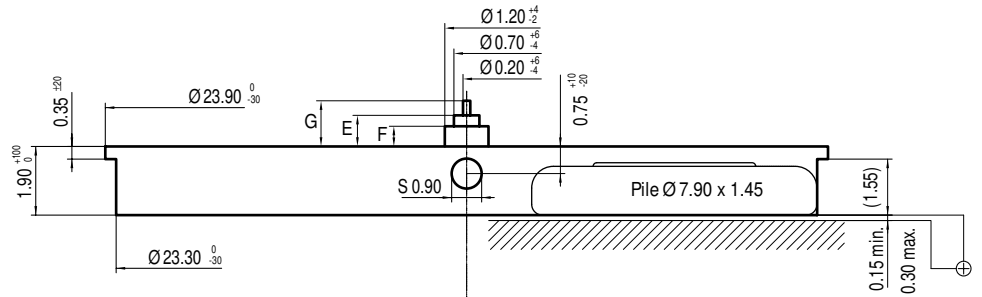

10 1/2''' 1004

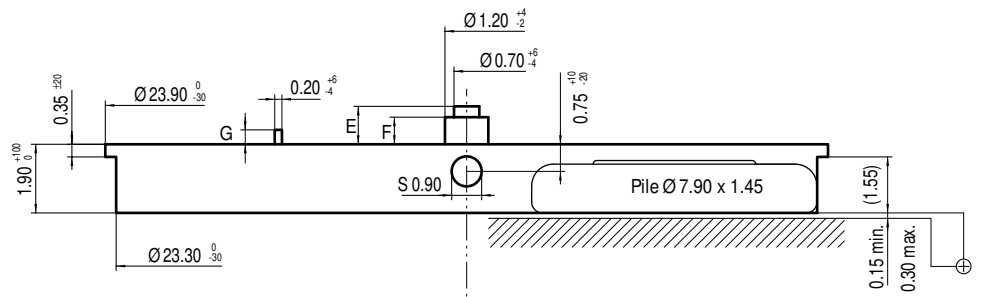

10 1/2''' 1002, 1003

EMMYWATCH
VINTAGE RESTORATIONS

Seite gegen Gehäuseboden
Côté fond de boîte
Case back side

Zifferblattseite
Côté cadran
Dial side

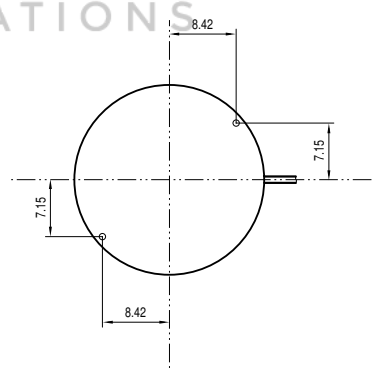
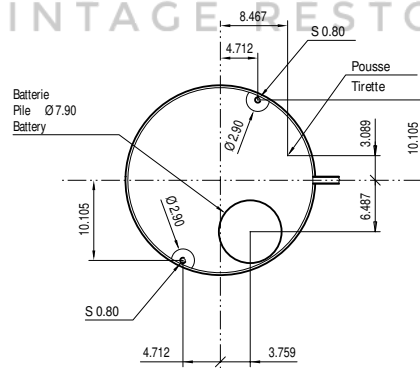

10 1/2''' 1004

Seite gegen Gehäuseboden
Côté fond de boîte
Case back side

Zifferblattseite
Côté cadran
Dial side

