



EMMYWATCH
VINTAGE RESTORATIONS

Omega 651 Movement Parts (1)

Compiled by EmmyWatch - <https://www.emmywatch.com>

CALIBRE-KALIBER-CALIBRE

651

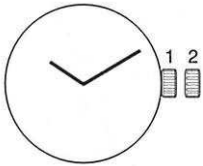
<p>10 1/2" ø 23.30 mm</p>	
<p>Hauteur mouvement Werkhöhe Movement height</p>	<p>2.50 mm</p>
<p>Réserve de marche / Gangreserve / Power reserve Nombre de rubis / Rubine Zahl / Jewel number Fréquence / Frequenz / Frequency Angle de levée / Hebungswinkel der Unruh / Angle of lift</p>	<p>44 h 17 21'600 A/h 52°</p>



Français
Deutsch
English

Assemblage du mécanisme de mise à l'heure
(Liste des fournitures par ordre d'assemblage)

Zusammenstellen des Zeigermechanismus
(Bestanteilliste in Montager Reihenfolge)





Assembling of hand-setting mechanism

(Parts listed in order of assembly)

100		440
401		450
410		260
407		445
443		5445 (2x)
5443	(1x)	240
435		250

EMMYWATCH
VINTAGE RESTORATIONS

Lubrification - Schmierung - Lubrication

	Huile fine Dünnflüssiges Öl Fine oil	Moebius 9010
	Huile épaisse à viscosité élevée ou graisse Dickflüssiges druckfestes Öl oder Fett Thick, pressure-resistant oil or grease	Moebius D 5
	Graisse / Fett / Grease	Jismaa 124
	Huile spéciale pour levées Spezial Öl für Hebungen Special oil for pallet stones	Moebius 941/9415

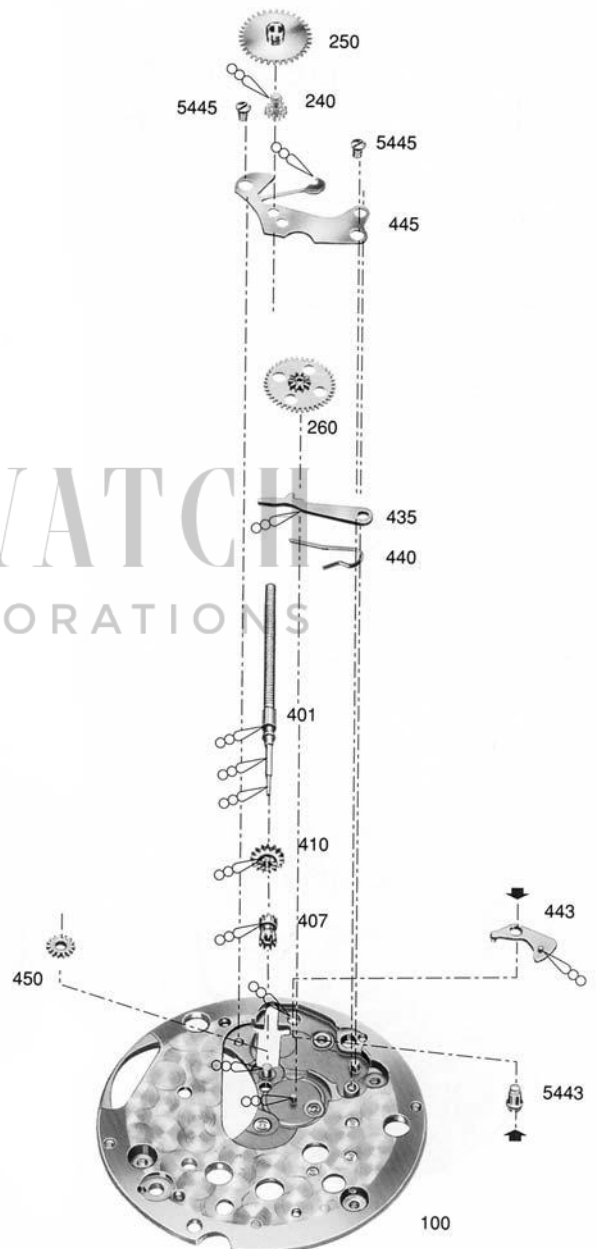

Assemblage du mouvement de base
(Liste des fournitures par ordre d'assemblage)

Zusammenstellen des Basiswerkes
(Bestanteileliste in Montager Reihenfolge)

Assembling of the basis movement
(Parts listed in order of assembly)

100	5125	(1x)
705	721	
220		(375
210	121/3	(303/2
201		(3024
110	5121	(1x)
5110	420	
	182	423
180/1	5423	(2x)
	425	
105	5425	(1x)
5105	430	(3x)
710	415	(1x)
125	5415	(1x)

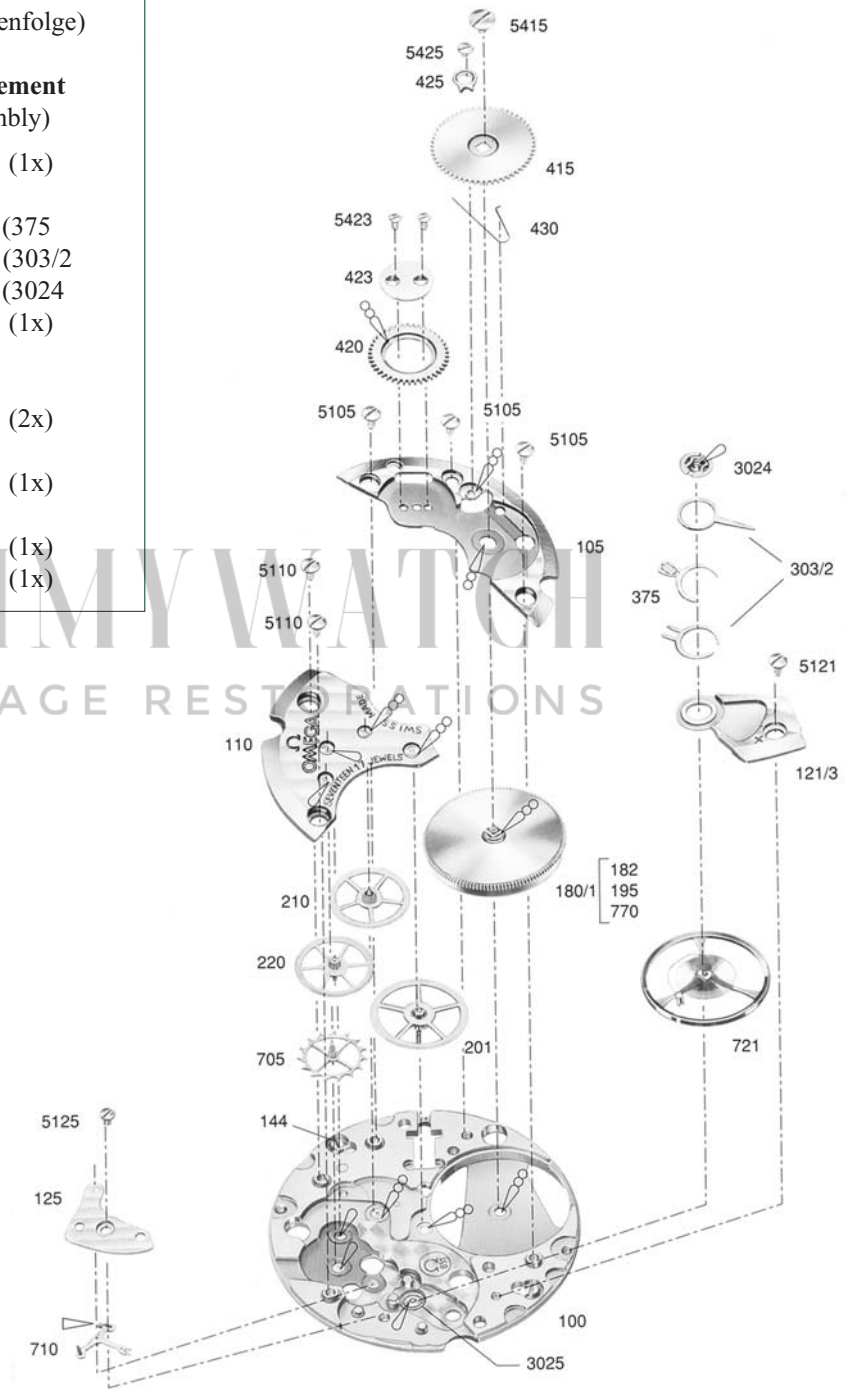

Liste des fournitures-Ersatzteilleiste-Spare parts list

No	No. ISO	Désignation	Bezeichnung	Designation
100	10.020.07	Platine, empierrée	Werkplatte, mit Steinen	Main plate, jewelled
105	10.041.07	Pont de barillet, empierré	Federhausbrücke, mit Steinen	Barrel bridge, jewelled
110	10.048.07	Pont de rouage, empierré	Räderwerkbrücke, mit Steinen	Train wheel bridge, jewelled
121/3	10.058.61	Pont de balancier, pour amortisseur et porte-piton, pour raquette avec flèche	Unruhbrücke für Stossicherung und Spiralklötzchenträger, für Rücker mit Stiel	Balance bridge, for shock-absorber and stud support, for regulator with pointer
125	10.057.07	Pont d'ancre, empierré	Ankerbrücke, mit Stein	Pallet bridge, jewelled
144	10.300	Fixateur de cadran	Zifferblatthalter	Dial fastener
182	20.030	Barillet (tambour et couvercle)	Federhaus (Trommel und Deckel)	Barrel (drum and cover)
195	20.060	Arbre de barillet	Federwelle	Barrel arbor
201	30.015	Roue de centre	Minutenrad	Centre wheel
210	30.025	Roue moyenne	Kleinbodenrad	Third wheel
220	30.027	Roue de seconde	Sekundenrad	Second wheel
224	30.027.13	Roue de seconde, long pivot dessous	Sekundenrad, mit langern Zapfen unten	Second wheel, with long lower pivot
240	31.080	Chaussée entraîneuse	Mitnehmer-Minutenrohr	Driver cannon pinion
250	31.046	Roue des heures	Stundenrad	Hour wheel
260	31.041	Roue de minuterie	Wechselrad	Minute wheel
303/2	40.302.61	Raquette en 2 pièces, à flèche, pour porte-piton Etachron	Rücker, zweiteilig, mit Stiel, für Spi ralklötzchenträger Etachron	Two-piece regulator, with pointer, for stud support Etachron
375	40.200	Porte-piton	Spiralklötzchenträger	Stud support
401	51.010.21	Tige de remontoir, diamètre de filetage 0,90 mm	Aufzugwelle, Gewindedurchmesser 0,90 mm	Winding stem, thread diameter 0,90 mm
407	31.121	Pignon coulant	Kupplungstrieb	Sliding pinion
410	31.120	Pignon de remontoir	Aufzugtrieb	Winding pinion
415	31.020	Rochet	Sperrrad	Ratchet wheel
420	31.023	Roue de couronne	Kronrad	Crown wheel
423	81.136	Noyau de roue de couronne	Kronradkern	Crown wheel core
425	51.120	Cliquet	Klinke	Click
430	61.080	Ressort de cliquet	Klinkenfeder	Click spring
435	51.050	Bascule de pignon coulant	Kupplungtriebhebel	Yoke
440	61.100	Ressort de bascule	Kupplungshebelfeder	Yoke spring
443	51.080	Tirette	Winkelhebel	Setting lever
445	51.090	Sautoir de tirette	Winkelhebelraste	Setting lever jumper
450	31.100	Renvoi	Zeigerstellrad	Setting wheel
705	30.040	Roue d'échappement	Hemmungsrad	Escape wheel
710	40.010	Ancre	Anker	Pallet fork
714	40.020	Tige d'ancre	Ankerwelle	Pallet staff
721	40.050.21	Balancier annulaire, réglé (pour amortisseur et porte-piton)	Unruh mit glattem Reif, reguliert (für Stossicherung und Spiralklötzchenträger)	Timed annular balance (for shock-absorber and stud support)
728	40.100.21	Axe de balancier (pour amortisseur et balancier annulaire)	Unruhwelle (für Stossicherung und Unruh mit glattem Reif)	Balance staff (for shockabsorber and annular balance)
730	40.120	Plateau double	Doppelscheibe	Double roller
770	20.100	Ressort-moteur	Triebfeder	Main spring
3024	70.500	Amortisseur empierré de balancier, à chasser, à portée, dessus	Stossicherung mit Stein, zum Einpressen, für Unruh, mit Auflage, oben	Jewelled shock-absorber, to press in, for balance, shouldered, for top
3025	70.531	Amortisseur empierré de balancier, à chasser, cylindrique, dessous	Stossicherung mit Stein, zum Einpressen, für Unruh, zylindrisch, unten	Jewelled shock-absorber, to press in, for balance, cylindrical, for bottom

Liste des vis - Schraubenliste - Screws list

No Ω	No. ISO	Vis pour	Schraube für	Screw for
5101	10.020.01	2x Fixage	Werkbefestigung	Case
5102	10.020.02	2x Fixage, spéciale	Werkbefestigung, Spezialausführung	Case, special
5105 1)	10.041.01	3x Pont de barillet	Federhausbrücke	Barrel bridge
5110 1)	10.048.01	2x Pont de rouage	Räderwerkbrücke	Train wheel bridge
5121 1)	10.058.01	1x Pont de balancier	Unruhbrücke	Balance bridge
5125	10.057.01	1x Pont d'ancre	Ankerbrücke	Pallet bridge
5415	31.020.01	1x Rochet	Sperrrad	Ratchet wheel
5423	81.136.01	2x Noyau de roue de couronne	Kronradkern	Crown wheel core
5425	51.120.01	1x Cliquet	Klinke	Click
5443	51.080.01	1x Tirette	Winkelhebel	Setting lever
5445	51.090.01	2x Sautoir de tirette	Winkelhebelraste	Setting lever jumper

1) Vis identiques, identische Schrauben, identical screws 5105, 5110, 5121

EMMYWATCH
VINTAGE RESTORATIONS

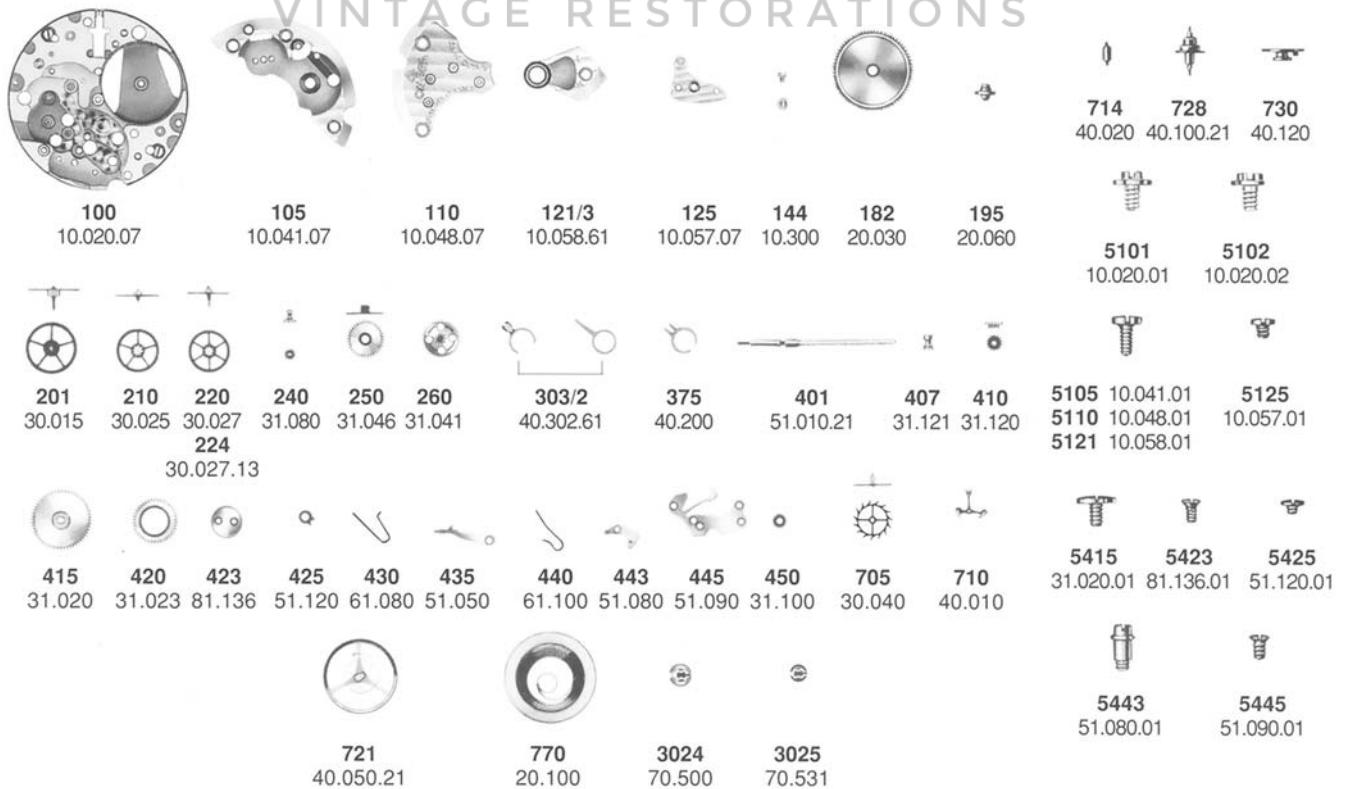

Aiguillage - Zeigerwerk - Hand fitting

Aiguillage	Longueur Länge Length				Dépassement Höhe über Zifferblattauflage Height over dial seat		
	A	B	C	D	E	F	G
Zeigerwerk- höhe Hand fitting height	Chaussée Minuten- rohr Cannon- pinion	Roue des heures Stunden- rad Hour wheel	Pignon des secondes Sekunden- trieb Second wheel pinion	Pignon des secondes Sekunden- trieb Second wheel pinion	Chaussée Minuten- rohr Cannon pinion	Roue des heures Stunden- rad Hour wheel	Pignon des secondes Sekunden- trieb Second wheel pinion
1	1,65	0,95	2,77	sans sec. ohne Sek. without sec. 2,27	1,04	0,74	0,40
2 normal	1,80	1,10	2,77		1,19	0,89	0,40
3	1,95	1,25	2,77		1,34	1,04	0,40
4	2,20	1,50	2,77		1,59	1,29	0,40

EMMYWATCH

VINTAGE RESTORATIONS

