



EMMYWATCH
VINTAGE RESTORATIONS

Frederic Piguet 820 Movement Parts (1)

Compiled by EmmyWatch - <https://www.emmywatch.com>

CARACTERISTIQUES TECHNIQUES

CALIBRE 820

MOUVEMENT 8 ¼’’
CALIBRE QUARTZ

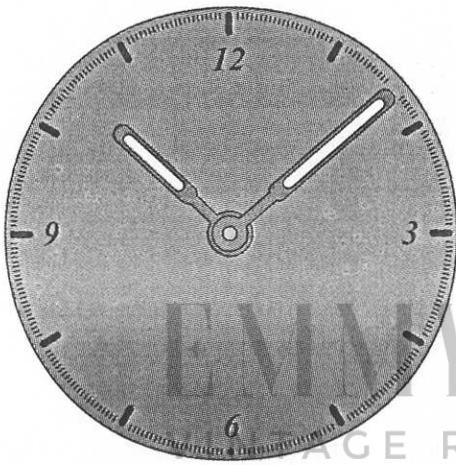

Vue cadran
Calibre 820

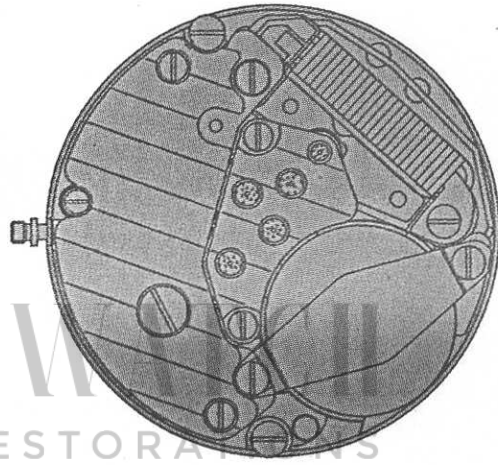





Vue côté mouvement
Calibre 820

DIMENSIONS	820
Ø encageage	18.40 mm
Ø total	18.80 mm
Hauteur de tige	0.90 mm
Hauteur totale	1.95 mm
Réglage	Trimmer
Nombre de rubis	9

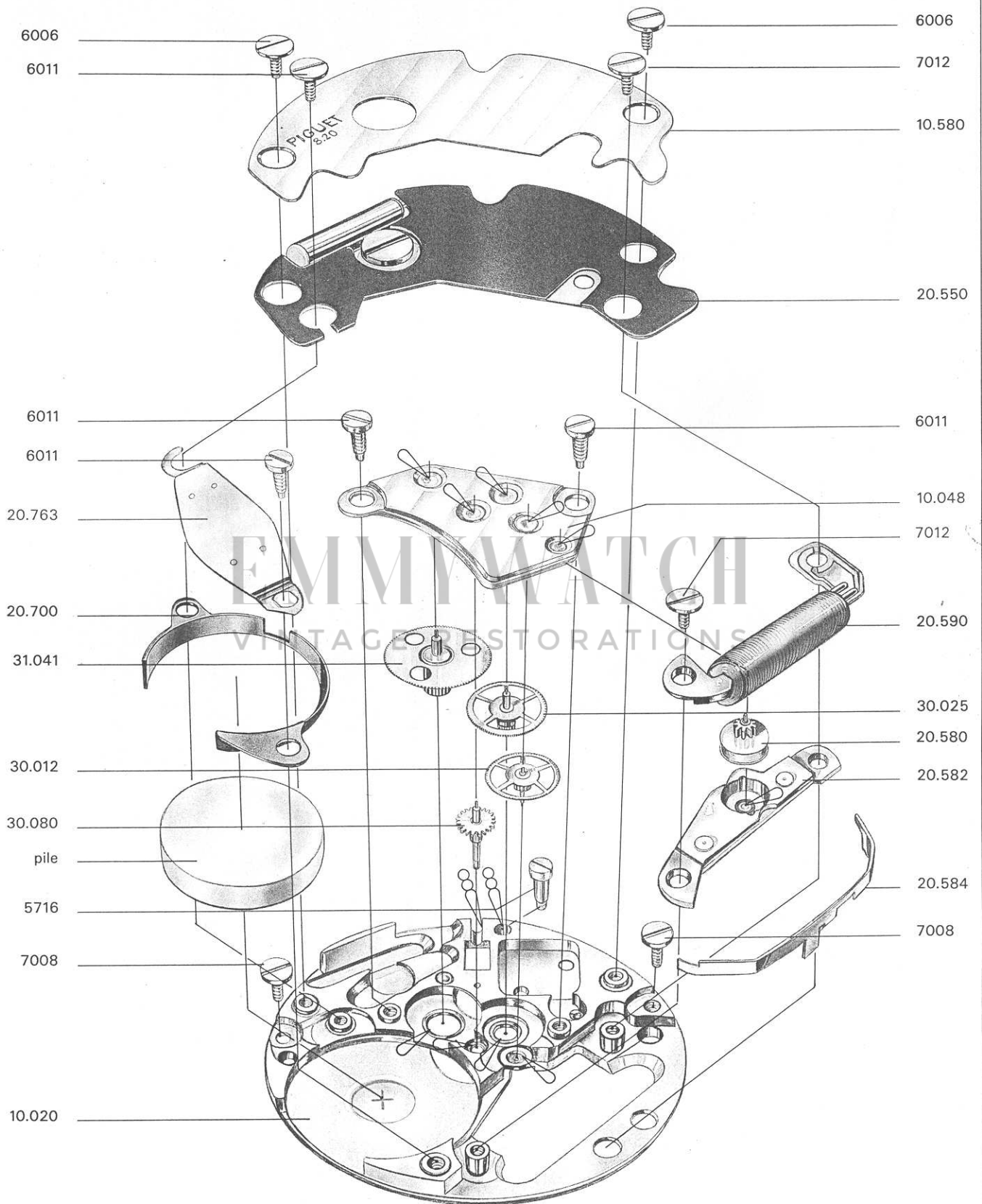
VUE ÉCLATÉE - CÔTÉ SUS
 PLAN DE HUILAGE

CALIBRE 8.20



-  Moebius 9010 - Quartz oil
-  Moebius 8141
-  Moebius Microgliss D 5



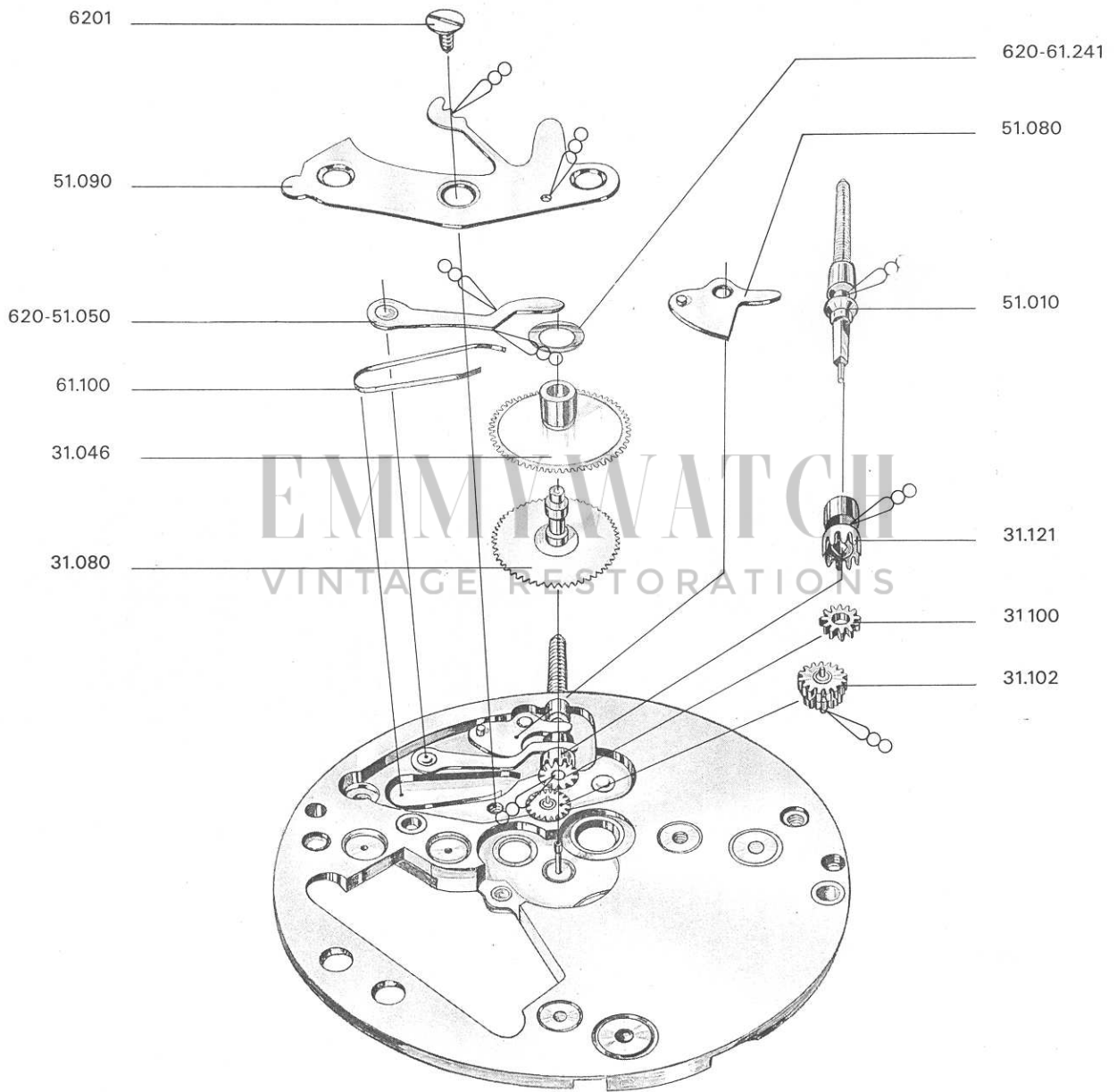

Moebius 8141

Moebius Microgliss D 5





820
10-10.020



10-10.048



10-10.580



10-20.550



10-20.580.1



10-20.582.1



5716



6011



10-20.584



10-20.590.1



10-20.700



10-20.763



10-30.012



10-30.025



6201



7008
7012



10-30.080



10-31.041



10-31.046



10-31.080



10-31.100



10-31.102



6006



7013



10-31.121



10-51.010



6.20-51.050



10-51.080



10-51.090



10-61.100

Pièces agrandies 3 x

EMMY WATCH

VINTAGE RESTORATIONS

LISTE DE FOURNITURES

LIST OF MATERIALS

BESTANTEILE

LISTA DELLE FORNITURE

820	LISTE DE FOURNITURES	LIST OF MATERIALS	BESTANTEILE	LISTA DELLE FORNITURE
10-10.020	Platine	Mainplate	Werkplatte	Piastra
10-10.048	Pont de rouage	Trainwheel bridge	Räderwerkbrücke	Ponte del ruotismo
10-10.580	Support circuit	Electronic unit support	Träger für Elektro-Bauteil	Supporto del circuito
10-20.550	Circuit	Circuit	Schaltung	Circuito
10-20.580.1	Rotor	Rotor	Rotor	Rotore
10-20.582.1	Stator	Stator	Stator	Statore
10-20.584	Ecran magnétique	Magnetic screen	Magnetschirm	Magnetico schermo
10-20.590.1	Bobine	Coil	Spule	Bobina
10-20.700	Enceinte de pile	Battery enclosure	Batterie-Schutzhülle	Recinto per la pila
10-20.763	Bride de pile	Bridle	Bügel	Brida
10-30.012	Mobile intermédiaire	Intermediate reduction	Zwischenrad	Ruota intermedia
10-30.025	Mobile de moyenne	Third wheel	Kleinbodenrad	Ruota mediana
10-30.080	Pignon minutes	Minute pinion	Minutentrieb	Pignone dei minuti
10-31.041	Mobile de minuterie	Minute wheel	Wechselrad	Ruota della minuteria
10-31.046	Roue des heures	Hour wheel	Studenrad	Ruota delle ore
10-31.080	Chaussée entraîneuse	Free cannon pinion	Freies Minutenrohr	Pignone calzante libero
10-31.100	Petit renvoi	Setting wheel	Zeigerstellrad	Rinvio
10-31.102	Renvoi intermédiaire	Motion work setting wheel	Wippenzeigerstellrad	Rinvio della ruota di minuteria
10-31.121	Pignon coulant	Sliding pinion	Kupplungstrieb	Pignone scorrevole
10-51.010	Tige de remontoir	Winding stem	Aufzugwelle	Albero di carica
6.20-51.050	Bascule	Yoke	Kupplungstriebhebel	Bascula del pignone scorrevole
10-51.080	Tirette	Setting lever	Winkelhebel	Tiretto
10-51.090	Sautoir de tirette	Setting lever jumper	Winkelhebelraste	Scatto del tiretto
10-61.100	Ressort de bascule	Yoke spring	Kupplunghebelfeder	Molla della bascula
5716	Vis de tirette	Setting lever screw	Winkelhebelraste Schraube	Vite del tiretto
6006	Vis de support circuit	Electronic unit support screw	Schraube für Träger	Vite del supporto del circuito
6011	Vis de bride de pile	Bridle screw	Bügel Schraube	Vite della brida
6011	Vis de pont de rouage	Trainwheel bridge screw	Räderwerkbrücke Schraube	Vite del ponte del ruotismo
6201	Vis de sautoir de tirette	Setting lever jumper screw	Winkelhebelraste Schraube	Vite del scatto del tiretto
7012	Vis de stator	Stator screw	Stator Schraube	Vite del statore
7008	Vis d'emboîtage	Dog screw	Wekbefestigungs Schraube	Vite di fissaggio
7013	Vis d'emboîtage spéciale	Special dog screw	Spezielle Werkbefestigungs Schraube	Vite di fissaggio speciale



DESCRIPTIF

Affichage

Heures et minutes

Moteur

Type lavet

Résistance magnétique >18,8 Oe Norme CTM

Module

Basse consommation

Fréquence ajustée par Trimmer

Consommation – autonomie

Consommation totale du mouvement ~ 0,6 μ A

Autonomie avec pile 7,90 x 1,40 (14mA/h) ~ 30 mois

7,90 x 1,60 (17mA/h) ~ 35 mois

EMMYWATCH
VINTAGE RESTORATIONS