



France Ebauches 5120 Movement Parts (1)

*Compiled by EmmyWatch - <https://www.emmywatch.com>*



# FRANCE ÉBAUCHES

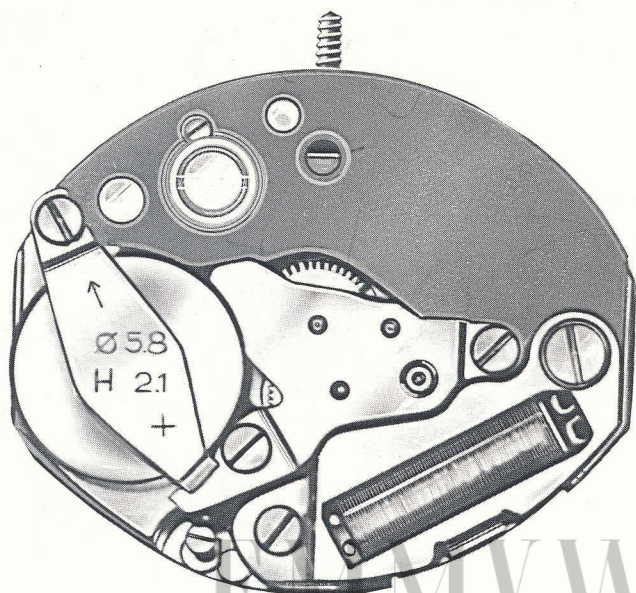

5 1/2 x 6 3/4'''

13,00 x 15,15 mm

**5120**  
**5130 B**

H = 2,60 mm

EMMYWATCH  
VINTAGE RESTORATIONS

## CARACTERISTIQUES TECHNIQUES

### Cage

Dimensions totales  
Dimensions encageage  
Hauteur sur filet  
Hauteur sur tige  
Hauteur maximum

### Tige de mise à l'heure

Diamètre du filetage

### Résonateur

Fréquence

### Moteur

Nombre d'impulsions  
par minute

Exécution : 3-5 rubis

## TECHNICAL DATA

### Frame

Overall dimensions  
Casing dimensions  
Height at bead  
Height at stem  
Maximum height

### Hand-setting stem

Threading diameter

### Resonator

Frequency

### Motor

Number of impulses p/minute

Version : 3-5 jewels

## TECHNISCHE DATEN

### Gestell

Gesamte-Abmessungen  
Gehäuse-Passung  
Höhe am Wulst  
Höhe an der Welle  
Maximale Höhe

### Stellwelle

Gewindedurchmesser

### Resonator

Frequenz

### Motor

Impulszahl p/Minute

Ausführung : 3-5 Steine

## 技术资料

### 外架 (框架)

全部大细  
壳大细  
车轮边缘高度  
弦杆高度  
最高度

### 机芯止动杆 线条直径

### 谐振器 振荡

### 电动机 每分钟/冲量

型式: 3-5 钻 (宝石)

mm  
毫米

13,000 x 15,550  
13,000 x 15,150  
0,400  
1,000  
2,600

0,900

32 768 Hz

<b>5120</b>	<b>5130 B</b>
3	60



5120

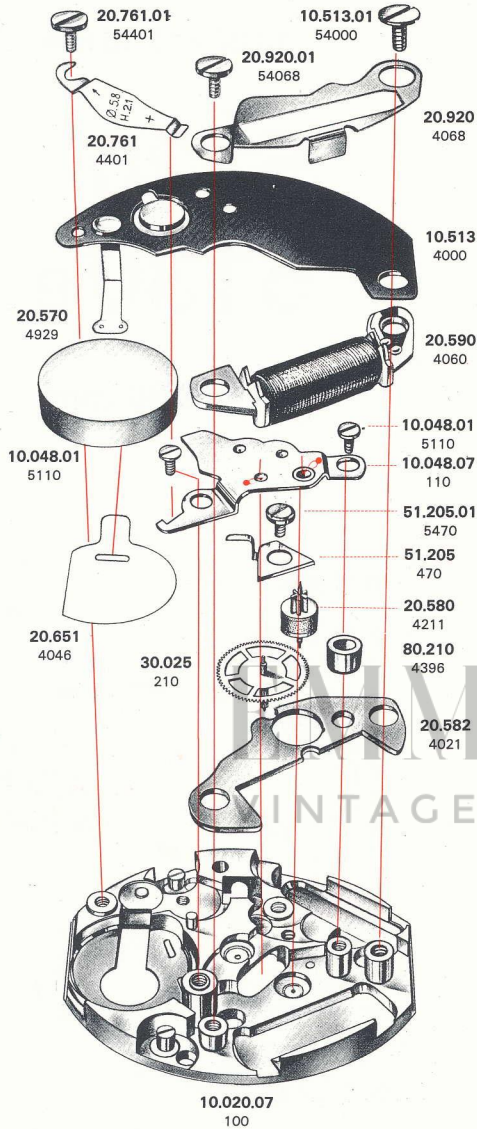
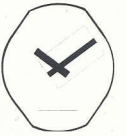

10.020.07  
100

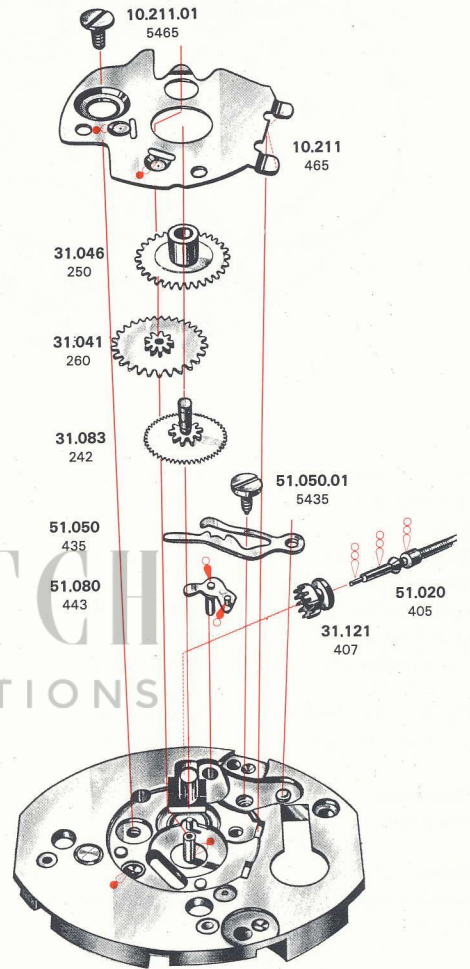

10.020.07  
100

Ref. 编号	Liste des fournitures	List of materials	Bestandteile	零件 名称
10.020.07	100	Platine	Werkplatte	主夹板
10.048.07	110	Train wheel bridge	Räderwerkbrücke	系列夹板
10.211	465	Couvre-rouage de mise à l'heure	Deckplatte für Zeigerwerk	手动过轮系板
10.300	144	Fixateur de cadran	Zifferblatthalter	表盘固定器
10.513	4000	Module électronique	Elektronik-Baugruppe	电子表机芯
20.570	4929	Batterie	Batterie	电池
20.580	4211	Rotor	Rotor	转子
20.582	4021	Stator	Stator	定子
20.590	4060	Bobine	Spule	线圈
20.651	4046	Isolateur de pile	Battery insulator	电池绝缘体
20.761	4401	Bride +	Bügel +	限动杆
20.920	4068	Protection de bobine	Coil guard	线圈保护片
30.012	203	Roue intermédiaire	Zwischenrad	中间轮
30.025	210	Roue moyenne	Kleinbodenrad	三轮
30.027	227	Roue de seconde	Sekundenrad	二轮
31.041	260	Roue de minuterie	Wechselrad	时轮
31.046	250	Roue des heures	Stundenrad	分轮部份
31.083	242	Chaussée avec entraîneur	Minutenrohr mit Mitnehmer	带动四轮
31.121	407	Pignon coulant	Kupplungstrieb	离合轮
51.020	405	Tige de mise à l'heure	Stellwelle	机芯止动杆
51.050	435	Bascule-ressort de pignon coulant	Kupplungstriebhebelfeder	离合杆
51.080	443	Tirrette	Winkelhebel	拉档杆
51.205	470	Plaquette de maintien du pignon coulant	Halteplatte für Kupplungstrieb	离合轮保护细片
56.071	560	Lévier d'arrêt de seconde au centre	Mittelsekunde-Abstellhebel	中心秒止动杆
80.210	4396	Entretoise de pont de rouage	Zwischenstück Räderwerkbrücke	轮系夹板组合

Ref. 编号	Liste des fournitures
10.048.01	5110
10.211.01	5465
10.513.01	54000
20.761.01	54401
20.920.01	54068
51.050.01	5435
51.205.01	5470
56.071.01	5560

Ref. 编号	Pierre de
70.002	603
70.003	604
70.010	605
70.011	606
70.012	612
70.100	-
70.101	-



5130 B

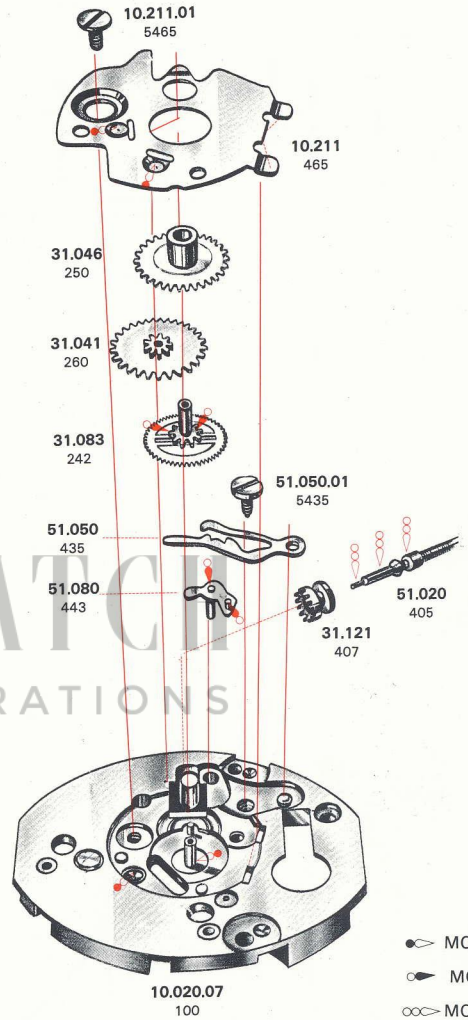
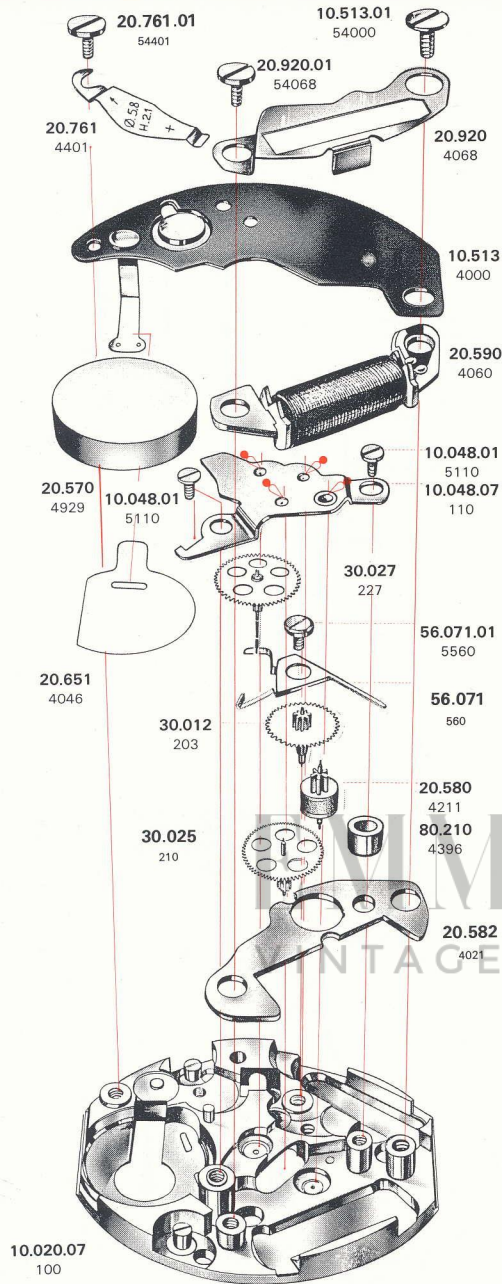

- MOEBIUS 9020
- MOEBIUS D 5
- MOEBIUS 8300

List of materials	Bestandteile	零件名称
Train wheel bridge screw	Raderwerkbrückenschraube	轮系夹板螺钉
Handsetting train cover screw	Zeigerwerkdeckplattenschraube	手车动过轮系板螺钉
Electronic module screw	Schraube der Elektronik-Baugruppe	电子附件螺钉
Bridle + screw	Schraube der Bügel +	托簧螺钉
Coil guard screw	Spulenschutzschraube	线圈保护片螺钉
Yoke-spring screw	Kupplungstriebhebel Feder Schraube	离合杆簧螺钉
Sliding pinion maintaining small plate screw	Schraube der Halteplatte für Kupplungstrieb	离合杆保护片细螺絲
Centre-second stop lever screw	Schraube der Mittelsekunden-Abstellhebel	秒针停杆螺絲

Fonctions de la tige Handsetting-stem functions Funktionen der Stellwelle 撥針杆的作用

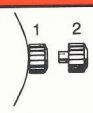

- 1 — marche normale
- 2 — mise à l'heure, stop-seconde avec interruption du courant pour le moteur
- 1 — regular running
- 2 — handsetting, stop-second with interruption of current to the motor
- 1 — normaler Gang
- 2 — Zeigerstellen, Sekunden-Stopp mit Unterbrechung der Motorspeisung
- 1 — 正常運轉
- 2 — 撥針、中止對電機的電流而停秒

Pile Batterie Batterie 電池

Ø 5,8 mm

1,55 V 2,1 mm

low drain

UCAR 379 RW 327  
RENATA 379  
VARTA 379 SR 521 SW

Jewel for:	Stein für:	宝石开子	mm 毫米
Intermediate wheel, top	Zwischenrad, oben	中間輪 上	15 × 90 × 22
Intermediate wheel, bottom	Zwischenrad, unten	中間輪 下	15 × 90 × 22
Third wheel, top	Kleinbodenrad, oben	三輪 上	15 × 90 × 22
Third wheel, bottom	Kleinbodenrad, unten	三輪 下	15 × 90 × 22
Second wheel, top	Sekundenrad, oben	秒輪 上	15 × 90 × 22
Rotor, top	Rotor, oben	轉子 上	12 × 90 × 22
Rotor, bottom	Rotor, unten	轉子 下	12 × 90 × 22