



France Ebauches 2031,2131,2731,2831 Movement Parts (1)

Compiled by EmmyWatch - <https://www.emmywatch.com>



francebauges

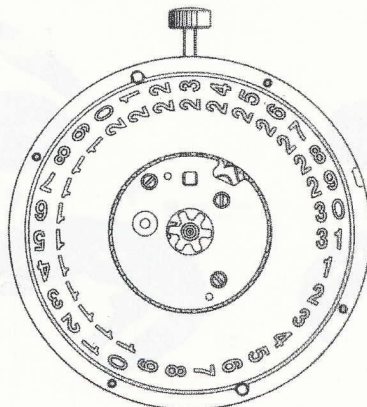
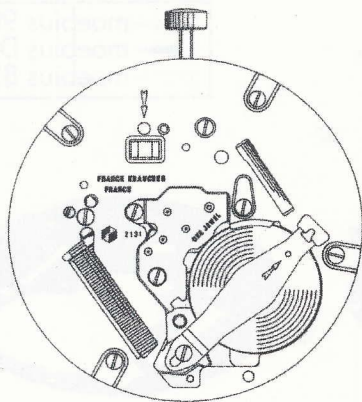

7 3/4 2721 2731

8 3/4 2821 2831

10 1/2 2021 2031



11 1/2 2121 2131

H = 2,65

			<i>DOSSIER TECHNIQUE</i>
7 3/4 *** Ø 17,2 mm	2721	2731	<i>TECHNICAL DOCUMENTATION</i>
8 3/4 *** Ø 19,4 mm	2821	2831	<i>TECHNISCHE DOKUMENTATION</i>
10 1/2 *** Ø 23,3 mm	2021	2031	技术文件
11 1/2 *** Ø 25,6 mm	2121	2131	

CARACTÉRISTIQUES TECHNIQUES	TECHNICAL DATA	TECHNISCHE DATEN	技术资料	mm 毫米			
Cage Diamètre total Diamètre encadrement	Frame Overall diameter Casing diameter	Gestell Gesamter Durchmesser Durchmesser zur Gehäusepassung	外壳 总直径 外壳直径	Cal. 2721 2731	Cal. 2821 2831	Cal. 2021 2031	Cal. 2121 2131
Hauteur sur filet Hauteur sur tige Hauteur maximum	Height at bead Height at stem Maximum height	Höhe am Wulst Höhe an der Welle Maximale Höhe	柄轴孔至表盘面高度 把芯高度 最大高度	17,500 17,200	20,000 19,400	23,900 23,300	26,200 25,600
Tige de mise à l'heure Diamètre du filetage	Handsetting stem Threading diameter	Stellwelle Gewindedurchmesser	止动杆 把芯螺纹直径			0,900	
Résonateur Fréquence	Resonator Frequency	Resonator Frequenz	谐振器 振荡			32.768 Hz	
Moteur Nombre d'impulsions par minute	Motor Number of impulses p/ minute	Motor Impulszahl p/ Minute	马达 脉冲次数/分			60	
Exécution : 1 rubis	Version : 1 jewel	Ausführung : 1 Stein	型式 : 粘				

CARACTÉRISTIQUES TECHNIQUES - TECH

-  moebius 9020
-  moebius D5
-  moebius 8200



7 3/4
2721
2731

8 3/4
2821
2831

10 1/2
2021
2031

11 1/2
2121
2131



Réf.	Liste des fournitures	List of materials	Bestandteile	零件名称	
10.020.07	100	Platine	Main plate	Werkplatte	主夹板
10.048.07	110	Pont de rouage	Train wheel bridge	Räderwerkbrücke	小夹板
10.060	136	Potence de tige	Setting Stem bridge	Brücke für Zeigerstellwelle	中夹板
10.513	4000	Module électronique	Electronic module	Elektronik-Baugruppe	线路板
10.601	4412	Plaque de limitation de pile	Battery limiting plate	Begrenzungsplatte für Batterie	电池限位板
13.100	2740	Plaque de maintien du mécanisme de quantième	Date mechanism maintaining plate	Halteplatte für Datum-Mechanismus	日历机构盖板
20.570	4929	Pile	Battery	Batterie	电池
20.580	4211	Rotor	Rotor	Rotor	转子
20.582	4021	Stator	Stator	Stator	定子
20.590	4060	Bobine	Coil	Spule	线圈
20.651	4046	Isolateur de pile	Battery insulator	Isolation für Batterie	电池绝缘片
20.761	4401	Bride +	Bridge +	Bügel +	限动杆
30.012	203	Roue intermédiaire	Intermediate wheel	Zwischenrad	中间轮
30.025	210	Roue moyenne	Third wheel	Kleinbodenrad	三轮
30.027	227	Roue de seconde	Second wheel	Sekundenrad	二轮
31.041	260	Roue de minuterie	Minute wheel	Wechselrad	分轮
31.083	242	Chaussée avec entraîneur	Cannon pinion with driver	Minutenrohr mit Mitnehmer	带齿齿轮
31.100	450	Renvoi	Setting wheel	Zeigerstellrad	拨针轮
31.121	407	Pignon coulant	Sliding pinion	Kupplungstrieb	离合轮
33.010	2558	Roue des heures double denture	Double-toothed hour wheel	Stundenrad mit Doppelverzahnung	双齿时轮
33.020	2556	Roue entraîneuse de l'indicateur de quantième	Date indicator driving wheel	Datumanzeiger-Mitnehmerrad	日历指示盘带动轮
51.020	405	Tige de mise à l'heure	Handsetting stem	Stellwelle	机芯止动杆
51.050	435	Bascule de pignon coulant	Yoke	Kupplungtriebhebel	离合杆
51.080	443	Tirette	Setting lever	Winkelhebel	拉档压
51.090	445	Sautoir de tirette	Setting lever jumper	Winkelhebelraste	拉档压簧
53.080	2576	Sautoir de quantième	Date jumper	Datummaste	日历定位
80.210	4396	Entretoise de pont de rouage	Train wheel bridge banking	Zwischenstück Räderwerkbrücke	小夹板限位装置
91.440	2557/1	Indicateur de quantième	Date indicator	Datumanzeiger	日历指示盘
10.048.01	5110	Vis de pont de rouage (FE42)	Train wheel bridge screw (FE42)	Schraube für Räderwerkbrücke (FE42)	小夹板螺丝 (FE 42)
10.513.01	54000	Vis de module électronique (FE77)	Electronic module screw (FE77)	Schraube für Elektronik-Baugruppe (FE77)	线路板螺丝 (FE 77)
10.601.01	54412	Vis de plaque de limitation de pile (FE63)	Battery limiting plate screw (FE63)	Schraube für Begrenzungsplatte für Batterie (FE 63)	电池限位板螺丝 (FE 63)
10.601.02	54412/1	Vis de plaque de limitation de pile (FE42)	Battery limiting plate screw (FE42)	Schraube für Begrenzungsplatte für Batterie (FE 42)	电池限位板螺丝 (FE 42)
13.100.01	52740	Vis de plaque de maintien du mécanisme de quantième (FE65)	Date mechanism maintaining plate screw (FE65)	Schraube für Halteplatte für Datum-Mechanismus (FE65)	电池限位板螺丝 (FE 65)
20.761.01	54401	Vis de bride + (FE64)	Bridge + screw (FE64)	Schraube für Bügel + (FE64)	限动杆螺丝 (FE 64)
51.090.01	5445	Vis de sautoir de tirette (FE42)	Setting lever jumper screw (FE42)	Schraube für Winkelhebelraste (FE42)	拉档压簧螺丝 (FE 42)

CADRAN - DIAL - ZIFFERBLATT - 表盘

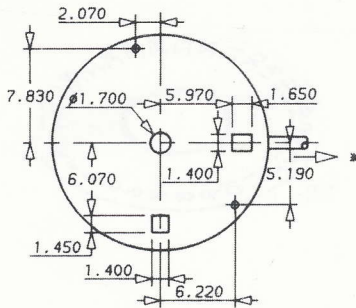

CAL 2721 - 2731
7 3/4

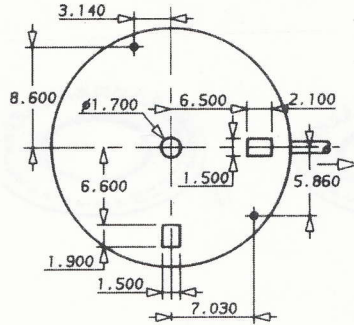

CAL 2821 - 2831
8 3/4

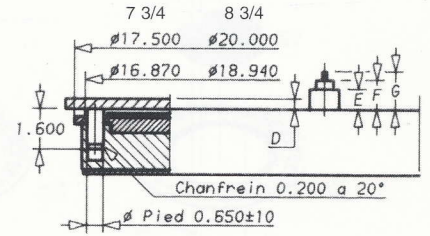

* COURSE DE LA TIGE : 0,800
STEM TRAVELLING
WEG DER STELLWELLE
拔杆運行山

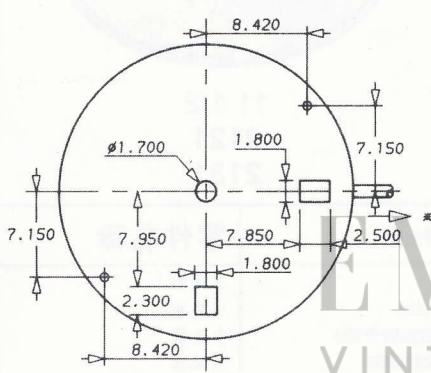

CAL 2021 - 2031
10 1/2

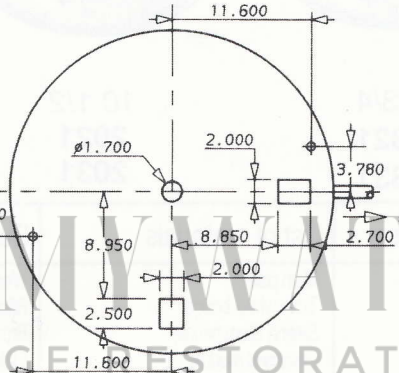

CAL 2121 - 2131
11 1/2

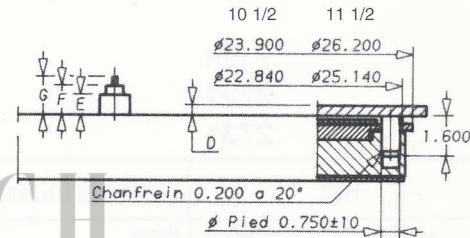

AIGUILLAGE - HANDFITTING - ZEIGERSETZEN - 表针装配

Effort de chassage : 20 newtons
Driving in pressure : 20 newtons
Einpressdruck : 20 newtons
钻入压力 : 20 牛顿

Seconde
Second
Sekunde
秒

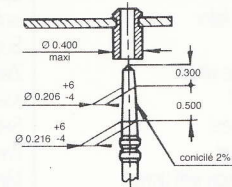

Roue des heures
Hour wheel
Stundenrad
时轮

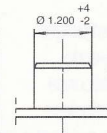

Chaussée
Cannon pinion
Minutenrohr
齿轮

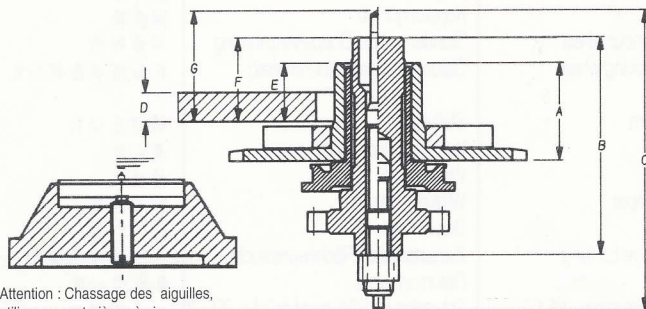
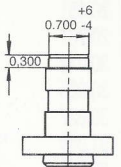

Attention : Chassage des aiguilles, utiliser un port-pièces à vis
Notice : for driving in of hands use movement holder with screw
Achtung : zum Einpressen von Zeigern verwenden sie einen Werkhalter mit Stuetzschraube

Aiguilles
Hands

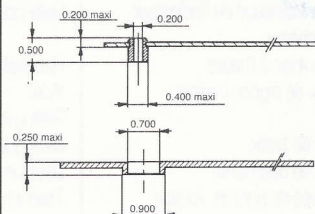

Zeiger
表针

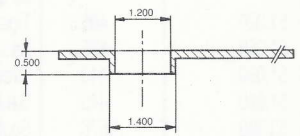

- | | | | |
|---|---|--|-------------------|
| 1 - marche normale | 1 - regular running | 1 - normaler Gang | 1 - 正常运转 |
| 2a - correction de la date | 2a - date correction | 2a - Datumkorrektur | 2a - 日历拨准 |
| 3 - mise à l'heure, stop-seconde avec interruption du courant pour le moteur. | 3 - handsetting, stop-second with interruption of current to the motor. | 3 - Zeigerstellen, Sekunden-Stopp mit Unterbrechung der Motorspeisung. | 3 - 拨针中止对电机的电流而止秒 |

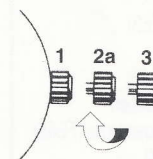

Fonctions de la tige
Handsetting - stem functions
Funktionen der Stellwelle
拔杆的作用

N°	CAL	AIGUILLAGE ZEIGERSETZEN HAND-FITTING 表针装配	A	B	C	D	E	F	G
1	2721-2821-2021-2121	Normal - 正常	1,390	3,050	2,180	0,400	0,800	1,200	--
3	2721-2821-2021-2121	Bas - Low - Niedrige - 低	1,240	2,850	2,180	0,300	0,650	1,000	--
4	2721-2821-2021-2121	Haut - Hi 正常 Höhe -	1,890	3,550	2,180	-	1,300	1,700	-
1	2731-2831-2031-2131	Normal -	1,390	3,000	4,150	0,400	0,800	1,150	1,500
3	2731-2831-2031-2131	Bas - Low - Niedrige - 低	1,240	2,800	3,900	0,300	0,650	0,950	1,250
4	2731-2831-2031-2131	Haut - High - Höhe - 高	1,890	3,500	4,650	-	1,300	1,650	2,000
5	2731-2831-2031-2131	Haut - High - Höhe - 高	2,140	3,750	4,900	-	1,550	1,900	2,250

BOÎTES - CASING - EINSCHALEN - 表壳

CAL	CAL	CAL	CAL
2721	2821	2021	2121
2731	2831	2031	2131
7 3/4	8 3/4	10 1/2	11 1/2

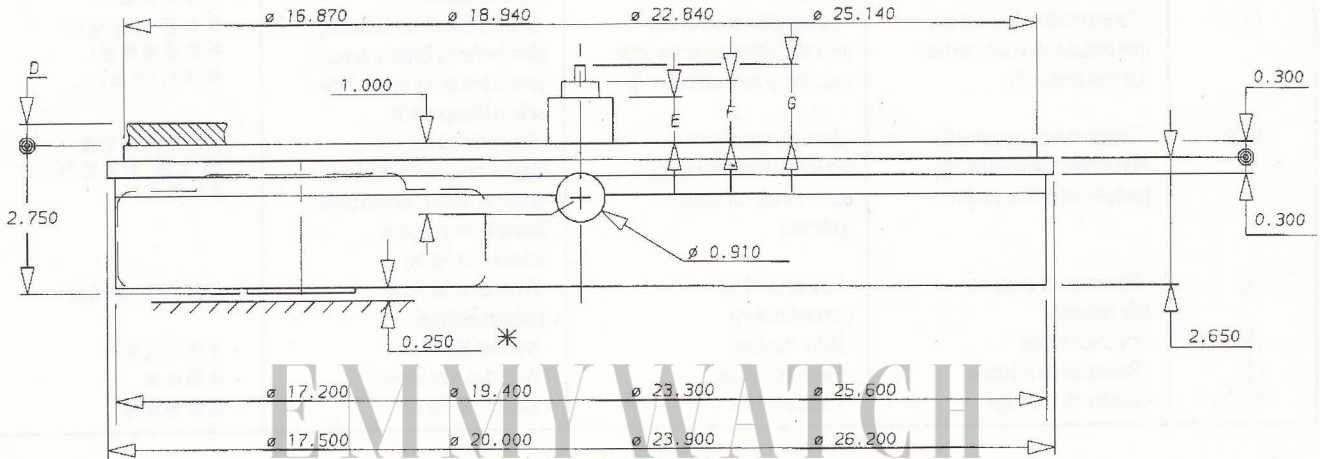

* OPTION CONTACT LATÉRAL (SANS BRIDE+)
HAUTEUR TOTALE 2.650.
LE MAINTIEN DE LA PILE DOIT ÊTRE ASSURÉ
PAR LE FOND (SÉCURITÉ MAXI 0.250)

* WITH LATERAL CONTACT (NO BRIDGE+)
TOTAL HEIGHT 2.650.
THE BATTERY MUST BE LOCKED UP FROM
THE BACK SIDE (MAXIMUM PLAY 0.250)

* MIT SEITLICHEM KONTAKT (OHNE BÜGEL+)
GESAMTE HÖHE 2.650.
DIE BATTERIE WIRD VON UNTEN GEHALTEN
(MAXIMALE LUFT 0.250)

* 侧面接触 (无正极片)
总高度 2.650
电池必须从后面固定
(最大空隙为 0.250)

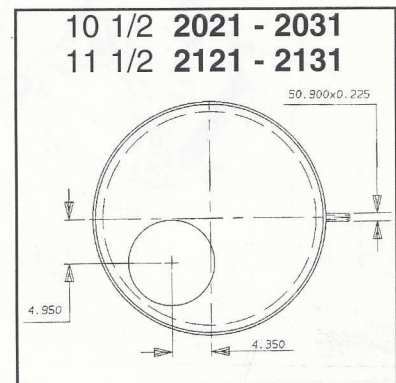
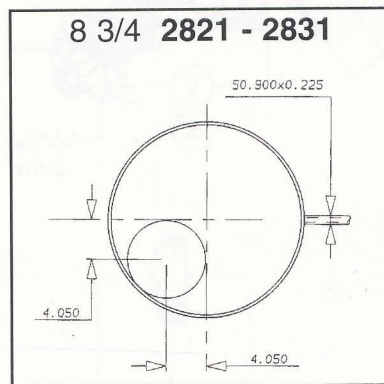
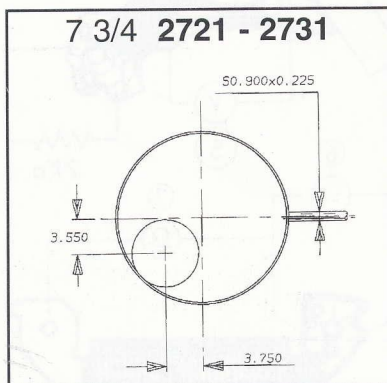

Pile - Battery - Batterie - 电池

CAL
2721
2731

RENATA 364
UCAR 364
VARTA V364
RW 364
SR 621 SW
IEC SR 60

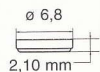

CAL
2821
2831

RENATA 362
UCAR 362
VARTA V362
RW 362
SR 721 SW
IEC SR 58

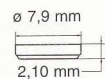

CAL
2021
2031
2121
2131

RENATA 371
UCAR 371
VARTA 371
RW 371
SR 920 SW
IEC SR 69

