



## Citizen C480 Movement Parts (1)

*Compiled by EmmyWatch - <https://www.emmywatch.com>*

# *TECHNICAL INFORMATION*

---

**CITIZEN QUARTZ**  
**Cal. No. C480**  
EMMYWATCH  
VINTAGE RESTORATIONS



EMMYWATCH  
VINTAGE RESTORATIONS

## ■1. OUTLINE

This caliber is a standard combination watch for men.

## ■2. SPECIFICATIONS

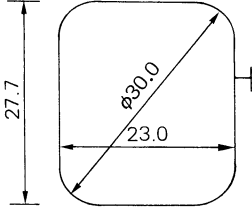
Cal. No.	C480A-00	
Type	Combination watch (Analog section: with center second)	
Movement (mm)		Thickness: 3.5 (measured when the power cell section is included)
Accuracy	±30 sec./month at normal temperatures	
Oscillation	32,768Hz	
Display method	FE twist-type nematic LC (Liquid Crystal)	
Integrated circuit	C/MOS-LSI (1 unit)	
Effective temp. range	0°C ~ +55°C (32°F ~ 131°F)	
Converter	Bipolar step motor	
Adjustment of time rate	Tip condenser (Without adjustment terminal)	
Measurement of time rate	2 seconds	
Display functions	Analog section	Hour, minute, second
	Digital section	
	Normal time	Hour, minute, second, AM/PM (12H/24H switching system)
	Calendar	Month, date, day
	Alarm	Hour, minute, AM/PM
	Stopwatch	Minute, second, 1/100 second (Up to 60 minutes timing)
Additional functions	<ul style="list-style-type: none"> <li>● Chime</li> <li>● Fully automatic calendar (February ends on the 28th)</li> <li>● Sound monitor</li> <li>● Lamp</li> </ul>	
Power cell	Parts No.	280-44
	Cell code	SR927W
	Size (mm)	9.5φ x 2.7t
	Voltage	1.5V
	Capacity	55mAH
	Lifetime	About 2.0 years (Alarm: 20 sec./day, Chime: 24 times/day).
Value of current	1.95μA (for the operation of the module)	

## 3. HANDLING INSTRUCTIONS

### 3-1. Nomenclature



- Crown ----- Setting of analog time
- (M) button ----- Mode changing, previous condition restoration
- (S) button ----- Selection of digits to be corrected, split, resetting
- (R) button ----- Light, correction, start, stop, ON/OFF of alarm

### 3-2. Mode switching procedure

The "☀" mark indicates flashing.

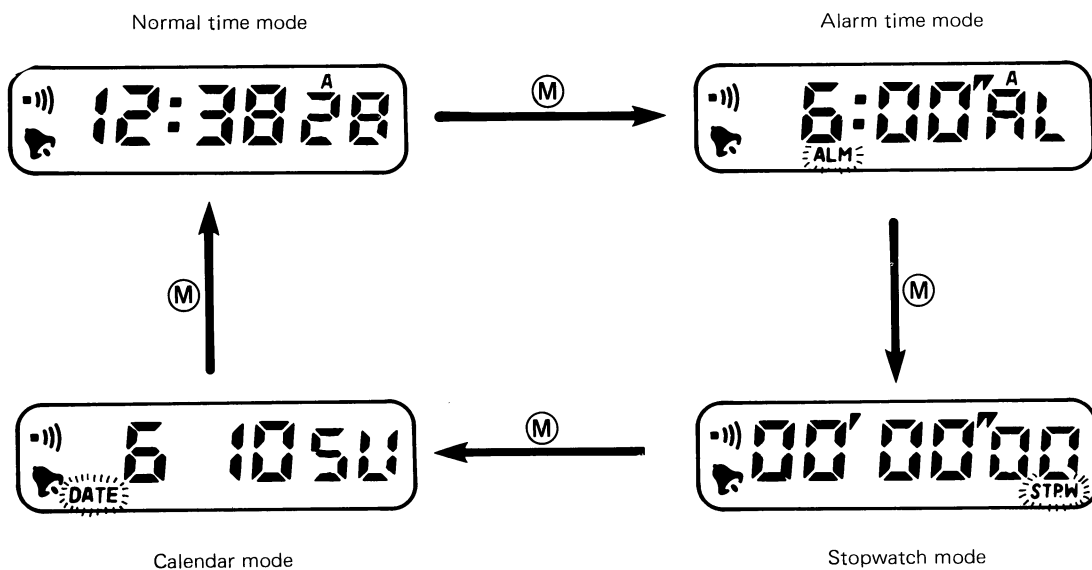

### 3-3. Correction procedure

#### (1) Correction of analog time

If the crown is pulled out to its first clicking position, the hands stop running. Then, set time by turning the crown either clockwise or counterclockwise.

When the crown is pushed back into its normal position, the second hand, synchronized with the second timing of the digital section, starts running.

#### (2) Correction of digital time

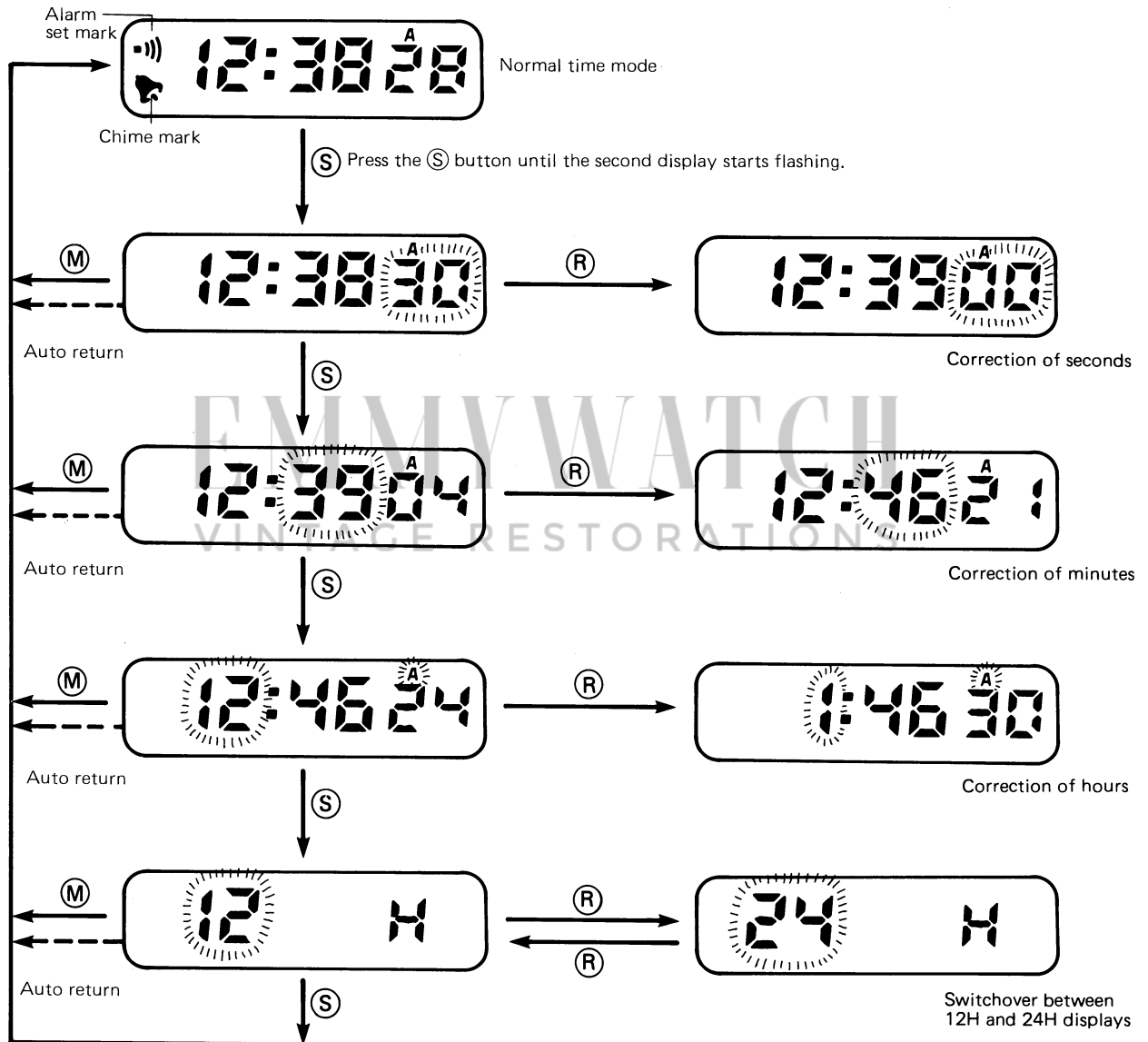

- While flashing, if **(R)** button is pressed and held, the number is advanced quickly (Quick advance).
- If any correction mode is left as it is for approximately one minute, the normal time display will automatically return. (Auto return)
- If correction of seconds is made between 00 and 29 on display, the second display will be corrected to "00".
- If it is made between 30 and 59 on display, the minute display will increase by one minute.
- If the **(M)** button is pushed after correction, the normal time display will be returned to normal time mode. (Manual return)
- Marks of A (AM) and P (PM) light up only in the 12-hour system.

## (3) Correction of alarm time

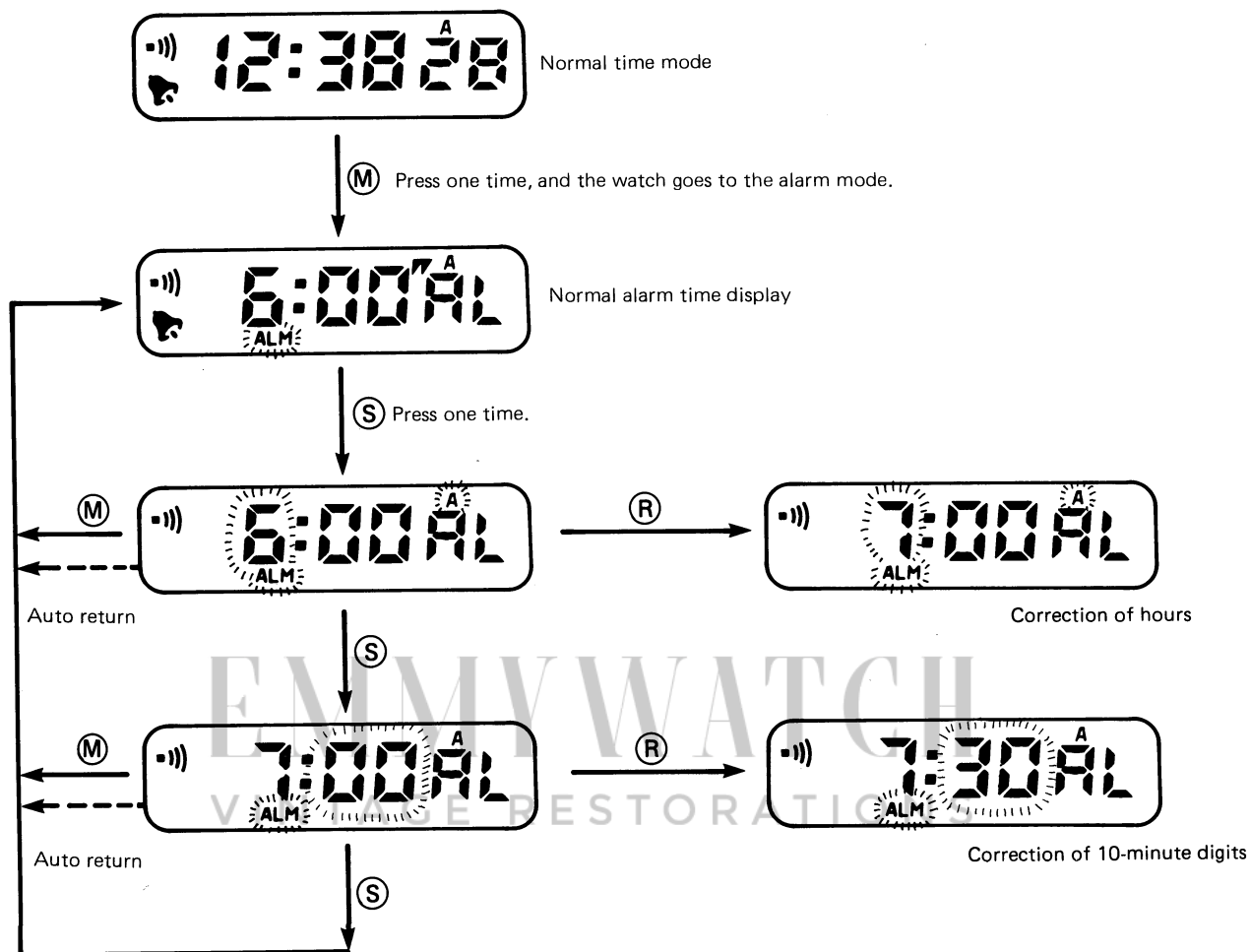

- "Hour" of alarm time is set in accordance with the 12H/24H of the normal time mode.
- If any correction mode is left as it is for approximately one minute, the alarm display will automatically return. (Auto return)
- If the (M) button is pushed after correction, the alarm display will be returned to normal alarm time display. (Manual return)
- If the (R) button is pressed and held in the correction mode (while the digit is flashing), the digit is advanced quickly. (Quick advance)

● Alarm setting and release

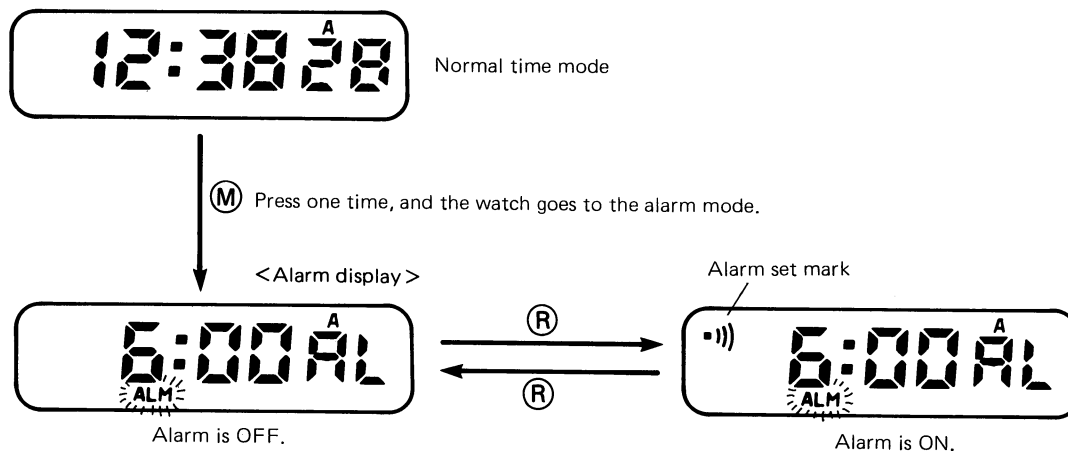

- Alarm sounds for 20 seconds.
- Alarm stops sounding with a push of any button with the exception of the crown.

● Setting and release of hourly chime, alarm monitor

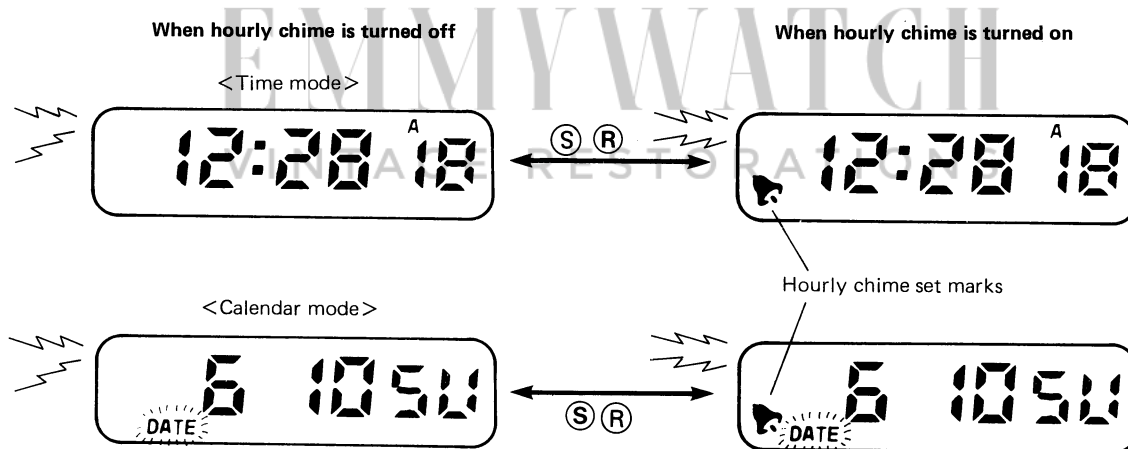

- The sound monitor is generated with a simultaneous push of the (S) and (R) buttons in the normal time mode or the calendar mode. At this moment, setting and release of hourly chime can be alternately carried out with every push of the (S) and (R) buttons at the same time.



## (4) Stop watch operation procedure

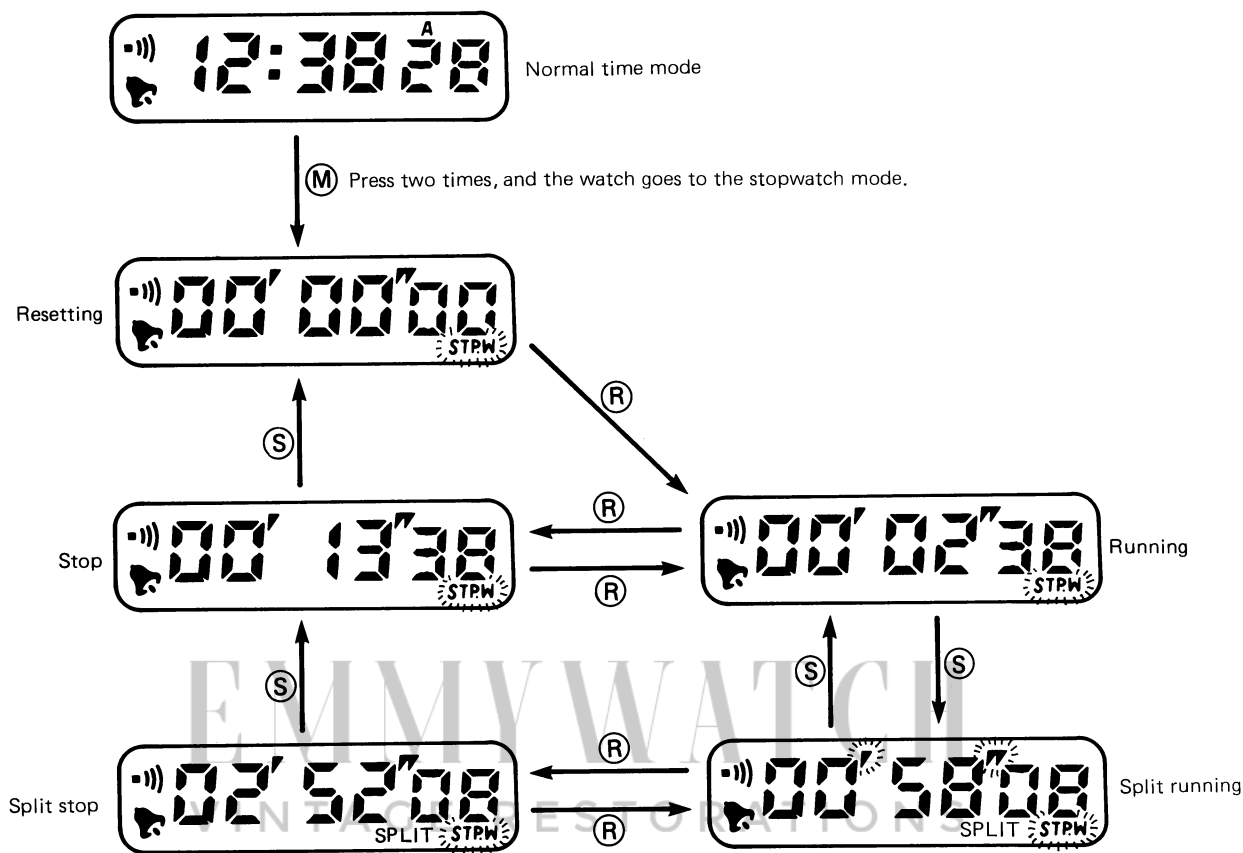

- Confirmation sound is heard with every push of either the (S) button or the (R) button.
- Timing will continue even if other modes are displayed during running.
- If other modes are displayed during the split running, normal running will replace the split running.
- In the stopwatch mode, if either the (S) button or the (R) button is pushed to stop the alarm which sounds during timing, the timing is also discontinued.
- If other modes are displayed during the split stop and then the stopwatch mode is displayed again, split stop time will be indicated.
- The stopwatch is a 60-minute stopwatch, that is, it can measure up to 59 minutes, 59 seconds, 99. After 59 minutes, 59 seconds, 99, the measurement is repeated from 00 minute, 00 second, 00.
- If the watch is changed from the split run state to another mode and then to the stopwatch mode again, it is set to the run state.

(5) Correction of calendar

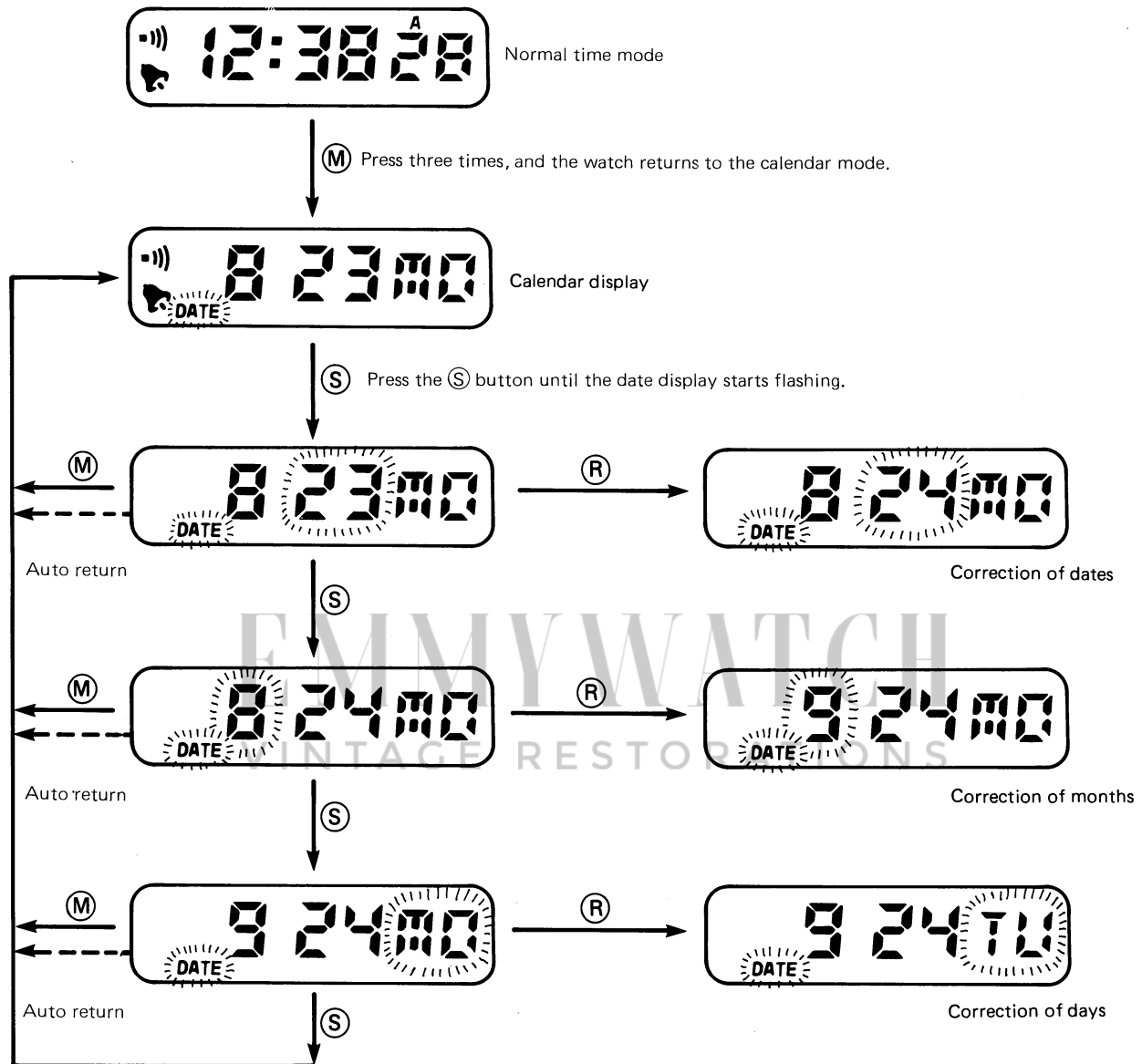

- If any correction mode is left as it is for approximately one minute, the calendar display will automatically return. (Manual return)
- If the (M) button is pushed after correction, the calendar display will be restored.
- If the non-existing date is set, the first day of the following month will be displayed when the calendar display returns or is restored. (Ex. FEB. 30th → MAR. 1st)
- In this watch, February ends on the 28th. Date correction is necessary during a leap year.
- If the (B) button is pressed and held in the correction mode, the digit is advanced quickly. (Quick advance)
- If the watch is kept in the correction mode for about 1 minute, the watch automatically returns to the normal calendar mode. (Auto return)

## 4. DISASSEMBLY AND ASSEMBLY OF MODULE

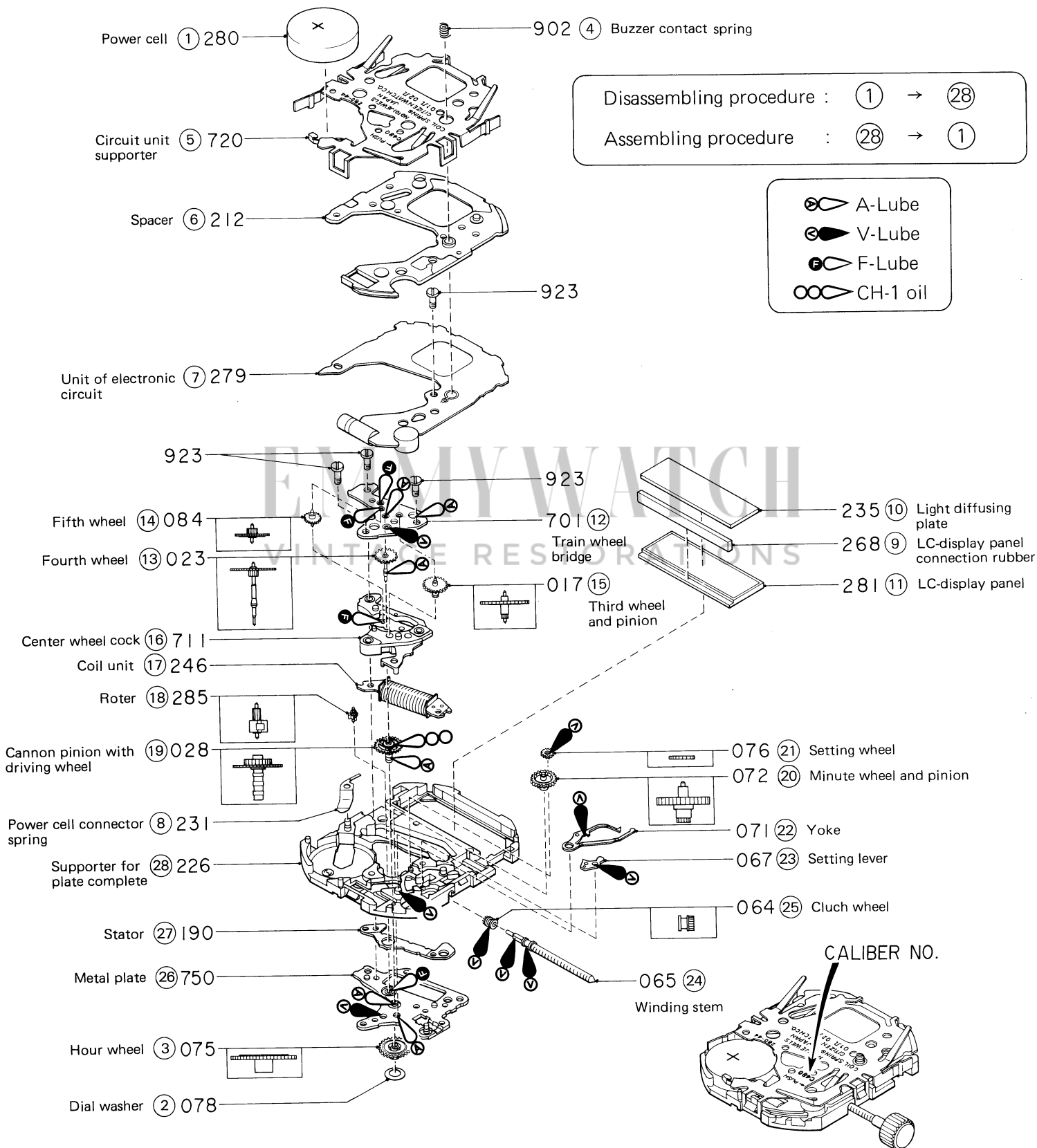

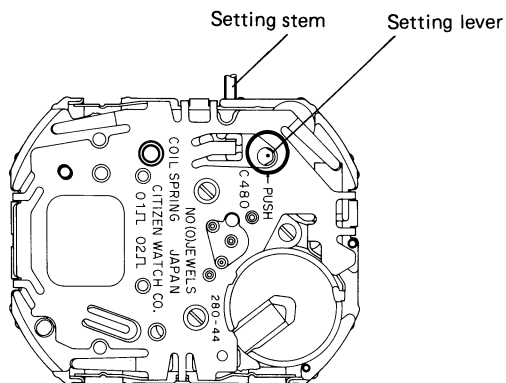
**5. NOTES ON DISASSEMBLY AND ASSEMBLY****(1) How to remove the setting stem**

Remove the setting stem while pushing the setting lever at the site indicated by the arrow using a fine instrument like tweezers, etc. The above procedure should be carried out with the setting stem remaining in its normal position.

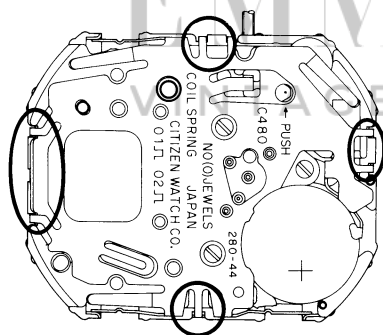
**(2) Mounting of the supporter for plate complete**

When mounting the supporter for plate complete, make sure that three points of the supporter for plate complete which are circled in the diagram have been placed within the LC display panel supporter.

■6. TROUBLESHOOTING AND ADJUSTMENT

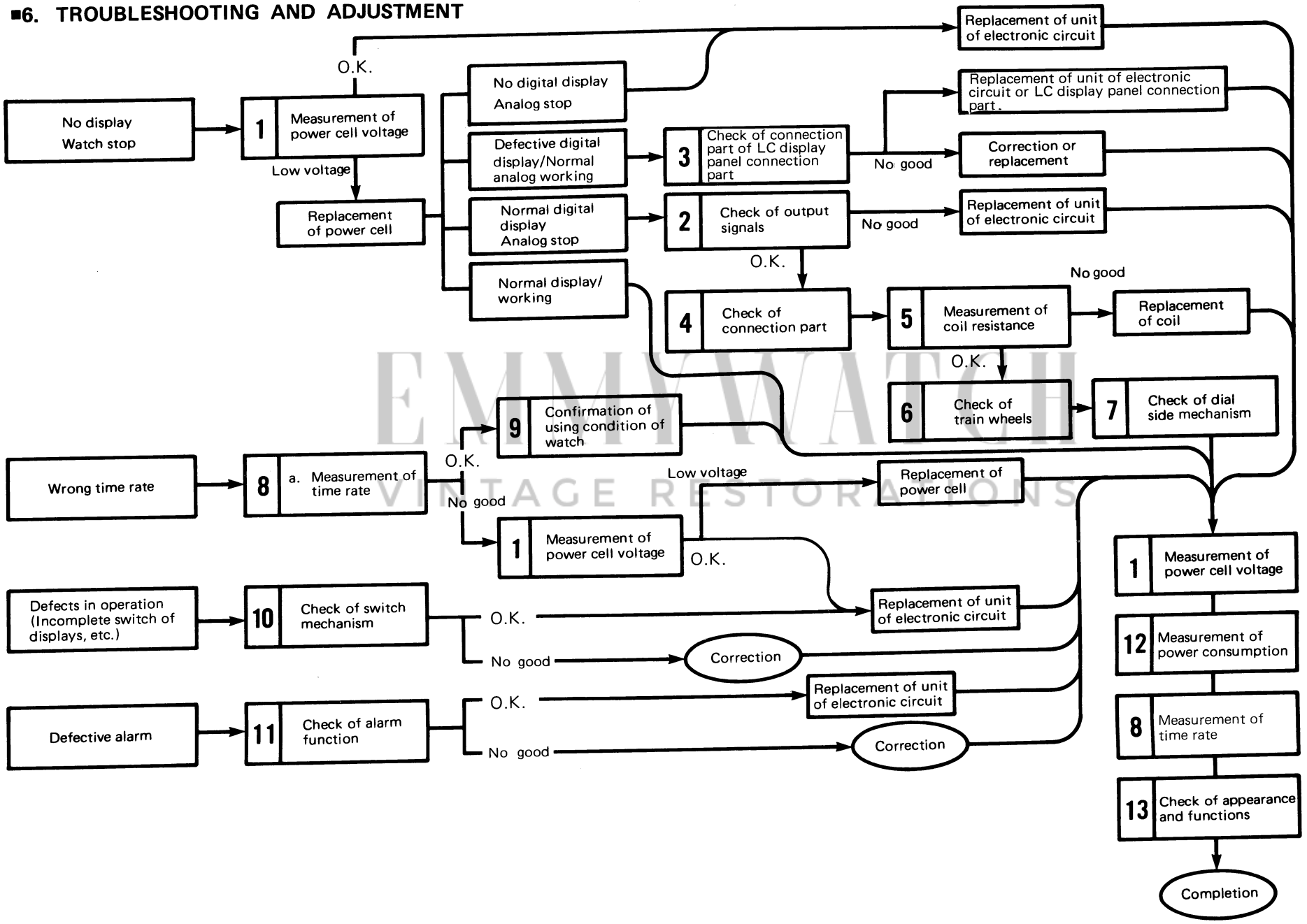

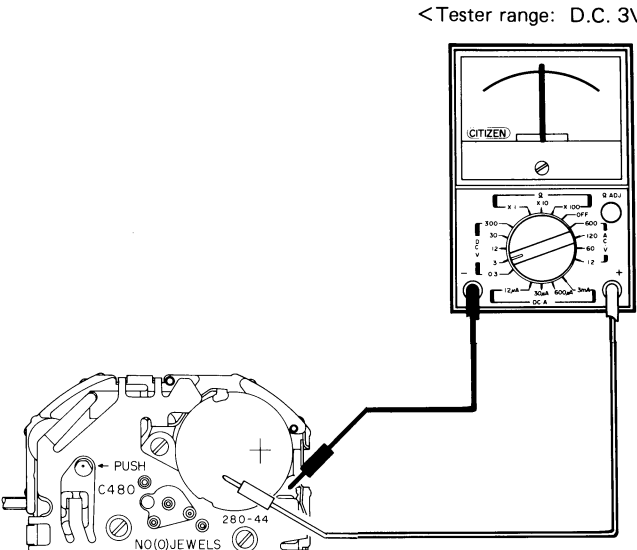
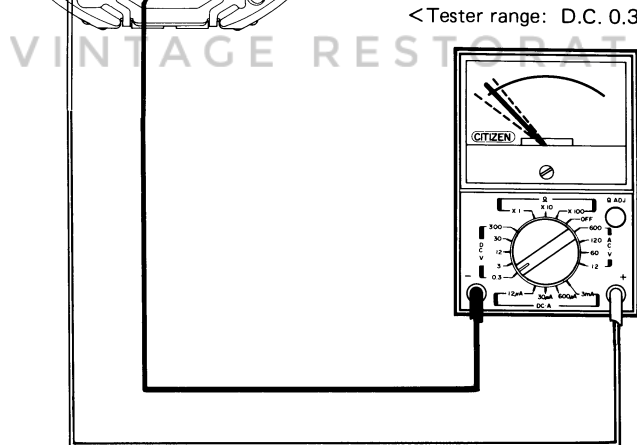
Checking items	How to check	Result and treatment
<p><b>1</b> Measurement of power cell voltage</p>	<p>[Refer to Technical Manual, Basic Course: II-1 Measuring Power Cell Voltage]</p> <p style="text-align: center;">&lt;Tester range: D.C. 3V &gt;</p> 	<p><b>Over 1.5V</b> → Nondefective</p> <p><b>Under 1.5V</b> → Replace the power cell</p>
<p><b>2</b> Confirmation of output signal</p>	<p style="text-align: center;">&lt;Tester range: D.C. 0.3V &gt;</p>  <p>[Refer to Technical Manual, Basic Course: II-1 Confirming Out Put Signal]</p>	<p>If the tester pointer swings back and forth around zero every second, the unit of electronic circuit is nondefective.</p>
<p><b>3</b> Checking LC display panel connection parts</p>	<p>Check the following points;</p> <ul style="list-style-type: none"> <li>● Whether the LC display panel connection rubber has been properly mounted.</li> <li>● Whether the LC display panel connection rubber has not been damaged.</li> <li>● Whether there is no dust or dirt on the connection parts.</li> </ul>	<ul style="list-style-type: none"> <li>● If mounting was incorrect, mount again.</li> <li>● If it has been damaged, replace it with a new one.</li> <li>● If dust or dirt is found, remove it.</li> </ul>

Checking items	How to check	Result and treatment
<b>4</b> Checking connection between unit of electronic circuit and coil unit	<ul style="list-style-type: none"> <li>●Check that there is no dust or dirt on the connection parts.</li> <li>●Check that the screws have been fastened.</li> </ul>	<ul style="list-style-type: none"> <li>●If dust or dirt is found, remove it.</li> <li>●If the screws are loose, fasten them.</li> </ul>
<b>5</b> Measurement of coil resistance	<p>[Refer to Technical Manual, Basic Course: II-1 Measuring Coil Resistance]</p>	<p>Within a range of <b>2.0KΩ ~ 2.4KΩ</b>            → Nondefective</p> <p>Beyond the above range            → Replace the coil unit.</p>
<b>6</b> Checking train wheel	<p>[Refer to Technical Manual, Basic Course: II-2-b Checking Train Wheel]</p> <p>Check the following points;</p> <ul style="list-style-type: none"> <li>●Whether the transmission goes smoothly with each gear with an appropriate clearance and with no backlash.</li> <li>●Whether no foreign matter gets in the gears.</li> <li>●Whether lubrication is in a good condition.</li> <li>●Whether hole jewels have no cracks or cuts.</li> </ul>	<ul style="list-style-type: none"> <li>●If improper clearance or backlash is found, adjust the gear.</li> <li>●Foreign matter → Remove it.</li> <li>●Bad lubrication → Adjust it.</li> <li>●Cracks or cuts → Replace the hole jewels.</li> </ul>
<b>7</b> Checking dial – side mechanism	<p>[Refer to Technical Manual, Basic Course: II-2-c Checking Dial Side Mechanism]</p> <ul style="list-style-type: none"> <li>●Check that the hands go around in a correct way.</li> <li>●Check that the crown is pulled out in a correct way.</li> <li>●Check that each part has been properly mounted.</li> </ul>	<ul style="list-style-type: none"> <li>●There are problems with turning of the hands → Replace the parts or adjust them.</li> <li>●Pulling out the crown cannot be correctly performed → Replace the parts or adjust them.</li> <li>●Bad mounting → Mount again.</li> </ul>

EMMYWATCH  
VINTAGE RESTORATIONS

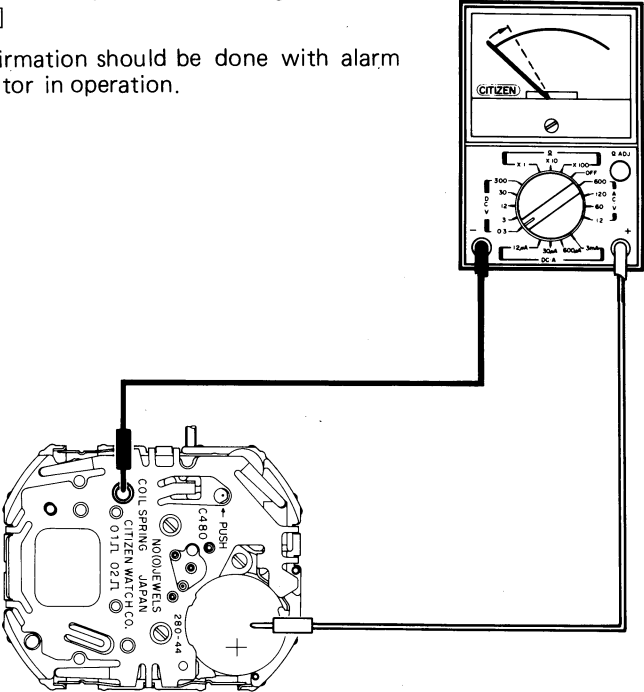
Checking items	How to check	Result and treatment
<b>8</b> Measurement of time rate	<p>[Refer to Technical Manual, Basic Course: II-2-d Measuring and Adjusting Time Rate]</p> <ul style="list-style-type: none"> <li>● Measurement of time rate. Measurement is possible with either of CQT-101 and CQT-210.</li> </ul>	<ul style="list-style-type: none"> <li>● The watch loses or gains substantial time → replace the electronic circuit unit.</li> </ul>
<b>9</b> Confirmation of using condition	<p>[Refer to Technical Manual, Basic Course: II-2-e Confirming Using Conditions]</p> <p>It is thought that accuracy is affected by the environments in which the watch is used.</p> <p>Therefore, confirm the using condition in terms of magnetism, temperature, humidity, shock, etc.</p>	
<b>10</b> Checking switch mechanism	<p>Check each switch spring in the following points,</p> <ul style="list-style-type: none"> <li>● Whether the switch spring has not been damaged.</li> <li>● Whether the switch spring is in a good contact with the push button.</li> <li>● Whether the switch spring is in a good contact with the pattern of the plate.</li> <li>● Whether dust or dirt around the push buttons creates bad operation of the push buttons.</li> </ul>	<ul style="list-style-type: none"> <li>● Damaged switch spring → Replace it.</li> <li>● Bad contact → Adjust it.</li> <li>● Bad contact → Adjust it.</li> <li>● Bad operation → Remove dust or dirt.</li> </ul>
<b>11</b> Checking alarm	<p>[Refer to Technical Manual, Basic Course: II-1 Confirming the Out Put Signal of the Alarm]</p> <p>Confirmation should be done with alarm monitor in operation.</p> <div style="text-align: center;">  </div>	<ul style="list-style-type: none"> <li>● The tester pointer swings. → Nondefective</li> <li>● The tester pointer does not swing at all. → Replace the plate complete.</li> </ul>

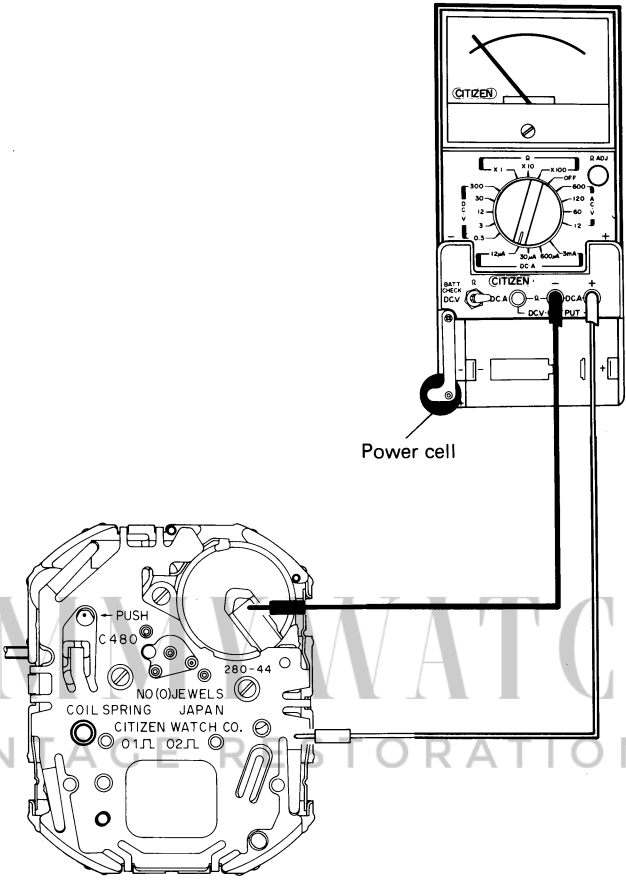

Checking items	How to check	Result and treatment
<p><b>12</b> Measurement of current consumption</p>	<p>[Refer to Technical Manual, Basic Course: II-1 Measuring Current Consumption]</p> <p>&lt;Tester range: D.C. 12<math>\mu</math>A or 30<math>\mu</math>A &gt;</p>  <div style="border: 1px solid black; padding: 5px; margin-top: 20px;"> <p><b>Influence of light;</b>  <b>Avoid measuring current consumption under an incandescent lamp or the direct rays of the sun, because it may cause the current value to increase.</b></p> </div>	<ul style="list-style-type: none"> <li>● Current consumption of the module</li> </ul> <p><b>Under 1.95<math>\mu</math>A</b>          → Nondefective</p> <p><b>Over 1.95<math>\mu</math>A</b>          → Measure the unit of electronic circuit singly for current.</p> <ul style="list-style-type: none"> <li>● Measurement of the separate electronic circuit.</li> </ul> <p><b>Under 1.0<math>\mu</math>A</b>          → Nondefective</p> <p><b>Over 1.0<math>\mu</math>A</b>          → Replace the unit of electronic circuit.</p>

Checking items	How to check	Result and treatment
<p>13 Checking appearance and functions</p>	<p>[Refer to Technical Manual, Basic Course: II-2-f Checking Appearance and Functions]</p>  <ul style="list-style-type: none"> <li>● Make sure that there is no dust or dirt inside the watch.</li> <li>● Make sure that each button functions correctly.</li> <li>● Make sure that all the segments have been provided.</li> <li>● Make sure that the alarm monitor operates in an expected manner.</li> </ul>	
<p>EMMYWATCH VINTAGE RESTORATIONS</p>		

EMMYWATCH  
VINTAGE RESTORATIONS