



**EMMYWATCH**  
VINTAGE RESTORATIONS

Citizen 8962 Movement Parts (1)

*Compiled by EmmyWatch - <https://www.emmywatch.com>*

Catalog No. 8962-1 ~ 8962-2

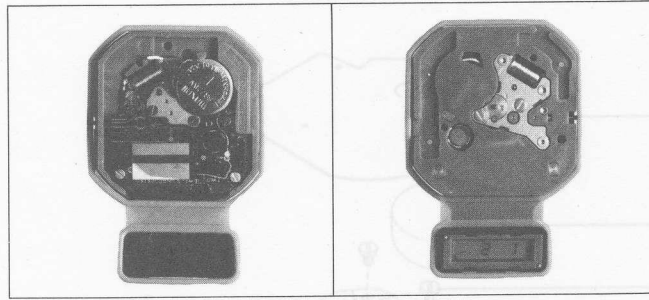

**8962-1**  
(Catalog No.)

**8962-2**  
(Catalog No.)

**8962**

- Quartz crystal oscillator type
- Analog display and LC digital display  
[ANALOG]
  - Hour/minute hands with 20-sec. step movement
  - Electromagnetic correction system
- [DIGITAL]
  - Time, Hour, Minute, Second
  - Calendar
  - Alarm
  - Chime function
  - Timer
  - 12/24-hour switching function

Thickness: Analog: 2.5mmt  
Digital: 2.1mmt

Size: Analog: 22.1 x 23.0 x 26.4φmm  
Digital: 14.86 x 6.16 mm

Vibrations per second

32,768Hz

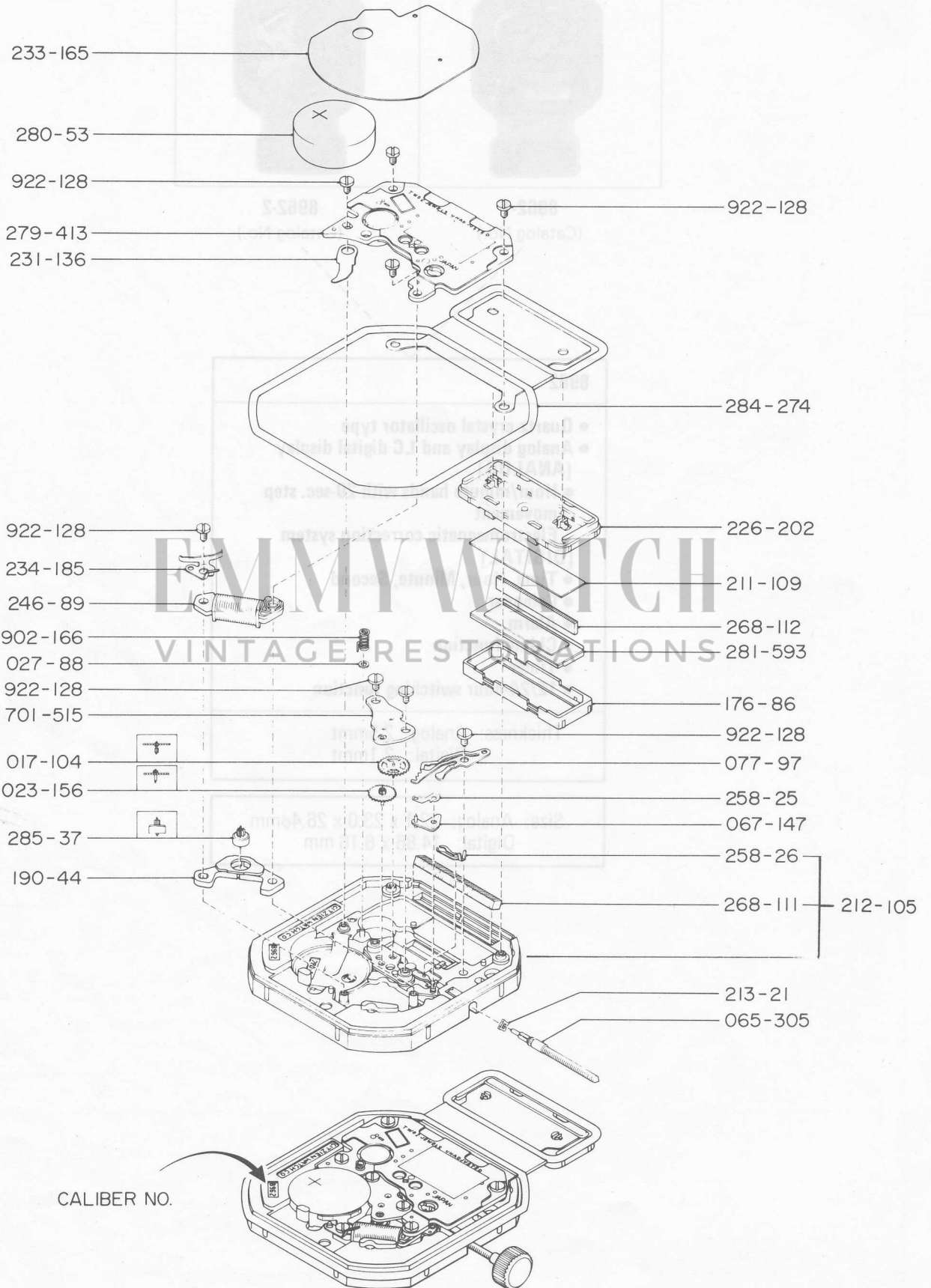

5-5888 32,768Hz  
Vibration per second

Catalog No. 8962-1

Parts No.	Caliber No.		8962												
	Name of parts	Nos. of jewels													
701	Train wheel bridge	515													
711	Center wheel cock	101													
017	Third wheel and pinion	104													
023	Fourth wheel and pinion	156													
027	Washer for buzzer contact spring	88													
065	Setting stem	296													
065	Setting stem (Long size)	305													
067	Setting lever	147													
077	Setting lever spring	97													
176	LC display panel holder	86													
190	Stator	44													
☆211	Reflecting plate (Gold)	107													
☆211	Reflecting plate (Silver)	109													
212	Composite spacer	105	(258-26 Already incorporated)												
213	Switch wheel	21													
226	LC display panel supporter	202													
231	Power cell connector spring	136													
233	Insulator sheet	165													
234	Power cell holder	185													
246	Coil unit	89													
258	Switch spring [I]	25													
258	Switch spring [II]	26													
268	Circuit connection rubber	111													
268	LC display panel connection rubber	112													
279	Unit of electronic circuit	413													
280	Power cell	53													
281	LC display panel	593													
284	Connection sheet	274													
285	Rotor	37													
902	Buzzer contact spring	166													
922	Screw for coil unit	128													
922	Screw for train wheel bridge	○													
922	Screw unit of electronic circuit	○													
922	Screw for setting lever spring	○													

☆For the reflecting plate, either one of the two types (silver and gold colors) is used.

